



website <http://www.lgservice.com>

LG

# LG Room Air Conditioner

## ***SERVICE MANUAL***

**MODELS: LA140CE**

### **CAUTION**

- BEFORE SERVICING THE UNIT, READ THE SAFETY PRECAUTIONS IN THIS MANUAL.
- ONLY FOR AUTHORIZED SERVICE PERSONNEL.

# TABLE OF CONTENTS

<b>LG Model Name</b> .....	3
<b>Safety Precautions</b> .....	4
<b>Dimensions</b> .....	8
Symbols used in this Manual.....	8
Indoor Unit.....	9
Outdoor Unit.....	9
<b>Product Specifications</b> .....	10
<b>Installation</b> .....	11
Select the Best Location .....	11
Piping Length and Elevation.....	11
Fixing Installation Plate .....	12
Drill a Hole in the wall.....	12
Flaring Work.....	13
Connecting the Piping .....	14
Connecting the Cables .....	19
Connection method of the connecting cable(Example).....	20
Connect the cable to the indoor unit.....	21
Checking the Drainage.....	22
Forming the Piping .....	23
Air Purging .....	24
Test Running .....	26
<b>Operation</b> .....	28
Function of Controls .....	28
Display Function.....	34
Self-diagnosis Function .....	34
Remote Control Operations.....	35
<b>Disassembly</b> .....	36
Indoor Unit.....	36
<b>Schematic Diagram</b> .....	39
Electric control Device.....	39
Wiring Diagram.....	41
Components Location .....	42
<b>Troubleshooting Guide</b> .....	46
Refrigeration Cycle Diagram .....	46
2-way, 3-way Valve .....	47
Cycle Parts.....	52
Electronic Parts .....	53
<b>Exploded View &amp; Replacement Parts List</b> .....	62
Indoor Unit.....	63
Outdoor Unit.....	64

# LG Model Name

2003

1	2	-	3	4	5	6	7	8	9	10
---	---	---	---	---	---	---	---	---	---	----

Code	Type	Code of Model	Meaning																																								
1	Producing Center, Refrigerant	A~Z	L: Chang-won R22 A: Chang-won R410A C: Chang-won R407C T: China K: Turkey R22 E: Turkey R410A H: Thailand N: India Z: Brazil D: Indonesia M: Mexico V: Vietnam S: Out Sourcing																																								
2	Product Type	A~Z	S: Split Type Air Conditioner																																								
3	Cooling/Heating/Inverter	A~Z	C: Cooling only H: Heat pump X: C/O + E/Heater Z: H/P + E/Heater V: AC Inverter C/O N: AC Inverter H/P Q: DC Inverter C/O W: DC Inverter H/P																																								
4, 5	Capacity	0~9	Cooling/Heating Capacity Ex. "09" → 9,000 Btu/h																																								
6	Electric Range	1~9 A~Z	1: 115V/60Hz, 2: 220V/60Hz 3: 208-230V/60Hz 5: 200-220V/50Hz 6: 220-240V/50Hz 7: 110V, 50/60Hz 8: 380-415V/50Hz 9: 380-415V/60Hz A: 220V, 50Hz, 3Phase B: 208~230V, 60Hz, 3Phase C: 575V, 50Hz, 3Phase D: 440~460, 60Hz, 3Phase E: 265V, 60Hz F: 200V, 50/60Hz																																								
7	Chassis	A~Z	Name of Chassis of Unit Ex. LSP → SP Chassis																																								
8	Look	A~Z	Look, Color (Artcool Model)																																								
9	Function	A~Z	<table border="1"> <tr><td>Basic</td><td>A</td></tr> <tr><td>Basic+4Way</td><td>B</td></tr> <tr><td>Plasma Filter</td><td>C</td></tr> <tr><td>Plasma Filter+4 Way</td><td>D</td></tr> <tr><td>Tele+LCD</td><td>E</td></tr> <tr><td>Tele+LCD+Nano plasma+4Way</td><td>F</td></tr> <tr><td>Nano Plasma F+(A/changeove)+A/clean+Low A</td><td>G</td></tr> <tr><td>Nano Plasma F+(A/changeove)+A/clean+4way+Low A</td><td>H</td></tr> <tr><td>Tele+LED+4way</td><td>I</td></tr> <tr><td>Internet</td><td>J</td></tr> <tr><td>Plasma F+4Way+Oxy generator</td><td>K</td></tr> <tr><td>Nano Plasma F+(A/changeove)+A/clean</td><td>L</td></tr> <tr><td>Nano Plasma F+(A/changeove)+A/clean+4way</td><td>M</td></tr> <tr><td>Nano Plasma F+(A/changeove)+A/clean+PTC</td><td>N</td></tr> <tr><td>Nano Plasma F+(A/changeove)+Autoclean+4way+PTC</td><td>P</td></tr> <tr><td>Nano Plasma F+(A/changeove)+A/clean+4way+Low A+PTC</td><td>Q</td></tr> <tr><td>Negative ION+A/Clean</td><td>R</td></tr> <tr><td>(Nano)Plasma+Negative ION+A/Clean</td><td>S</td></tr> <tr><td>4way+(Nano)Plasma F+Negative ION+Healthy dehumidification+A/Clean</td><td>T</td></tr> <tr><td>Nano Plasma F+4Way+(A/changeove)+A/clean+</td><td>U</td></tr> </table>	Basic	A	Basic+4Way	B	Plasma Filter	C	Plasma Filter+4 Way	D	Tele+LCD	E	Tele+LCD+Nano plasma+4Way	F	Nano Plasma F+(A/changeove)+A/clean+Low A	G	Nano Plasma F+(A/changeove)+A/clean+4way+Low A	H	Tele+LED+4way	I	Internet	J	Plasma F+4Way+Oxy generator	K	Nano Plasma F+(A/changeove)+A/clean	L	Nano Plasma F+(A/changeove)+A/clean+4way	M	Nano Plasma F+(A/changeove)+A/clean+PTC	N	Nano Plasma F+(A/changeove)+Autoclean+4way+PTC	P	Nano Plasma F+(A/changeove)+A/clean+4way+Low A+PTC	Q	Negative ION+A/Clean	R	(Nano)Plasma+Negative ION+A/Clean	S	4way+(Nano)Plasma F+Negative ION+Healthy dehumidification+A/Clean	T	Nano Plasma F+4Way+(A/changeove)+A/clean+	U
Basic	A																																										
Basic+4Way	B																																										
Plasma Filter	C																																										
Plasma Filter+4 Way	D																																										
Tele+LCD	E																																										
Tele+LCD+Nano plasma+4Way	F																																										
Nano Plasma F+(A/changeove)+A/clean+Low A	G																																										
Nano Plasma F+(A/changeove)+A/clean+4way+Low A	H																																										
Tele+LED+4way	I																																										
Internet	J																																										
Plasma F+4Way+Oxy generator	K																																										
Nano Plasma F+(A/changeove)+A/clean	L																																										
Nano Plasma F+(A/changeove)+A/clean+4way	M																																										
Nano Plasma F+(A/changeove)+A/clean+PTC	N																																										
Nano Plasma F+(A/changeove)+Autoclean+4way+PTC	P																																										
Nano Plasma F+(A/changeove)+A/clean+4way+Low A+PTC	Q																																										
Negative ION+A/Clean	R																																										
(Nano)Plasma+Negative ION+A/Clean	S																																										
4way+(Nano)Plasma F+Negative ION+Healthy dehumidification+A/Clean	T																																										
Nano Plasma F+4Way+(A/changeove)+A/clean+	U																																										
10	Serial No.	1~9	LG Model Development Serial No. * ARTCOOL COLOR <table border="1"> <tr><td>R</td><td>Mirror</td></tr> <tr><td>W</td><td>White</td></tr> <tr><td>B</td><td>Blue</td></tr> <tr><td>D</td><td>Wood</td></tr> <tr><td>M</td><td>Metal</td></tr> <tr><td>C</td><td>Cherry</td></tr> </table>	R	Mirror	W	White	B	Blue	D	Wood	M	Metal	C	Cherry																												
R	Mirror																																										
W	White																																										
B	Blue																																										
D	Wood																																										
M	Metal																																										
C	Cherry																																										

# Safety Precautions



To prevent injury to the user or other people and property damage, the following instructions must be followed.

■ Incorrect operation due to ignoring instruction will cause harm or damage. The seriousness is classified by the following indications.

**⚠ WARNING** This symbol indicates the possibility of death or serious injury.

**⚠ CAUTION** This symbol indicates the possibility of injury or damage to properties only.

■ Meanings of symbols used in this manual are as shown below.

	<b>Be sure not to do.</b>
	<b>Be sure to follow the instruction.</b>

## ⚠ WARNING

### ■ Installation

**Always perform grounding.**

- Otherwise, it may cause electrical shock.

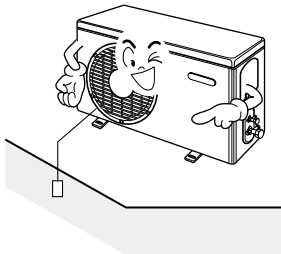

**Don't use a power cord, a plug or a loose socket which is damaged.**

- Otherwise, it may cause a fire or electrical shock.

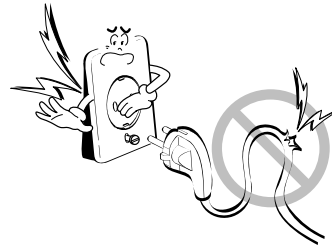

**For installation of the product, always contact the service center or a professional installation agency.**

- Otherwise, it may cause a fire, electrical shock, explosion or injury.

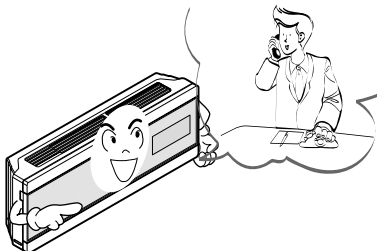

**Securely attach the electrical part cover to the indoor unit and the service panel to the outdoor unit.**

- If the electrical part cover of the indoor unit and the service panel of the outdoor unit are not attached securely, it could result in a fire or electric shock due to dust, water, etc.

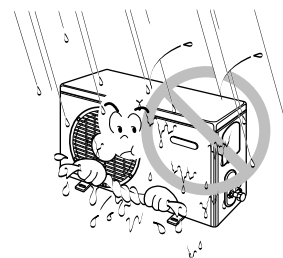

**Always install an air leakage breaker and a dedicated switching board.**

- No installation may cause a fire and electrical shock.

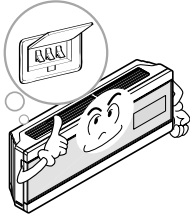

**Do not keep or use flammable gases or combustibles near the air conditioner.**

- Otherwise, it may cause a fire or the failure of product.

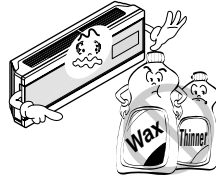

**Ensure that an installation frame of the outdoor unit is not damaged due to use for a long time.**

- It may cause injury or an accident.

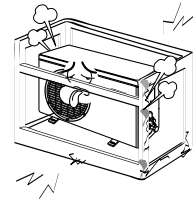

**Do not disassemble or repair the product randomly.**

- It will cause a fire or electrical shock.

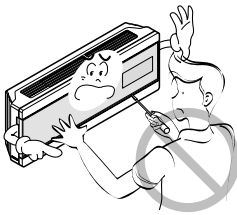

**Do not install the product at a place that there is concern of falling down.**

- Otherwise, it may result in personal injury.

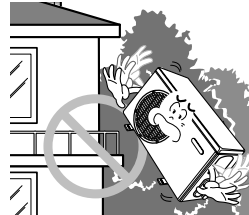

**Use caution when unpacking and installing.**

- Sharp edges may cause injury.

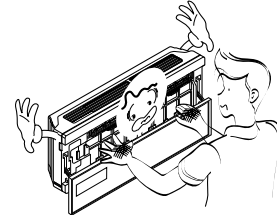

## Operation

**Do not share the outlet with other appliances.**

- It will cause an electric shock or a fire due to heat generation.

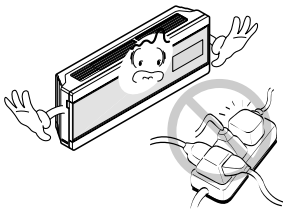

**Do not use the damaged power cord.**

- Otherwise, it may cause a fire or electrical shock.

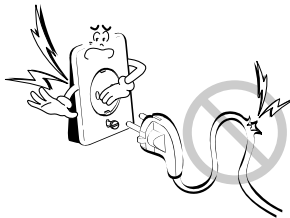

**Do not modify or extend the power cord randomly.**

- Otherwise, it may cause a fire or electrical shock.

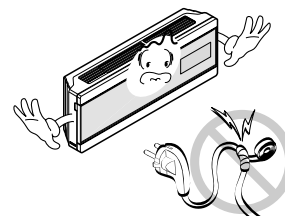

**Take care so that the power cord may not be pulled during operation.**

- Otherwise, it may cause a fire or electrical shock.



**Unplug the unit if strange sounds, smell, or smoke comes from it.**

- Otherwise, it may cause electrical shock or a fire.



**Keep the flames away.**

- Otherwise, it may cause a fire.

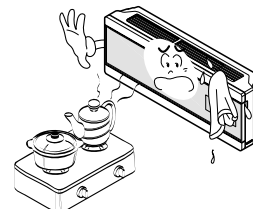

Take the power plug out if necessary, holding the head of the plug and do not touch it with wet hands.

- Otherwise, it may cause a fire or electrical shock.

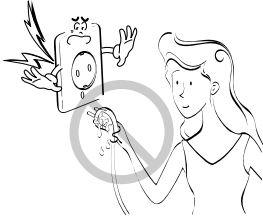

Do not use the power cord near the heating tools.

- Otherwise, it may cause a fire and electrical shock.

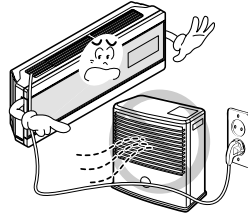

Do not open the suction inlet of the indoor/outdoor unit during operation.

- Otherwise, it may electrical shock and failure.

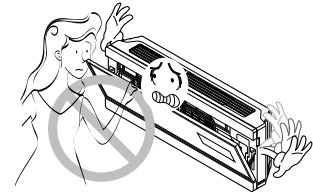

Do not allow water to run into electrical parts.

- Otherwise, it may cause the failure of machine or electrical shock.



Hold the plug by the head when taking it out.

- It may cause electric shock and damage.

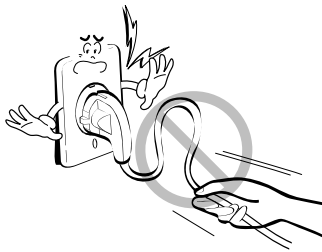

Never touch the metal parts of the unit when removing the filter.

- They are sharp and may cause injury.

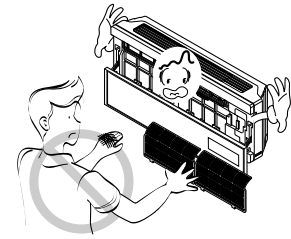

Do not step on the indoor/outdoor unit and do not put anything on it.

- It may cause an injury through dropping of the unit or falling down.



Do not place a heavy object on the power cord.

- Otherwise, it may cause a fire or electrical shock.

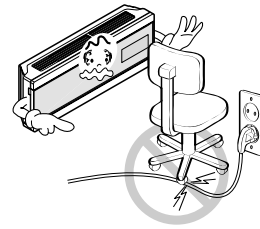

When the product is submerged into water, always contact the service center.

- Otherwise, it may cause a fire or electrical shock.



Take care so that children may not step on the outdoor unit.

- Otherwise, children may be seriously injured due to falling down.

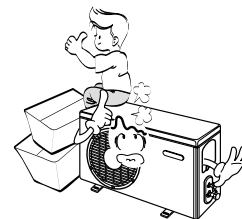

**CAUTION**

**Installation**

Install the drain hose to ensure that drain can be securely done.

- Otherwise, it may cause water leakage.

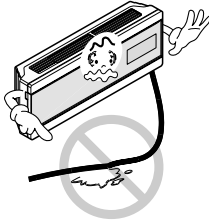

Install the product so that the noise or hot wind from the outdoor unit may not cause any damage to the neighbors.

- Otherwise, it may cause dispute with the neighbors.

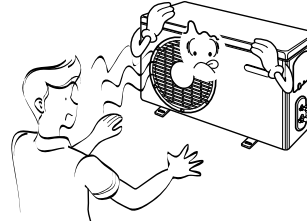

Always inspect gas leakage after the installation and repair of product.

- Otherwise, it may cause the failure of product.

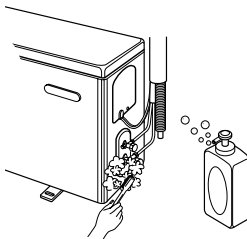

Keep level parallel in installing the product.

- Otherwise, it may cause vibration or water leakage.

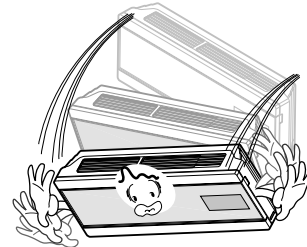

**Operation**

Avoid excessive cooling and perform ventilation sometimes.

- Otherwise, it may do harm to your health.

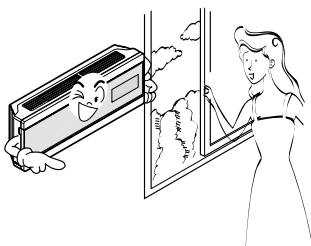

Use a soft cloth to clean. Do not use wax, thinner, or a strong detergent.

- The appearance of the air conditioner may deteriorate, change color, or develop surface flaws.

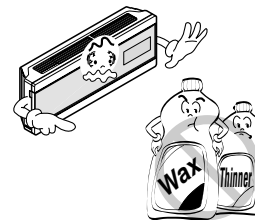

Do not use an appliance for special purposes such as preserving animals vegetables, precision machine, or art articles.

- Otherwise, it may damage your properties.

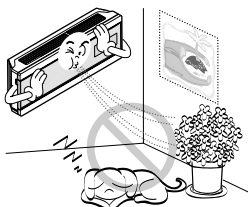

Do not place obstacles around the flow inlet or outlet.

- Otherwise, it may cause the failure of appliance or an accident.

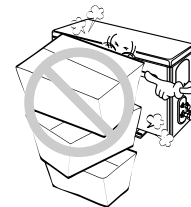

# Dimensions

## Symbols used in this Manual



This symbol alerts you to the risk of electric shock.



This symbol alerts you to hazards that may cause harm to the air conditioner.

**NOTICE**

This symbol indicates special notes.

## Indoor Unit

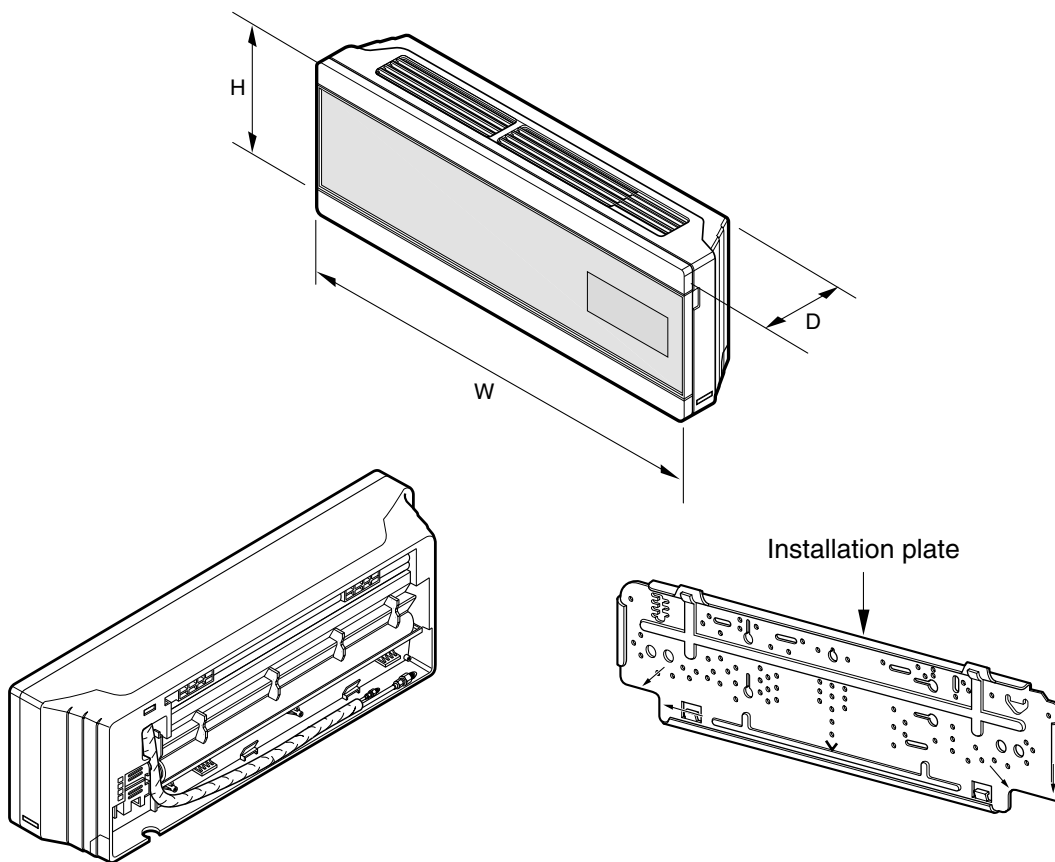

DIM	MODEL	14K Btu Series
	Unit	
W	mm	1030
H	mm	290
D	mm	153

**Outdoor Unit**

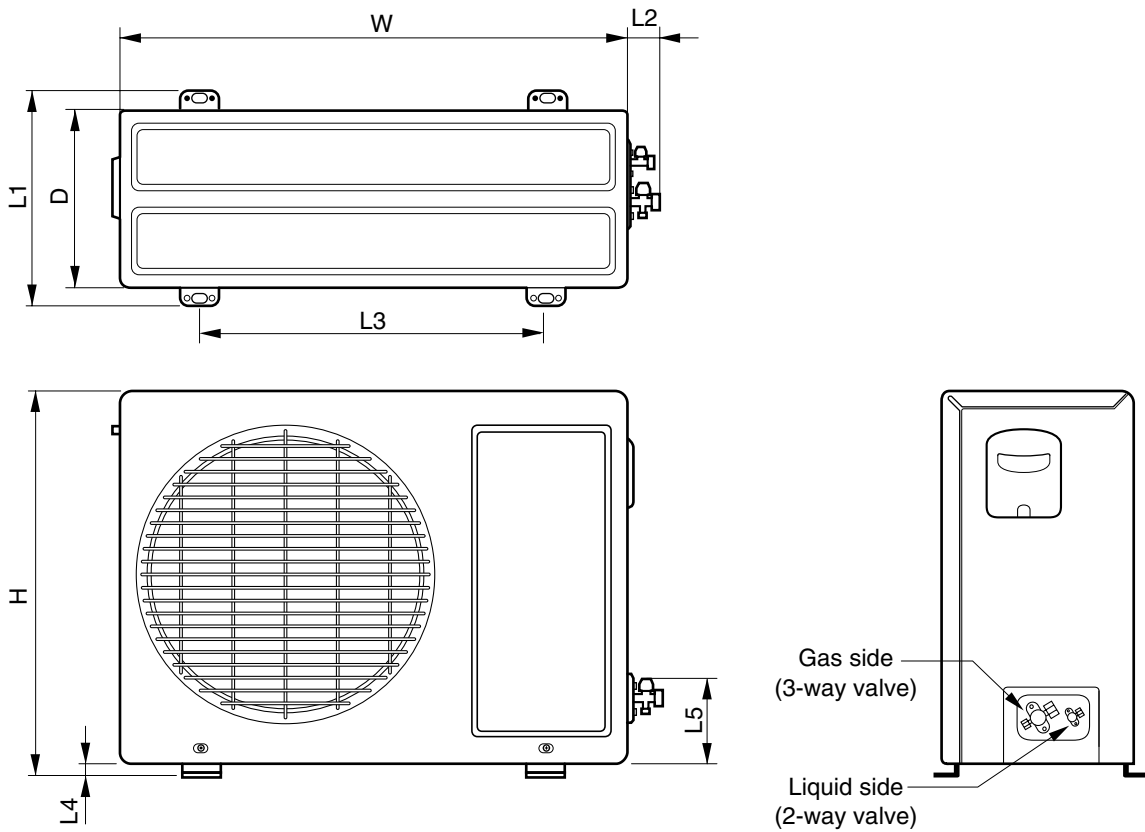

DIM	MODEL	
	unit	14K Btu Series
W	mm	770
H	mm	540
D	mm	245
L1	mm	285
L2	mm	64
L3	mm	518
L4	mm	10
L5	mm	100

# Product Specifications

**Table-1**

Item		Model Name		LA140CE
		Unit		
Cooling Capacity		Btu/h	14000	
Heating Capacity			-	
Moisture Removal		l/h	1.5	
Power Source		Ø, V, Hz	1Ø, 115V, 60Hz	
Air Circulation	Indoor	m <sup>3</sup> /min	9	
	Outdoor		26	
Noise Level	Indoor	dB (A)±3	41	
	Outdoor		48	
Input	Cooling	W	1400	
	Heating		-	
Running Current	Cooling	A	13	
	Heating		-	
E.E.R.	Cooling	Btu/hW	10.0	
C.O.P	Heating		-	
Motor Output	Indoor	W	24	
	Outdoor		27	
Dimensions (W x H x D)	Indoor	mm	1030 x 290 x 153	
	Outdoor		770 x 540 x 245	
Net. Weight	Indoor	kg	9.5	
	Outdoor		35	
Refrigerant		g	900(R22)	
Airflow Direction Control (Up & Down)			O	
Remocon Type			L.C.D Wireless	
Service Valve	Liquid	inch(mm)	1/4(6.35)	
	Gas		1/2(12.7)	
Sleeping Operation			O	
Drain Hose			O	
Connecting Cable(p*mm <sup>2</sup> )			18: 4*0.75	
Power Cord(p*mm <sup>2</sup> )			14: 3*2.5	

# Installation

## Select the best Location

### Indoor unit

1. Do not have any heat or steam near the unit.
2. Select a place where there are no obstacles in front of the unit.
3. Make sure that condensation drainage can be conveniently routed away.
4. Do not install near a doorway.
5. Ensure that the interval between a wall and the left (or right) of the unit is more than 5cm(1.96"). The unit should be installed as high as possible on the wall, allowing a minimum of 10cm(3.9") from ceiling.
6. Use a stud finder to locate studs to prevent unnecessary damage to the wall.

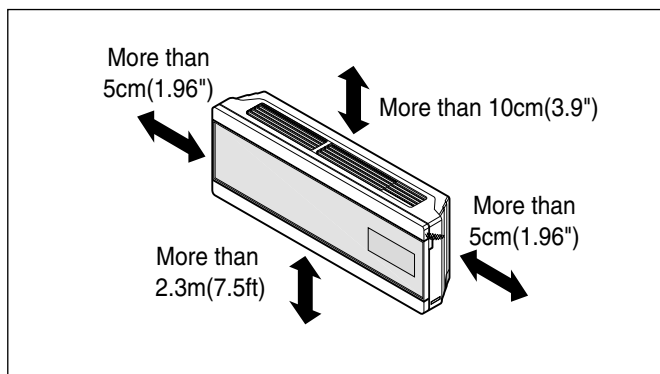

**CAUTION:** Install the indoor unit on the wall where the height from the floor is more than 2 meters (6.6ft).

### Outdoor unit

1. If an awning is built over the unit to prevent direct sunlight or rain exposure, make sure that heat radiation from the condenser is not restricted.
2. Ensure that the space around the back and sides is more than 10cm(3.9"). The front of the unit should have more than 70cm(28") of space.
3. Do not place animals and plants in the path of the warm air.
4. Take the weight of the air conditioner into account and select a place where noise and vibration are minimum.
5. Select a place where the warm air and noise from the air conditioner do not disturb neighbors.

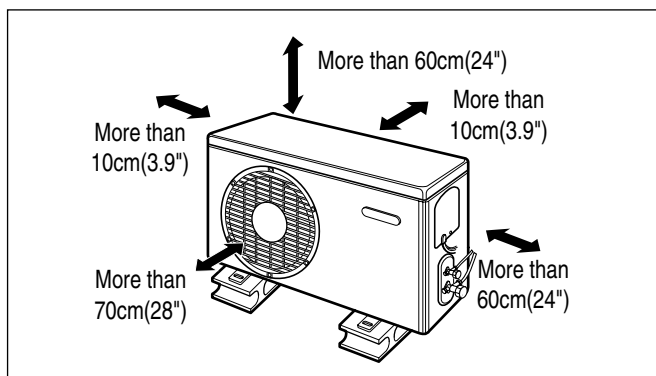

## Piping Length and Elevation

Capacity (Btu/h)	Pipe Size		Standard Length (m)	Max. Elevation B (m)	Max. Length A (m)	Additional Refrigerant (g/m)
	GAS	LIQUID				
14K	1/2"	1/4"	7.5(24.6ft)	7(23ft)	15(50ft)	20

**CAUTION:** Capacity is based on standard length and maximum allowance length is on the basis of reliability. Oil trap should be installed every 5~7 meters(16.4~23ft).

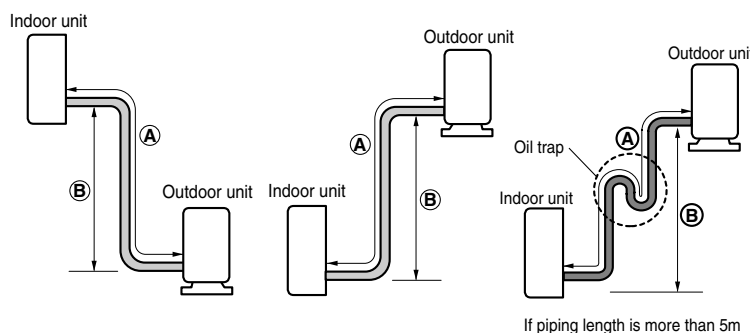

## Fixing Installation Plate

The wall you select should be strong and solid enough to prevent vibration

1. Mount the installation plate on the wall with type "A" screws. If mounting the unit on a concrete wall, use anchor bolts.
- Mount the installation plate horizontally by aligning the centerline using a level.

2. Measure the wall and mark the centerline. It is also important to use caution concerning the location of the installation plate—routing of the wiring to power outlets is through the walls typically. Drilling the hole through the wall for piping connections must be done safely.

CHASSIS (Grade)	Distance (mm)			
	A	B	C	D
SU (11k~14k)	92	44	67	44

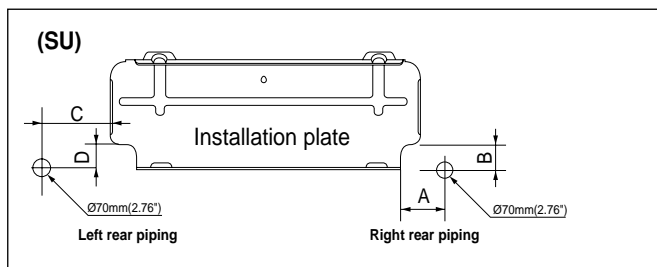
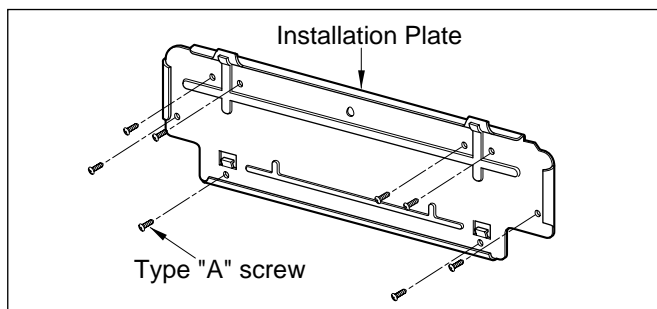

## Drill a Hole in the Wall

- Drill the piping hole with a  $\varnothing 70\text{mm}(2.76'')$  hole core drill. Drill the piping hole at either the right or the left with the hole slightly slanted to the outdoor side.

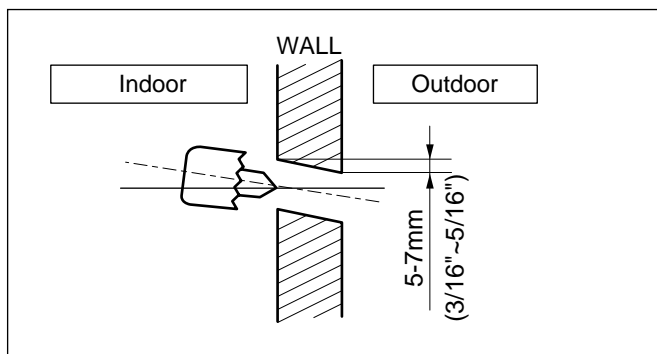

## Flaring Work

Main cause for gas leakage is due to defect in flaring work. Carry out correct flaring work in the following procedure.

### Cutting the pipes and the cable.

1. Use the piping kit accessory or the pipes purchased locally.
2. Measure the distance between the indoor and the outdoor unit.
3. Cut the pipes a little longer than measured distance.
4. Cut the cable 1.5m longer than the pipe length.

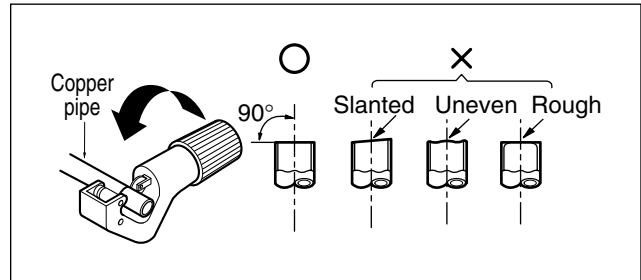

### Removing burrs

1. Completely remove all burrs from the cut cross section of pipe/tube.
2. Put the end of the copper tube/pipe in a downward direction as you remove burrs in order to avoid dropping burrs into the tubing.

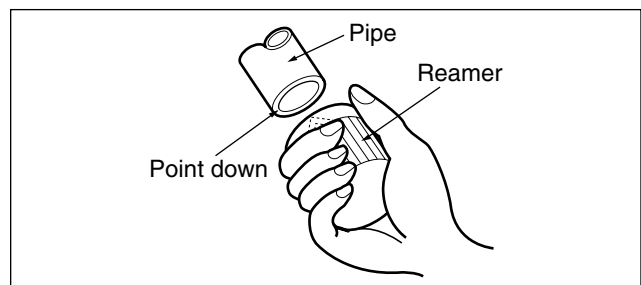

### Putting nut on

- Remove flare nuts attached to indoor and outdoor unit, then put them on pipe/tube having completed burr removal.  
(not possible to put them on after flaring work)

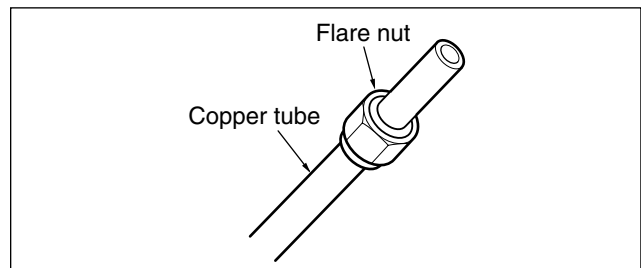

### Flaring work

1. Firmly hold copper pipe in a die in the dimension shown in the table below.
2. Carry out flaring work with the flaring tool.

Outside diameter		A
mm	inch	mm
Ø6.35	1/4	0~0.5
Ø9.52	3/8	0~0.5
Ø12.7	1/2	0~0.5
Ø15.88	5/8	0~1.0
Ø19.05	3/4	1.0~1.3

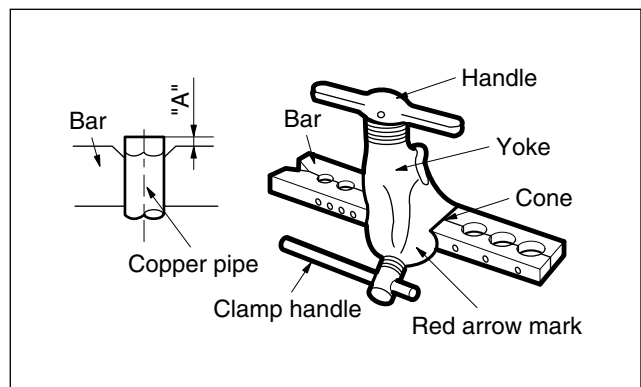

## Check

1. Compare the flared work with the figure by.
2. If a flared section is defective, cut it off and do flaring work again.

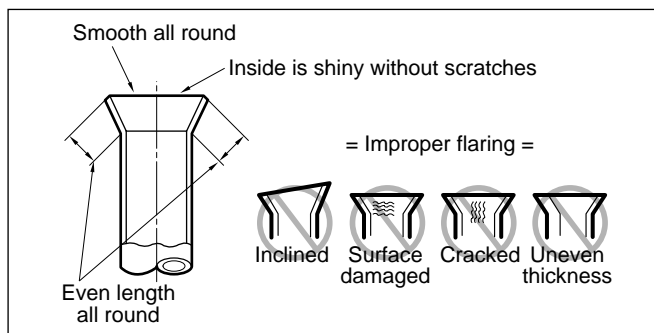

## Connecting the Piping

### Indoor

1. Prepare the indoor unit's piping and drain hose for installation through the wall.
2. Remove the plastic tubing retainer(see the illustration by) and pull the tubing and drain hose away from chassis.
3. Replace only the plastic tubing holder 1, not the holder 2 in the original position.

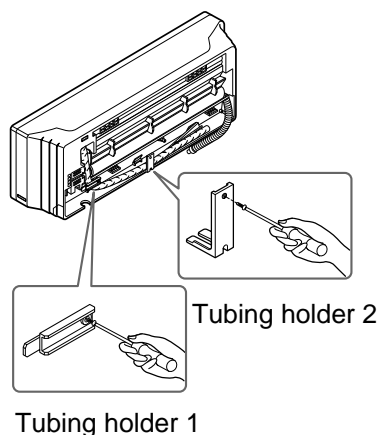

### For right rear piping

1. Route the indoor tubing and the drain hose in the direction of rear right.
2. Insert the connecting cable into the indoor unit from the outdoor unit through the piping hole.
  - Do not connect the cable to the indoor unit.
  - Make a small loop with the cable for easy connection later.
3. Tape the tubing, drain hose, and the connecting cable. Be sure that the drain hose is located at the lowest side of the bundle. Locating at the upper side can cause drain pan to overflow inside the unit.



**CAUTION:** If the drain hose is routed inside the room, insulate the hose with an insulation material\* so that dripping from "sweating"(condensation) will not damage furniture or floors.

\*Foamed polyethylene or equivalent is recommended.

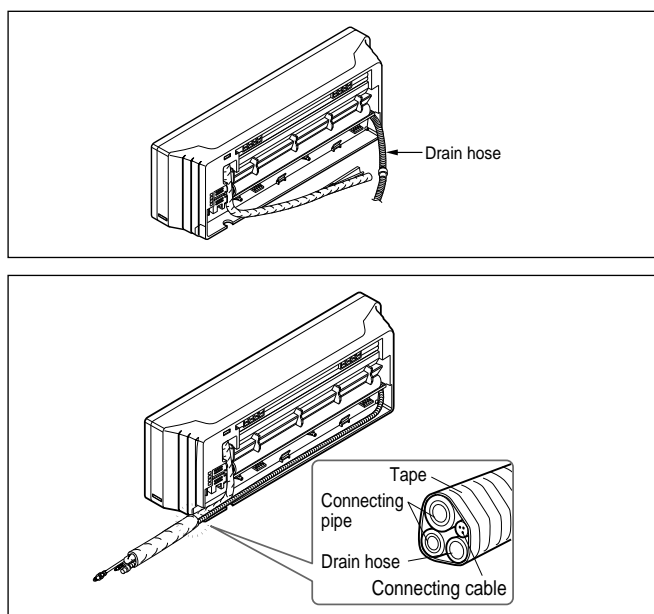

4. Indoor unit installation

Hook the indoor unit onto the upper portion of the installation plate. (Engage the two hooks of the rear top of the indoor unit with the upper edge of the installation plate.) Ensure that the hooks are properly seated on the installation plate by moving it left and right.

Press the lower left and right sides of the unit against the installation plate until the hooks engage into their slots (clicking sound).

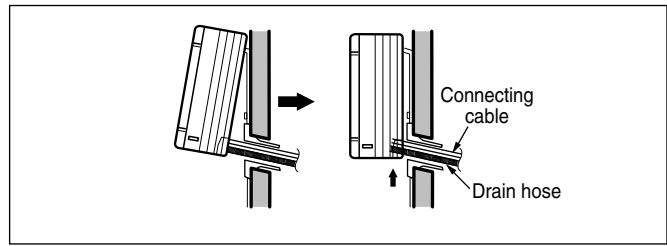

**Connecting the piping to the indoor unit and drain hose to drain pipe.**

1. Align the center of the pipes and sufficiently tighten the flare nut by hand.

2. Tighten the flare nut with a wrench.

Outside diameter		Torque
mm	inch	kg-m
Ø6.35	1/4	1.8
Ø9.52	3/8	4.2
Ø12.7	1/2	5.5

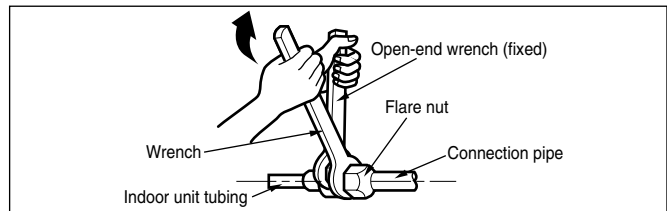
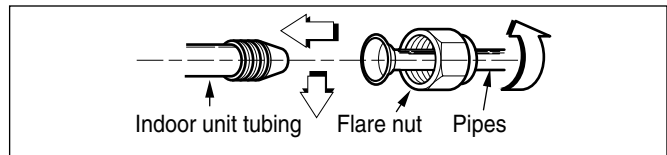

3. When extending the drain hose at the indoor unit, install the drain pipe.

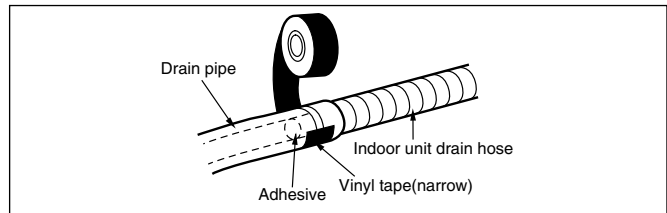

**Wrap the insulation material around the connecting portion.**

1. Overlap the connection pipe insulation material and the indoor unit pipe insulation material. Bind them together with vinyl tape so that there may be no gap.

2. Wrap the area which accommodates the rear piping housing section with vinyl tape.

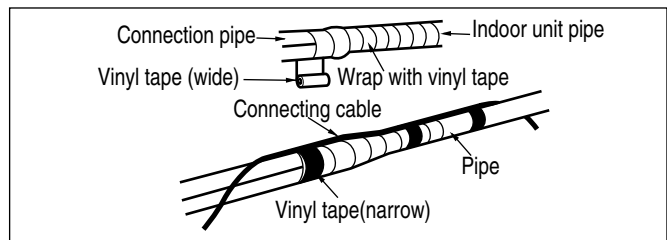
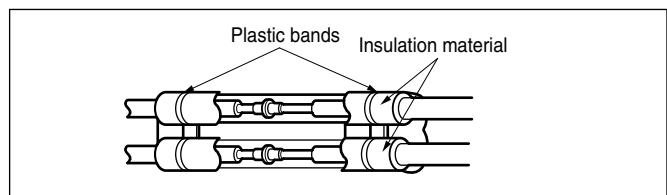

3. Bundle the piping and drain hose together by wrapping them with vinyl tape for enough to cover where they fit into the rear piping housing section.

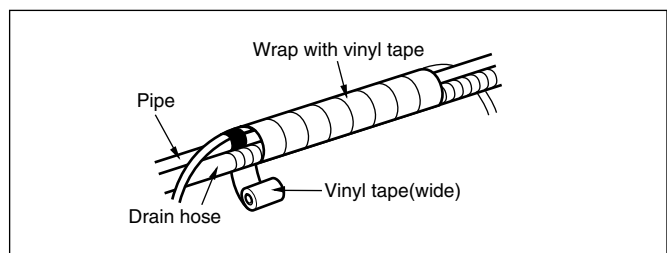

**For left rear piping**

1. Route the indoor tubing and the drain hose to the required piping hole position.
2. Insert the piping, drain hose, and the connecting cable into the piping hole.
3. Insert the connecting cable into the indoor unit.
  - Don't connect the cable to the indoor unit.
  - Make a small loop with the cable for easy connection later.
4. Tape the drain hose and the connecting cables.

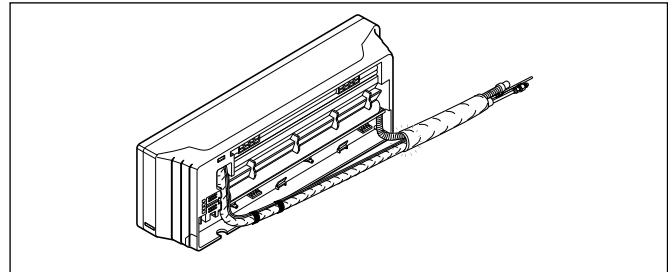
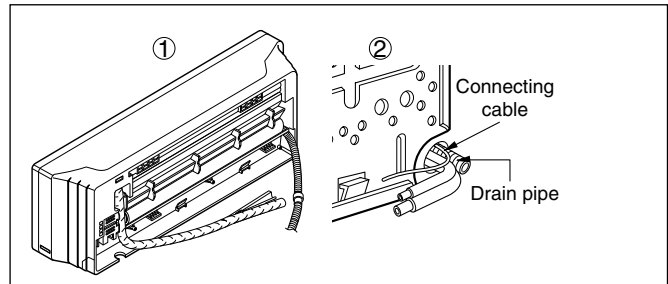

5. Indoor unit installation
  - Hang the indoor unit from the hooks at the top of the installation plate.
  - Insert the spacer etc. between the indoor unit and the installation plate and separate the bottom of the indoor unit from the wall.

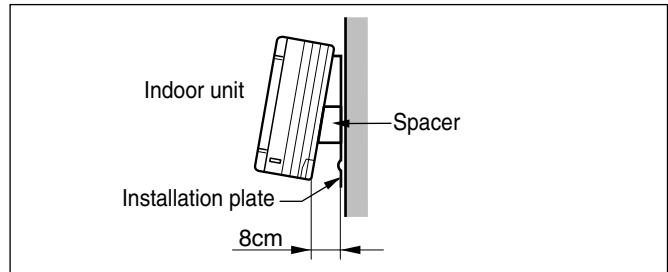

**Connecting the piping to the indoor unit and the drain hose to drain pipe.**

1. Align the center of the pipes and sufficiently tighten the flare nut by hand.

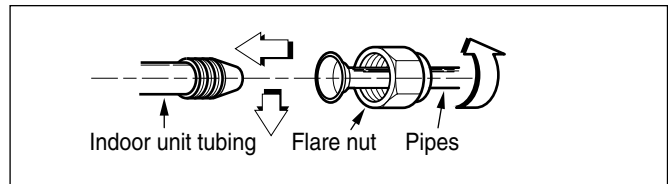

2. Tighten the flare nut with a wrench.

Outside diameter		Torque
mm	inch	kg·m
Ø6.35	1/4	1.8
Ø9.52	3/8	4.2
Ø12.7	1/2	5.5

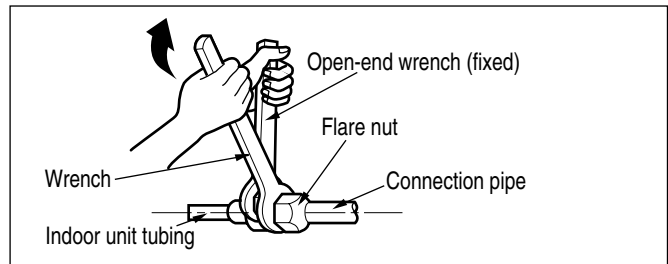

3. When extending the drain hose at the indoor unit, install the drain pipe.

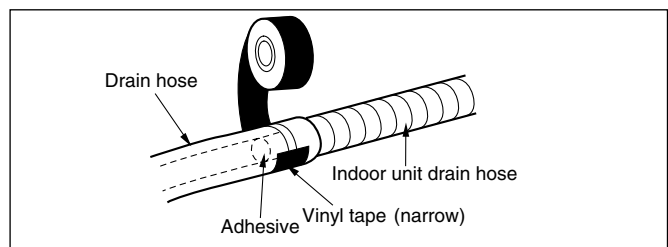

**Wrap the insulation material around the connecting portion.**

1. Overlap the connection pipe heat insulation and the indoor unit pipe heat insulation material. Bind them together with vinyl tape so that there may be no gap.
2. Wrap the area which accommodates the rear piping housing section with vinyl tape.

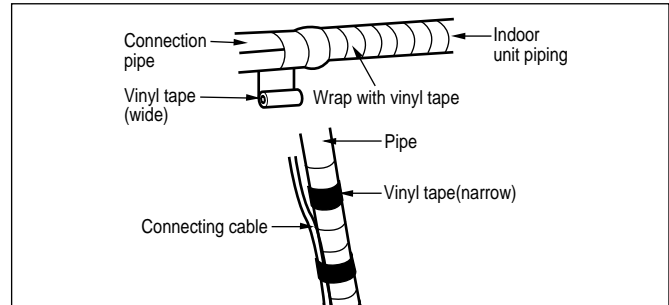
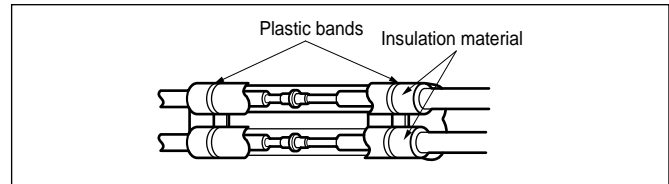

3. Bundle the piping and drain hose together by wrapping them with cloth tape over the range within which they fit into the rear piping housing section.

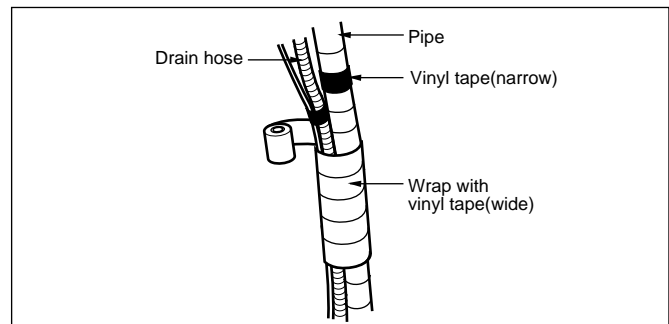

**Reroute the pipings and the drain hose across the back of the chassis.**

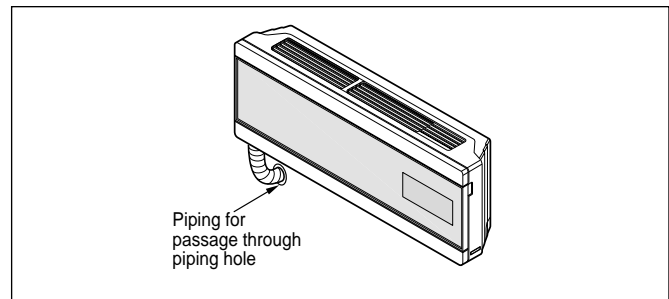

**Indoor unit installation**

1. Remove the spacer.
2. Ensure that the hooks are properly seated on the installation plate by moving it left and right.
3. Press the lower left and right sides of the unit against the installation plate until the hooks engage into their slots (clicking sound).

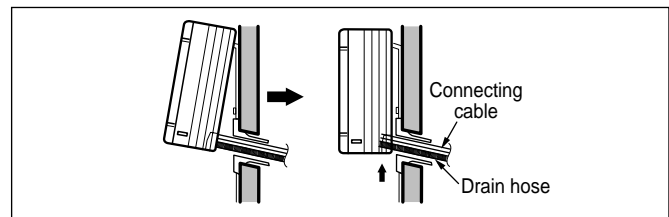

**! CAUTION: Installation Information**  
**For left piping. Follow the instruction below.**

**Good case**

- Press on the upper side of clamp and unfold the tubing to downward slowly.

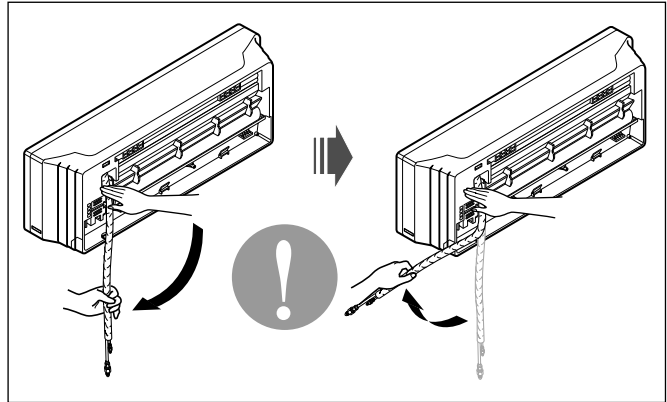

**Bad case**

- Following bending type from right to left may cause damage to the tubing.

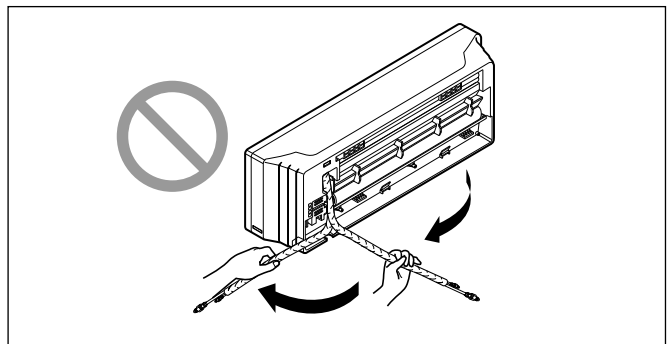

**Outdoor**

Align the center of the pipings and sufficiently tighten the flare nut by hand.

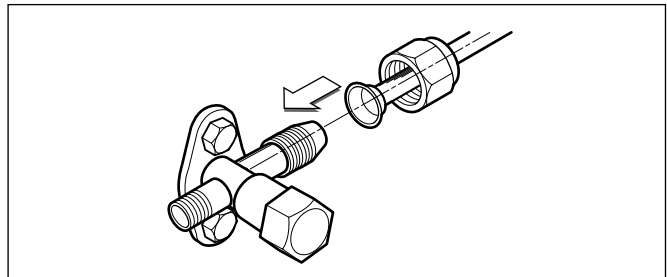

Finally, tighten the flare nut with torque wrench until the wrench clicks.

- When tightening the flare nut with torque wrench, ensure the direction for tightening follows the arrow on the wrench.

Outside diameter		Torque
mm	inch	kg.m
Ø6.35	1/4	1.8
Ø9.52	3/8	4.2
Ø12.7	1/2	5.5
Ø15.88	5/8	6.6
Ø19.05	3/4	6.6

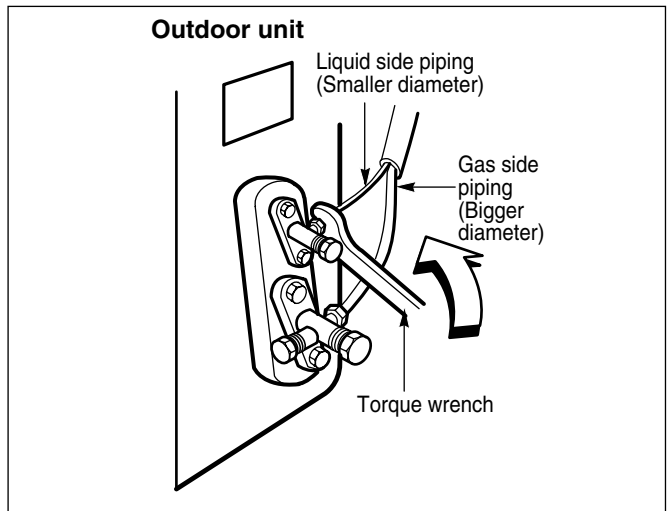

## Connecting the Cables

1. Remove the cover control from the unit by loosening the 3 screws.
2. Dismount caps on the conduit panel.
3. Temporarily mount the conduit tubes on the conduit panel.
4. Properly connect both the power supply and low voltage lines to the corresponding terminals on the terminal block.
5. Ground the unit in accordance with local codes.
6. Be sure to size each wire allowing several inches longer than the required length for wiring.
7. Use lock nuts to secure the conduit tubes.

### NOTICE

Connector trade size for this unit is 1/2". Refer to "How to connect wiring to the terminals" for instructions on connecting depending on the wire type you are using.

### ! WARNING:

- Be sure to comply with local codes while running the wire from the indoor unit to the outdoor unit (size of wire and wiring method, etc).
- Every wire must be connected firmly.
- No wire should be allowed to touch refrigerant tubing, the compressor or any moving parts.

### Power Supply

Model	Power source	AWG(MIN)		Fuse or breaker Capacity
		Ⓐ	Ⓑ	
14K	1Ø, 115V	14	18	20A

### Wiring Diagram

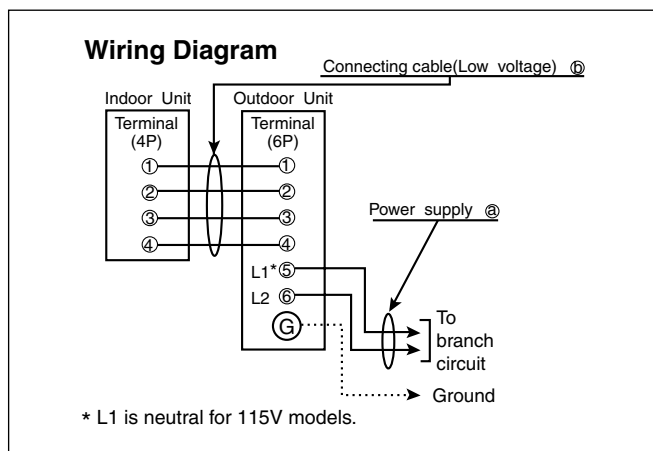

### NOTICE

1. shows field wiring.
2. Separately wire the high and low voltage line.
3. Use heat-proof electrical wiring capable of withstanding temperatures up to 167°F.
4. Use outdoor and waterproof connection cable rated more than 300V for the connection between indoor and outdoor unit.  
(For example, Type SJO-WA)

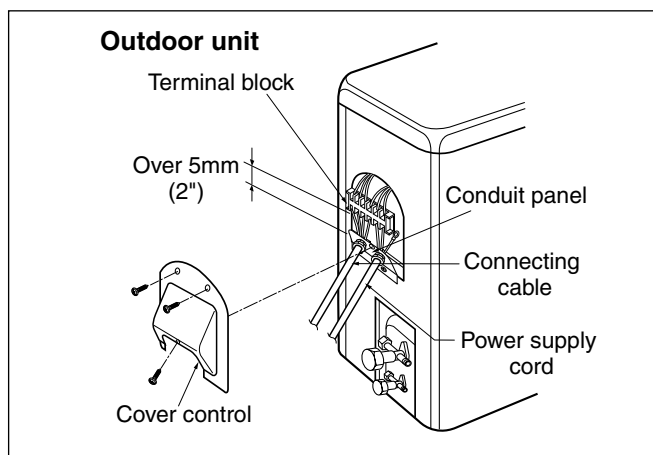

## Connection method of the connecting cable(Example)

1. Dismount two-caps on the conduit panel.
2. Make a hole appropriate for the passage of connection cable through on cap by tool. (for low voltage line)
3. Pass the connecting cable through the hole.
4. Properly connect the cable on the terminal block.
5. Fix the connection cable with clamp cord provided on the unit not to have strain at the terminal when the connection cable is pulled outside up to a 35 pound weight.
6. Wind the vinyl tape round the connecting cable for sealing between the surface of the connection cable and cap.
7. Mount the taped part of cable on the cap.
8. Finally, mount the holed cap with the wound cable on the conduit panel.



### WARNING:

**Loose wiring may cause the terminal to over-heat or result in unit malfunction. A fire hazard may also exist. Therefore, be sure all wiring is tightly connected.**

When connecting each power wire to the corresponding terminal, follow instructions "How to connect wiring to the terminals" and fasten the wire tightly with the fixing screw of the terminal plate.

### How to connect wiring to the terminals

- For solid core wiring (or F-cable)
  1. Cut the wire end with a wire cutter or wire-cutting pliers, then strip the insulation to expose the solid wire about 25mm(15/16")
  2. Using a screwdriver, remove the terminal screw(s) on the terminal plate.
  3. Using pliers, bend the solid wire to form a loop suitable for the terminal screw.
  4. Shape the loop wire properly, place it on the terminal plate and tighten securely with the terminal screw using a screwdriver.
- For strand wiring
  1. Cut the wire end with a wire cutter or wire-cutting pliers, then strip the insulation to expose the strand wiring about 10mm(3/8").
  2. Using a screwdriver, remove the terminal screw(s) on the terminal plate.
  3. Using a round terminal fastener or pliers, securely clamp each stripped wire end with a round terminal.
  4. Position the round terminal wire, and replace and tighten the terminal screw using a screwdriver.

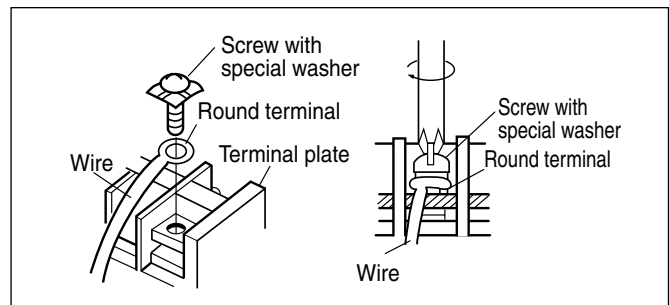
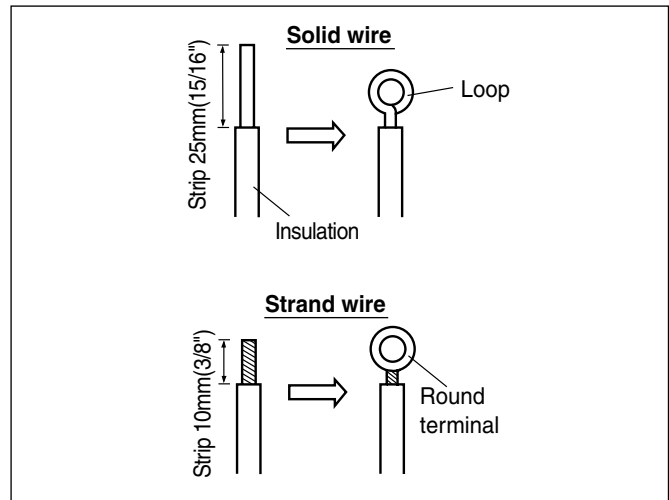
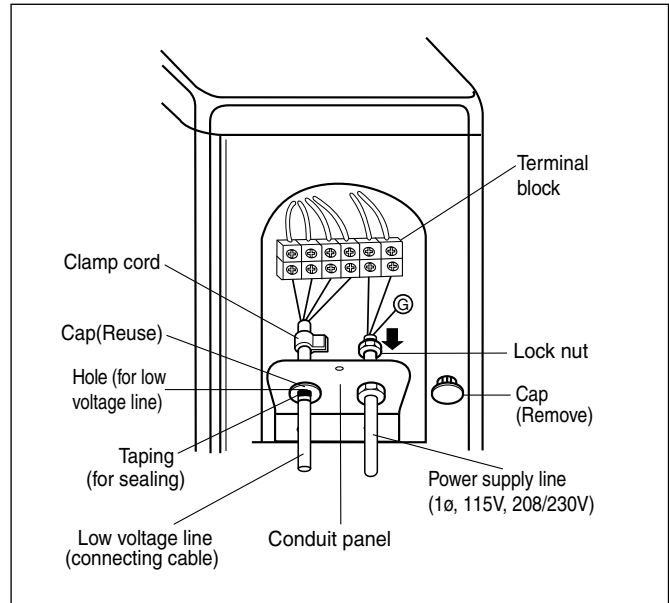

**⚠ CAUTION: Provide a circuit breaker between power source and the unit as shown below.**

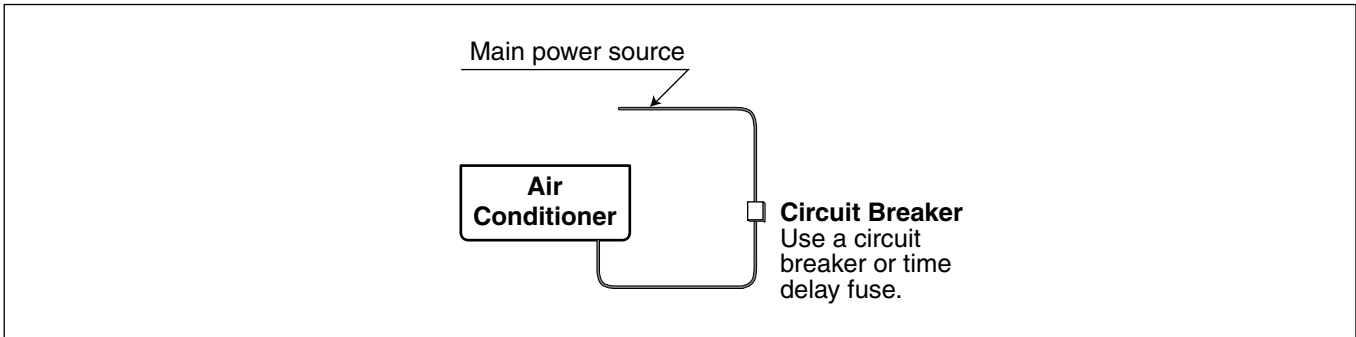

## Connect the cable to the indoor unit

1. Connect the wires to the terminals on the control board individually according to the outdoor unit connection.
  - Ensure that the color of the wires of outdoor unit and the terminal No. are the same as those of indoor unit respectively.

### ⚠ WARNING:

- Be sure to refer to the wiring diagram label inside the cover control and carry out the correct field wiring. Wrong wiring can cause the unit to misoperate to result in a fire hazard.
- Check local electrical codes and any specified wiring instructions or limitations.

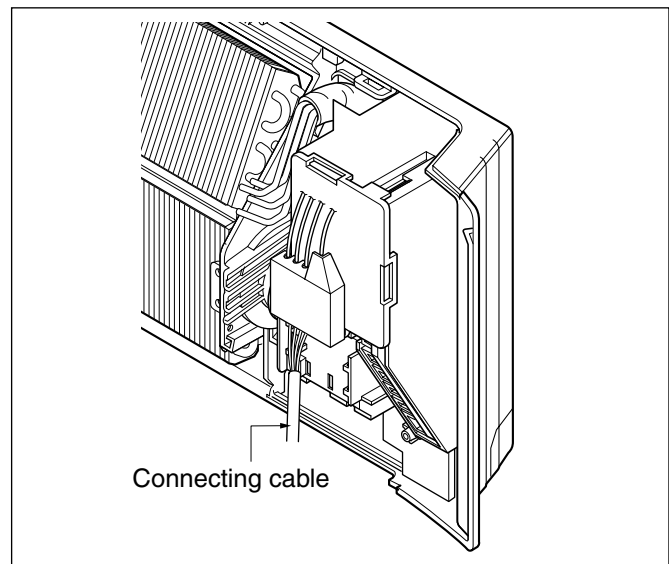

2. Attach the Grille onto the cabinet.
  - Grasp the lower left and right side of the Grille and engage four tabs on the top inside edge of the chassis.
  - Press the Grille toward the chassis until it will be back into place.

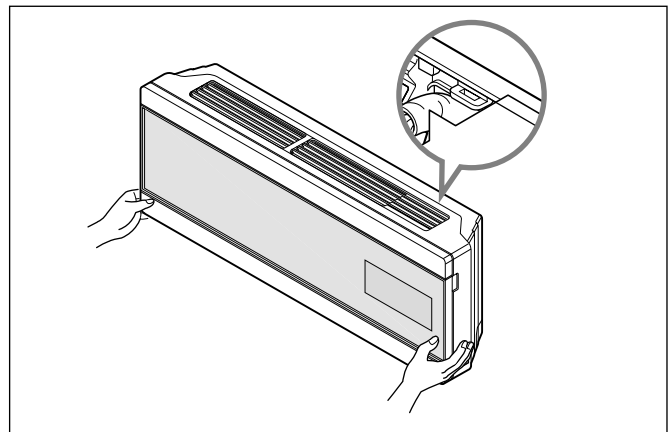

## Checking the Drainage

### To check the drainage.

1. Pour a glass of water on the evaporator.
2. Ensure the water flows through the drain hose of the indoor unit without any leakage and goes out the drain exit.

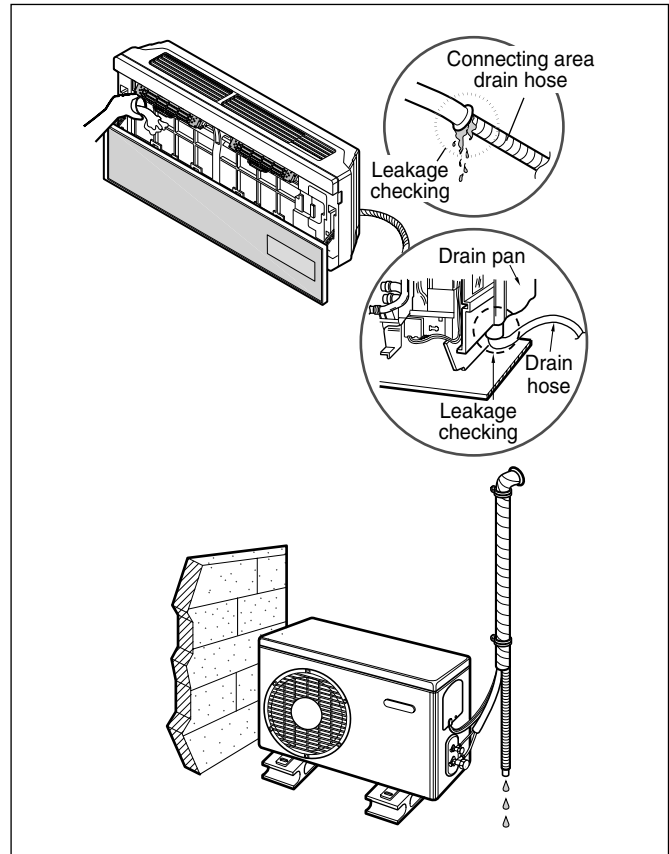

### Drain piping

1. The drain hose should point downward for easy drain flow.

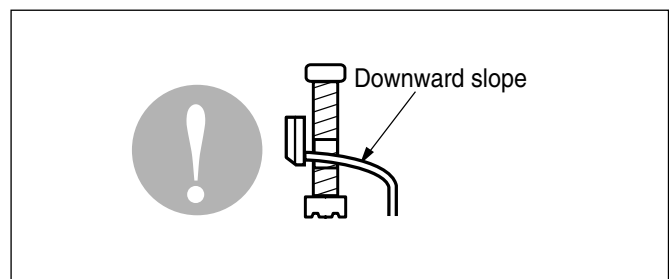

2. Do not make drain piping like the following.

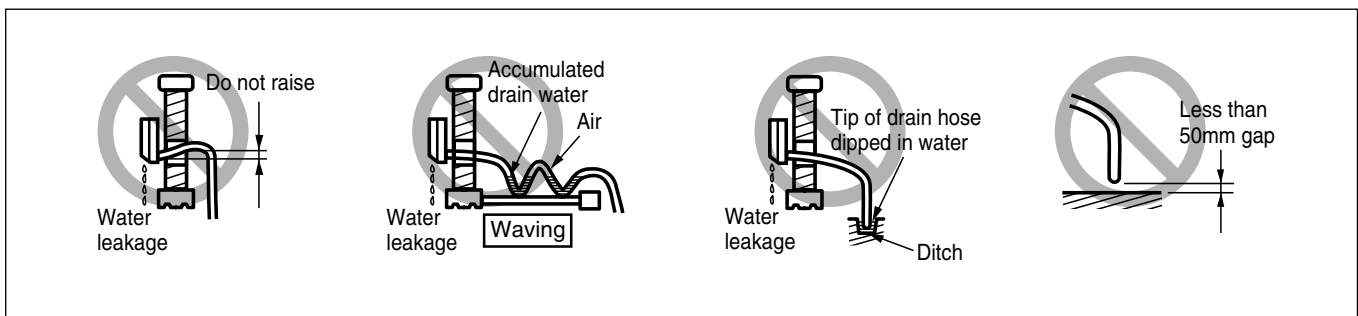

## Forming the Piping

**Form the piping by wrapping the connecting portion of the indoor unit with insulation material and secure it with two kinds of vinyl tapes.**

- If you want to connect an additional drain hose, the end of the drain outlet should be routed above the ground. Secure the drain hose appropriately.

**In cases where the outdoor unit is installed below the indoor unit perform the following.**

1. Tape the piping, drain hose and connecting cable from down to up.
2. Secure the tapped piping along the exterior wall using saddle or equivalent.

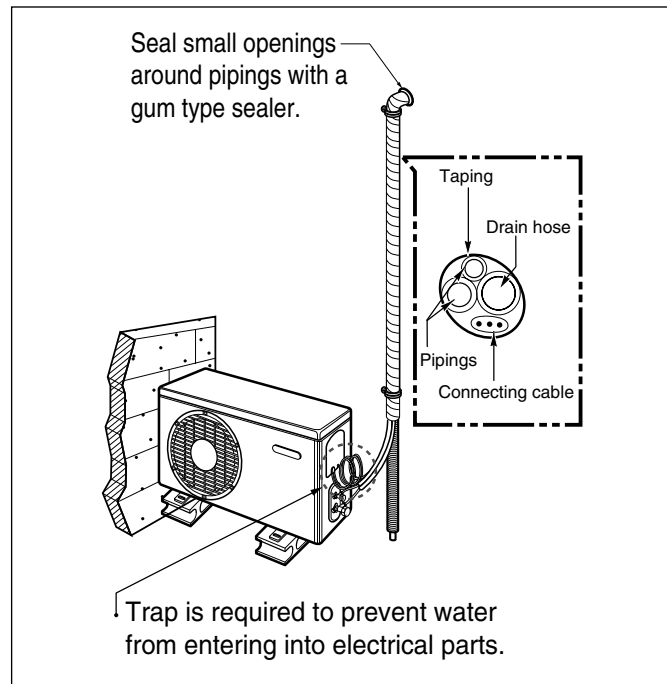

**In cases where the Outdoor unit is installed above the Indoor unit perform the following.**

1. Tape the piping and connecting cable from down to up.
2. Secure the taped piping along the exterior wall. Form a trap to prevent water entering the room.
3. Fix the piping onto the wall by saddle or equivalent.

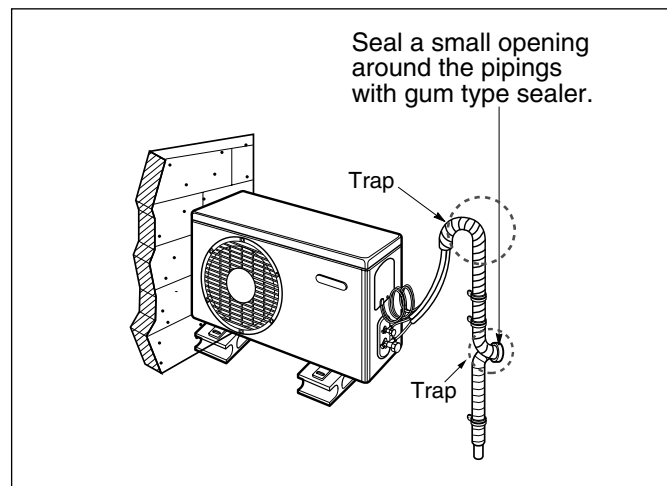

## Air Purging

### Air purging

The air and moisture remaining in the refrigerant system have undesirable effects as indicated below.

1. Pressure in the system rises.
2. Operating current rises.
3. Cooling(or heating) efficiency drops.
4. Moisture in the refrigerant circuit may freeze and block capillary tubing.
5. Water may lead to corrosion of parts in the refrigeration system.

Therefore, after evacuating the system, take a leak test for the piping and tubing between the indoor and outdoor unit.

### Air purging with vacuum pump

#### 1. Preparation

- Check that each tube(both liquid and gas side tubes) between the indoor and outdoor units have been properly connected and all wiring for the test run has been completed. Remove the service valve caps from both the gas and the liquid side on the outdoor unit. Note that both the liquid and the gas side service valves on the outdoor unit are kept closed at this stage.

#### 2. Leak test

- Connect the manifold valve(with pressure gauges) and dry nitrogen gas cylinder to this service port with charge hoses.

**⚠ CAUTION: Be sure to use a manifold valve for air purging. If it is not available, use a stop valve for this purpose. The "Hi" knob of the manifold valve must always be kept close.**

- Pressurize the system to no more than 150 P.S.I.G. with dry nitrogen gas and close the cylinder valve when the gauge reading reached 150 P.S.I.G. Next, test for leaks with liquid soap.

**⚠ CAUTION: To avoid nitrogen entering the refrigerant system in a liquid state, the top of the cylinder must be higher than its bottom when you pressurize the system. Usually, the cylinder is used in a vertical standing position.**

1. Do a leak test of all joints of the tubing(both indoor and outdoor) and both gas and liquid side service valves. Bubbles indicate a leak. Be sure to wipe off the soap with a clean cloth.

2. After the system is found to be free of leaks, relieve the nitrogen pressure by loosening the charge hose connector at the nitrogen cylinder. When the system pressure is reduced to normal, disconnect the hose from the cylinder.

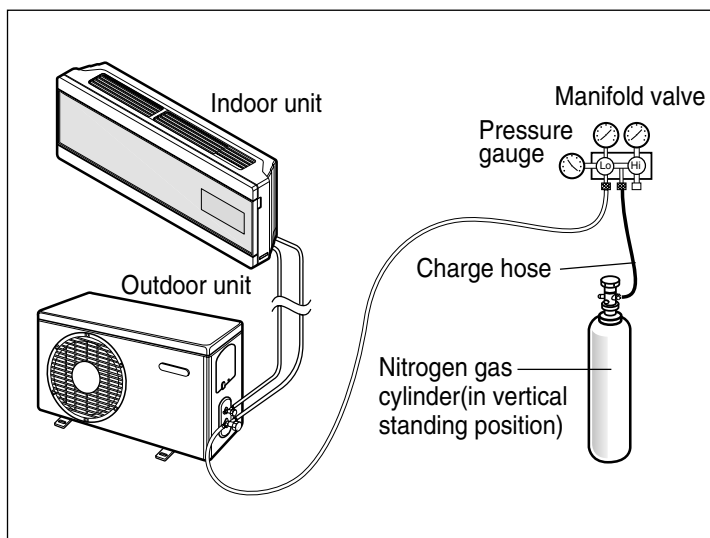

### Soap water method

1. Remove the caps from the 2-way and 3-way valves.
2. Remove the service-port cap from the 3-way valve.
3. To open the 2-way valve turn the valve stem counterclockwise approximately 90°, wait for about 2~3 sec, and close it.
4. Apply a soap water or a liquid neutral detergent on the indoor unit connection or outdoor unit connections by a soft brush to check for leakage of the connecting points of the piping.
5. If bubbles come out, the pipes have leakage

### Evacuation

1. Connect the charge hose end described in the preceding steps to the vacuum pump to evacuate the tubing and indoor unit.

Confirm the "Lo" knob of the manifold valve is open. Then, run the vacuum pump.

The operation time for evacuation varies with tubing length and capacity of the pump. The following table shows the time required for evacuation.

Required time for evacuation when 30 gal/h vacuum pump is used	
If tubing length is less than 10m (33 ft)	If tubing length is longer than 10m (33 ft)
10 min. or more	15 min. or more

2. When the desired vacuum is reached, close the "Lo" knob of the manifold valve and stop the vacuum pump.

### Finishing the job

1. With a service valve wrench, turn the valve stem of liquid side valve counter-clockwise to fully open the valve.
2. Turn the valve stem of gas side valve counter-clockwise to fully open the valve.
3. Loosen the charge hose connected to the gas side service port slightly to release the pressure, then remove the hose.
4. Replace the flare nut and its bonnet on the gas side service port and fasten the flare nut securely with an adjustable wrench. This process is very important to prevent leakage from the system.
5. Replace the valve caps at both gas and liquid side service valves and fasten them tight.

This completes air purging with a vacuum pump. The air conditioner is now ready to test run.

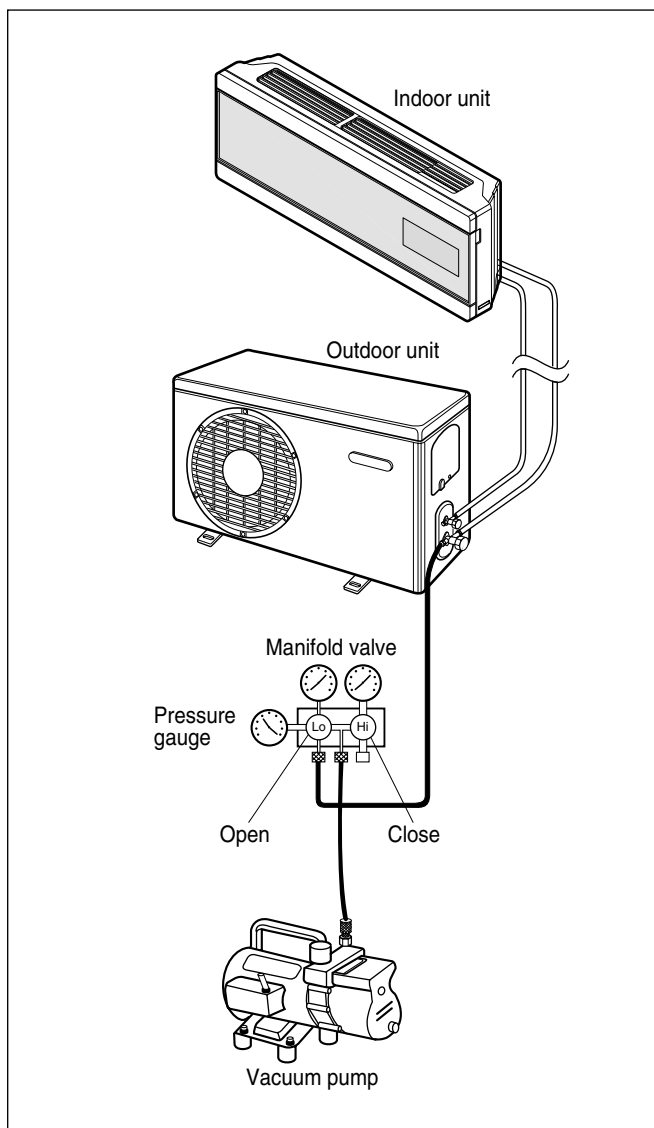
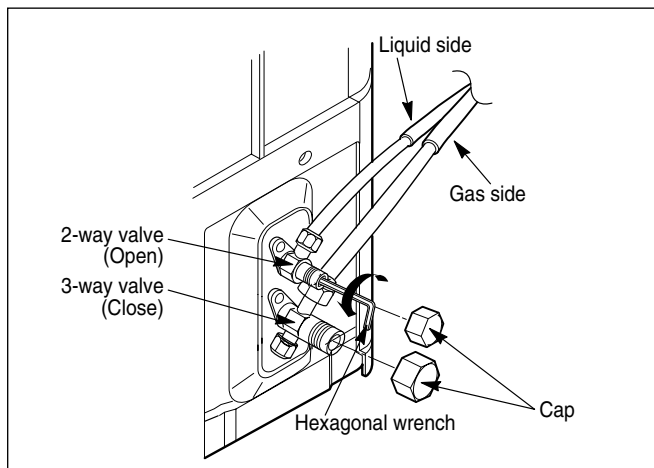

## Test Running

1. Check that all tubing and wiring are properly connected.
2. Check that the gas and liquid side service valves are fully open.

### Prepare remote controller

1. Remove the battery cover by pulling it according to the arrow direction.
2. Insert new batteries making sure that the (+) and (-) of battery are installed correctly.
3. Reattach the cover by pushing it back into position.

#### NOTICE

- Use 2 AAA(1.5volt) batteries. Do not use rechargeable batteries.
- Remove the batteries from the remote controller if the system is not used for a long time.

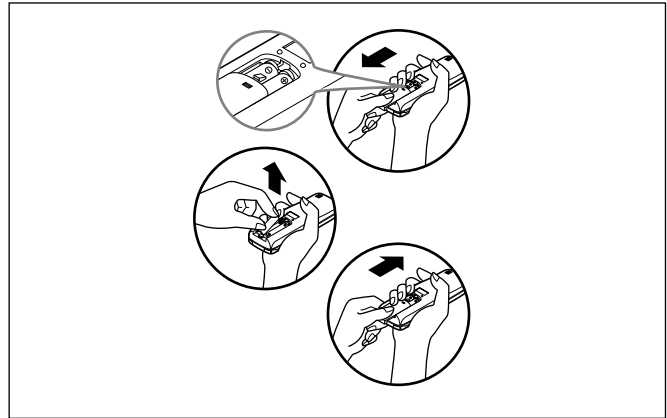

### Settlement of outdoor unit

1. Anchor the outdoor unit with a bolt and nut(ø10mm) tightly and horizontally on a concrete or rigid mount.
2. When installing on the wall, roof or rooftop, anchor the mounting base securely with a nail or wire assuming the influence of wind and earthquake.
3. If the vibration of the unit is transmitted to the hose, secure the unit with an anti-vibration rubber.

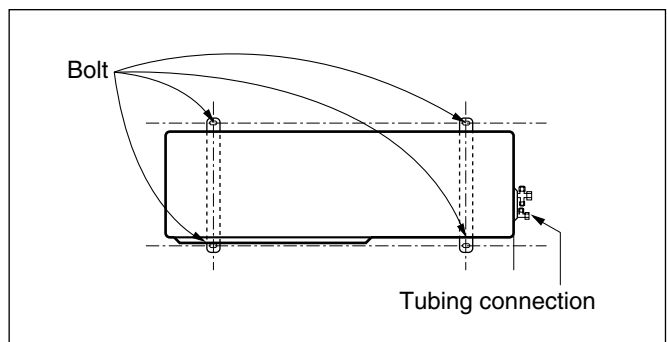

### Evaluation of the performance

Operate the unit for 15~20 minutes, then check the system refrigerant charge:

1. Measure the pressure of the gas side service valve.
2. Measure the temperature of the intake and discharge of air.
3. Ensure the difference between the intake temperature and the discharge is more than 8°C
4. For reference; the gas side pressure of optimum condition is as below.(Cooling)

The air conditioner is now ready for use.

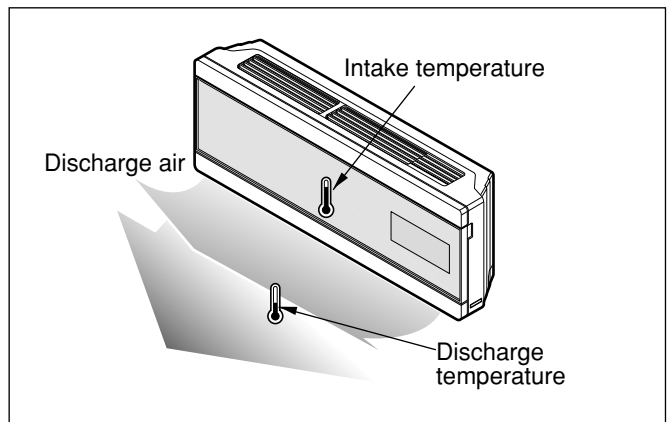

Refrigerant	Outside ambient TEMP.	The pressure of the gas side service valve.
R-22	35°C (95°F)	4~5kg/cm <sup>2</sup> G(56.8~71.0 P.S.I.G.)

**NOTICE** If the actual pressure is higher than shown, the system is most likely over-charged, and charge should be removed. If the actual pressure are lower than shown, the system is most likely undercharged, and charge should be added.

## **PUMP DOWN**

**This is performed when the unit is relocated or the refrigerant circuit is serviced.**

Pump Down means collecting all refrigerant into the outdoor unit without the loss of refrigerant.



**CAUTION: Be sure to perform Pump Down procedure in the cooling mode.**

### **Pump Down Procedure**

1. Connect a low-pressure gauge manifold hose to the charge port on the gas side service valve.
2. Open the gas side service valve halfway and purge the air in the manifold hose using the refrigerant.
3. Close the liquid side service valve(all the way).
4. Turn on the unit's operating switch and start the cooling operation.
5. When the low-pressure gauge reading becomes 1 to 0.5kg/cm<sup>2</sup> G(14.2 to 7.1 P.S.I.G.), fully close the gas side valve and then quickly turn off the unit. Now Pump Down procedure is completed, and all refrigerant is collected into the outdoor unit.

# Operation

## Function of Controls

### DISPLAY

#### 1) C/O Model (high quality LCD remote controller supplied)

##### Operation Indicator

- On while in appliance operation, off while in appliance pause

##### Timer Indicator

- On while in timer mode (on/off) and in sleep timer mode, off when timer mode is completed or canceled.

##### Comp. Running Indicator

- While in appliance operation, on while in outdoor unit compressor running, off while in compressor off

##### Auto restart Indicator

- On while auto restart mode, off while auto restart mode is canceled.

##### Auto restart

- In case the power comes on again after a power failure, Auto Restarting Operation is the function to operate procedures automatically to the previous operating conditions.  
If your want to use this operation, press the Auto Restart Button.

##### Power(Forced Operation)

- Operation starts, when this button is pressed and stops when you press the button again.

#### 2) H/P Model (high quality LCD remote controller supplied)

##### Operation Indicator

- On while in appliance operation, off while in appliance pause

##### Timer Indicator

- On while in timer mode (on/off) and in sleep timer mode, off when timer mode is completed or canceled

##### Defrost Indicator

- Off except when hot start during heating mode operation or while in defrost control.

##### Auto restart Indicator

- On while auto restart mode, off while auto restart mode is canceled.

##### Auto restart

- In case the power comes on again after a power failure, Auto Restarting Operation is the function to operate procedures automatically to the previous operating conditions.  
If your want to use this operation, press the Auto Restart Button.

##### Power(Forced Operation)

- Operation starts, when this button is pressed and stops when you press the button again.

### ■ Cooling Mode Operation

- When the intake air temperature reaches 0.5°C below the setting temp, the compressor and the outdoor fan stop.
- When it reaches 0.5°C above the setting temp, they start to operate again.  
Compressor ON Temp=> Setting Temp+0.5°C  
Compressor OFF Temp => Setting Temp-0.5°C
- While in compressor running, operating with the airflow speed set by the remote controller. While in compressor not running, operating with the low airflow speed regardless of the setting.

## ■ Healthy Dehumidification Mode

- When the dehumidification operation input by the remote controller is received, the intake air temperature is detected and the setting temp is automatically set according to the intake air temperature.
  - $26^{\circ}\text{C} \leq \text{Intake Air Temp} \Rightarrow 25^{\circ}\text{C}$
  - $24^{\circ}\text{C} \leq \text{Intake Air Temp} < 26^{\circ}\text{C} \Rightarrow \text{Intake Air Temp}-1^{\circ}\text{C}$
  - $18^{\circ}\text{C} \leq \text{Intake Air Temp} < 24^{\circ}\text{C} \Rightarrow \text{Intake Air Temp}-0.5^{\circ}\text{C}$
  - $\text{Intake Air Temp} < 18^{\circ}\text{C} \Rightarrow 18^{\circ}\text{C}$
- While in compressor off, the indoor fan repeats low airflow speed and pause.
- While the intake air temp is between compressor on temp. and compressor off temp., 10-min dehumidification operation and 4-min compressor off repeat
  - Compressor ON Temp.  $\Rightarrow$  Setting Temp $+0.5^{\circ}\text{C}$
  - Compressor OFF Temp.  $\Rightarrow$  Setting Temp $-0.5^{\circ}\text{C}$
- In 10-min dehumidification operation, the indoor fan operates with the low airflow speed.

## ■ Heating Mode Operation

- When the intake air temp reaches  $+3^{\circ}\text{C}$  above the setting temp, the compressor is turned off. When below the setting temp, the compressor is turned on.
  - Compressor ON Temp.  $\Rightarrow$  Setting Temp.
  - Compressor OFF Temp.  $\Rightarrow$  Setting Temp. $+3^{\circ}\text{C}$
- While in compressor on, the indoor fan is off when the indoor pipe temp. is below  $26^{\circ}\text{C}$ , when above  $28^{\circ}\text{C}$ , it operates with the low or setting airflow speed (while in sleep mode, with the medium airflow speed).
- While in compressor off, the indoor fan is off when the indoor pipe temp is below  $33^{\circ}\text{C}$ , when above  $35^{\circ}\text{C}$ , it operates with the low airflow speed.
- If overloaded while in heating mode operation, in order to prevent the compressor from OLP operation, the outdoor fan is turned on/off according to the indoor pipe temp.
- While in defrost control, both of the indoor and outdoor fans are turned off.

## ■ Defrost Control

- While in heating mode operation in order to protect the evaporator pipe of outdoor unit from freezing, reversed to cooling cycle to defrost the evaporator pipe of the outdoor unit.
- Defrost control is available 30 minutes later since heating mode operation started, and it will not prolong over 6 minutes.
- Deicing starts only when the outdoor pipe temperature falls below  $-6^{\circ}\text{C}$  after 30 minutes passed from starting of heating operating and more than 10 minutes operation of compressor.
- Deicing ends after 6 minutes passed from starting of deice operation or when the outdoor pipe temperature rises over  $12^{\circ}\text{C}$  even if before 6 minutes.

## ■ Fuzzy Operation (C/O Model)

- According to the temperature set by Fuzzy rule, when the intake air temp is  $0.5^{\circ}\text{C}$  or more below the setting temp, the compressor is turned off. When  $0.5^{\circ}\text{C}$  or more above the setting temp, the compressor is turned on.
  - Compressor ON Temp  $\Rightarrow$  Setting Temp $+0.5^{\circ}\text{C}$
  - Compressor OFF Temp  $\Rightarrow$  Setting Temp $+0.5^{\circ}\text{C}$
- At the beginning of Fuzzy mode operation, the setting temperature is automatically selected according to the intake air temp at that time.

$26^{\circ}\text{C} \leq \text{Intake Air Temp} \Rightarrow 25^{\circ}\text{C}$   
 $24^{\circ}\text{C} \leq \text{Intake Air Temp} < 26^{\circ}\text{C} \Rightarrow \text{Intake Air Temp} + 1^{\circ}\text{C}$   
 $22^{\circ}\text{C} \leq \text{Intake Air Temp} < 24^{\circ}\text{C} \Rightarrow \text{Intake Air Temp} + 0.5^{\circ}\text{C}$   
 $18^{\circ}\text{C} \leq \text{Intake Air Temp} < 22^{\circ}\text{C} \Rightarrow \text{Intake Air Temp}$   
 $\text{Intake Air Temp} < 18^{\circ}\text{C} \Rightarrow 18^{\circ}\text{C}$

- When the Fuzzy key (Temperature Control key) is input after the initial setting temperature is selected, the Fuzzy key value and the intake air temperature at that time are compared to select the setting temperature automatically according to the Fuzzy rule.
- While in Fuzzy operation, the airflow speed of the indoor fan is automatically selected according to the temperature

### ■ Fuzzy Operation (H/P Model)

- When any of operation mode is not selected like the moment of the power on or when 3 hrs has passed since the operation off, the operation mode is selected.
- When determining the operation mode, the compressor, the outdoor fan, and the 4 way valve are off and only the indoor fan is operated for 15 seconds. Then an operation mode is selected according to the intake air temp at that moment as follows.  
 $24^{\circ}\text{C} \leq \text{Intake Air Temp} \Rightarrow \text{Fuzzy Operation for Cooling}$   
 $21^{\circ}\text{C} \leq \text{Intake Air Temp} < 24^{\circ}\text{C} \Rightarrow \text{Fuzzy Operation for Dehumidification}$   
 $\text{Intake Air Temp} < 21^{\circ}\text{C} \Rightarrow \text{Fuzzy Operation for Heating}$
- If any of the operation modes among cooling / dehumidification / heating mode operations is carried out for 10 sec or longer before Fuzzy operation, the mode before Fuzzy operation is operated.

#### 1) Fuzzy Operation for Cooling

- According to the setting temperature selected by Fuzzy rule, when the intake air temp is  $0.5^{\circ}\text{C}$  or more below the setting temp, the compressor is turned off. When  $0.5^{\circ}\text{C}$  or more above the setting temp, the compressor is turned on.  
Compressor ON Temp  $\Rightarrow \text{Setting Temp} + 0.5^{\circ}\text{C}$   
Compressor OFF Temp  $\Rightarrow \text{Setting Temp} + 0.5^{\circ}\text{C}$
- At the beginning of Fuzzy mode operation, the setting temperature is automatically selected according to the intake air temp at that time.  
 $26^{\circ}\text{C} \leq \text{Intake Air Temp} \Rightarrow 25^{\circ}\text{C}$   
 $24^{\circ}\text{C} \leq \text{Intake Air Temp} < 26^{\circ}\text{C} \Rightarrow \text{Intake Air Temp} + 1^{\circ}\text{C}$   
 $22^{\circ}\text{C} \leq \text{Intake Air Temp} < 24^{\circ}\text{C} \Rightarrow \text{Intake Air Temp} + 0.5^{\circ}\text{C}$   
 $18^{\circ}\text{C} \leq \text{Intake Air Temp} < 22^{\circ}\text{C} \Rightarrow \text{Intake Air Temp}$   
 $\text{Intake Air Temp} < 18^{\circ}\text{C} \Rightarrow 18^{\circ}\text{C}$
- When the Fuzzy key (Temperature Control key) is input after the initial setting temperature is selected, the Fuzzy key value and the intake air temperature at that time are compared to select the setting temperature automatically according to the Fuzzy rule.
- While in Fuzzy operation, the airflow speed of the indoor fan is automatically selected according to the temperature.

#### 2) Fuzzy Operation for Dehumidification

- According to the setting temperature selected by Fuzzy rule, when the intake air temp is  $0.5^{\circ}\text{C}$  or more below the setting temp, the compressor is turned off. When  $0.5^{\circ}\text{C}$  or more above the setting temp, the compressor is turned on.  
Compressor ON Temp  $\Rightarrow \text{Setting Temp} + 0.5^{\circ}\text{C}$   
Compressor OFF Temp  $\Rightarrow \text{Setting Temp} + 0.5^{\circ}\text{C}$

- At the beginning of Fuzzy mode operation, the setting temperature is automatically selected according to the intake air temp at that time.

$26^{\circ}\text{C} \leq \text{Intake Air Temp} \Rightarrow 25^{\circ}\text{C}$

$24^{\circ}\text{C} \leq \text{Intake Air Temp} < 26^{\circ}\text{C} \Rightarrow \text{Intake Air Temp} + 1^{\circ}\text{C}$

$22^{\circ}\text{C} \leq \text{Intake Air Temp} < 24^{\circ}\text{C} \Rightarrow \text{Intake Air Temp} + 0.5^{\circ}\text{C}$

$18^{\circ}\text{C} \leq \text{Intake Air Temp} < 22^{\circ}\text{C} \Rightarrow \text{Intake Air Temp}$

$\text{Intake Air Temp} < 18^{\circ}\text{C} \Rightarrow 18^{\circ}\text{C}$

- When the Fuzzy key (Temperature Control key) is input after the initial setting temperature is selected, the Fuzzy key value and the intake air temperature at that time are compared to select the setting temperature automatically according to the Fuzzy rule.
- While in Fuzzy operation, the airflow speed of the indoor fan repeats the low airflow speed or pause as in dehumidification operation.

### 3) Fuzzy Operation for Heating

- According to the setting temperature selected by Fuzzy rule, when the intake air temp is  $3^{\circ}\text{C}$  or more above the setting temp, the compressor is turned off. When below the setting temp, the compressor is turned on.

Compressor ON Temp  $\Rightarrow$  Setting Temp

Compressor OFF Temp  $\Rightarrow$  Setting Temp +  $3^{\circ}\text{C}$

- At the beginning of Fuzzy mode operation, the setting temperature is automatically selected according to the intake air temp at that time.

$20^{\circ}\text{C} \leq \text{Intake Air Temp} \Rightarrow \text{Intake Air Temp} + 0.5^{\circ}\text{C}$

$\text{Intake Air Temp} < 20^{\circ}\text{C} \Rightarrow 20^{\circ}\text{C}$

- When the Fuzzy key (Temperature Control key) is input after the initial setting temperature is selected, the Fuzzy key value and the intake air temperature at that time are compared to select the setting temperature automatically according to the Fuzzy rule.
- While in Fuzzy operation, the airflow speed of the indoor fan is set to the high or the medium according to the intake air temperature and the setting temperature.

#### ■ Airflow Speed Selection

- The airflow speed of the indoor fan is set to high, medium, low, or chaos by the input of the airflow speed selection key on the remote controller.

#### ■ On-Timer Operation

- When the set time is reached after the time is input by the remote controller, the appliance starts to operate.
- The timer LED is on when the on-timer is input. It is off when the time set by the timer is reached.
- If the appliance is operating at the time set by the timer, the operation continues.

#### ■ Off-Timer Operation

- When the set time is reached after the time is input by the remote controller, the appliance stops operating.
- The timer LED is on when the off-timer is input. It is off when the time set by the timer is reached.
- If the appliance is on pause at the time set by the timer, the pause continues.

### ■ Off-Timer <=> On-Timer Operation

- When the set time is reached after the on/off time is input by the remote controller, the on/off-timer operation is carried out according to the set time.

### ■ Sleep Timer Operation

- When the sleep time is reached after <1,2,3,4,5,6,7,0(cancel) hr> is input by the remote controller while in appliance operation, the operation of the appliance stops.
- While the appliance is on pause, the sleep timer mode cannot be input.
- While in cooling mode operation, 30 min later since the start of the sleep timer, the setting temperature increases by 1°C. After another 30 min elapse, it increases by 1°C again.
- When the sleep timer mode is input while in cooling cycle mode, the airflow speed of the indoor fan is set to the low.
- When the sleep timer mode is input while in heating cycle mode, the airflow speed of the indoor fan is set to the medium.

### ■ Chaos Swing Mode

- By the Chaos Swing key input, the vane automatically operates with the Chaos Swing or they are fixed to the desired direction.

### ■ Chaos Natural Wind Mode

- When the Chaos Natural Wind mode is selected and then operated, the high, medium, or low speed of the airflow mode is operated for 2~15 sec randomly by the Chaos Simulation.”

### ■ Jet Cool Mode Operation (C/O Model)

- If the Jet Cool key is input at any operation mode while in appliance operation, the Jet Cool mode operates.
- In the Jet Cool mode, the indoor fan is operated at super-high speed for 30 min at cooling mode operation.
- In the Jet Cool mode operation, the room temperature is controlled to the setting temperature, 18°C
- When the sleep timer mode is input while in the Jet Cool mode operation, the Jet Cool mode has the priority.
- During the JET COOL function at any moment, the A/C starts to blow the cool air with side louvers closed at extremely high speed for 30 minutes setting the room temp. automatically to 18°C.

### ■ Jet Cool Mode Operation (H/P Model)

- While in heating mode or Fuzzy operation, the Jet Cool key cannot be input. When it is input while in the other mode operation (cooling, dehumidification, ventilation), the Jet Cool mode is operated.”
- In the Jet Cool mode, the indoor fan is operated at super-high speed for 30 min at cooling mode operation.
- In the Jet Cool mode operation, the room temperature is controlled to the setting temperature, 18°C
- When the sleep timer mode is input while in the Jet Cool mode operation, the Jet Cool mode has the priority.
- During the JET HEAT function at any moment, the A/C starts to blow the hot air with side louvers closed at extremely high speed for 60 minutes setting the room temp. automatically to 30°C.

### ■ Auto Restarting Operation

- When the power is restored after a sudden power failure while in appliance operation, the mode before the power failure is kept on the memory and the appliance automatically operates in the mode on the memory.
- Operation Mode that is kept on the memory
  - State of Operation ON/OFF

- Operation Mode/Setting Temp/Selected Airflow Speed
- Sleep Timer Mode/Remaining Time of Sleep Timer (unit of hour)

### ■ Forced Operation

- Operation procedures when the remote control can't be used.
- The operation will be started if the power button is pressed.
- If you want to stop operation, re-press the button.

	Cooling Model	Heat pump Model		
		Room Temp. $\geq 24^{\circ}\text{C}$	$21^{\circ}\text{C} \leq \text{Room Temp.} < 24^{\circ}\text{C}$	Room Temp. $< 21^{\circ}\text{C}$
Operating mode	Cooling	Cooling	Healthy Dehumidification	Heating
Indoor Fan Speed	High	High	High	High
Setting Temperature	22°C	22°C	23°C	24°C

- While in forced operation, the key input by the remote control has no effect and the buzzer sounds 10 times to indicate the forced operation.

### ■ Test operation

- During the TEST OPERATION, the unit operates in cooling mode at high speed fan, regardless of room temperature and resets in 18±1 minutes.
- During test operation, if remote controller signal is received, the unit operates as remote controller sets. If you want to use this operation, open the front panel upward and Press the power button let it be pressed for about 3 seconds.
- If you want to stop the operation, re-press the button.

### ■ Protection of the evaporator pipe from frosting

- If the indoor pipe temp is below 0°C in 7 min. after the compressor operates without any pause while in cooling cycle operation mode, the compressor and the outdoor fan are turned off in order to protect the indoor evaporator pipe from frosting.
- When the indoor pipe temp is 7°C or higher after 3 min. pause of the compressor, the compressor and the outdoor fan is turned on according to the condition of the room temperature.

### ■ Buzzer Sounding Operation

- When the appliance-operation key is input by the remote control, the short "beep-beep-" sounds.
- When the appliance-pause key is input by the remote control, the long "beep—" sounds.
- When a key is input by the remote control while the slide switch on the main unit of the appliance is on the forced operation position, the error sound "beep-beep-beep-beep-beep-" is made 10 times to indicate that the remote control signal cannot be received.

### ■ Air Cleaner Operation

- When an air cleaner function is selected during Air Conditioner operation
  - The function is to be stopped while it is operating with selecting the function.
- When an air cleaner function is selected during operation off
  - The function will be only operated.

## Display Function

### 1. Heating Model

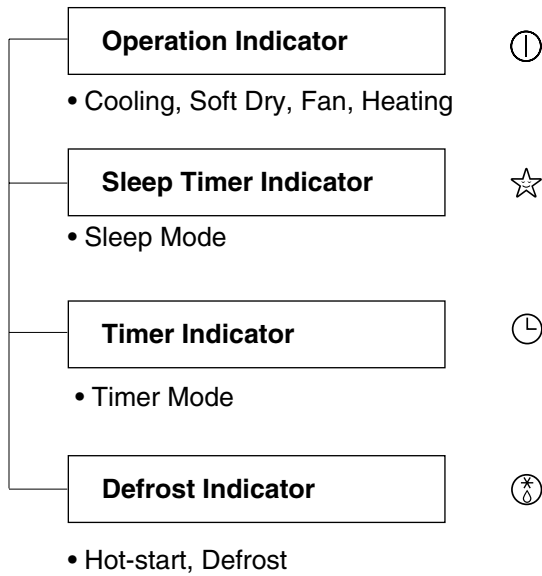

### 2. Cooling Model

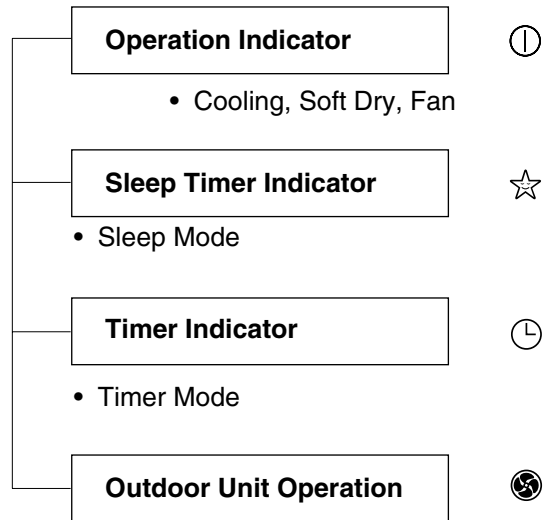

## Self-diagnosis Function

Error Code	Error Display LED (Indoor body operation LED)	Error contents	SVC check point
1	<p>(once)</p> <p>3sec 3sec 3sec</p>	<ul style="list-style-type: none"> <li>Indoor room temperature thermistor open/short</li> <li>Indoor pipe temperature thermistor open/short.</li> </ul>	<ul style="list-style-type: none"> <li>Indoor Thermistor assembly check</li> </ul>

## Remote Control Operations

The controls will look like the following.

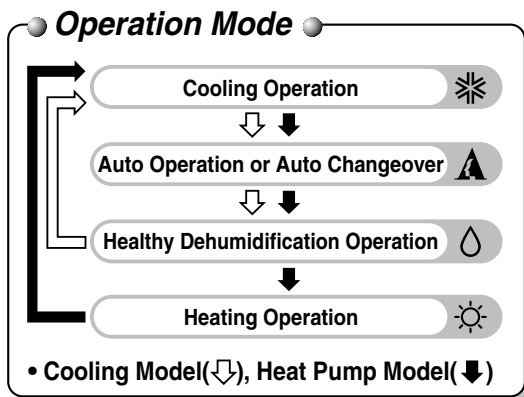
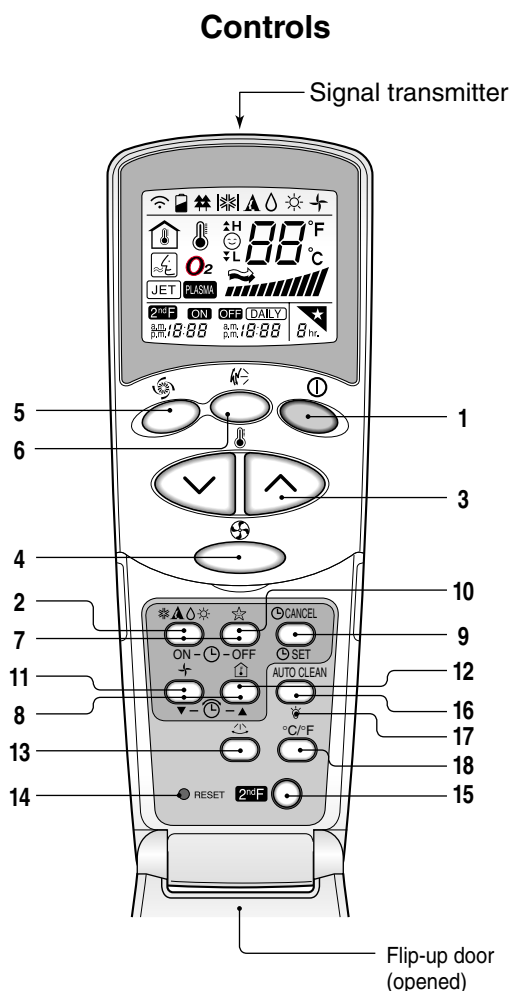

### 1. START/STOP BUTTON

Operation starts when this button is pressed and stops when the button is pressed again.



### 2. OPERATION MODE SELECTION BUTTON

Used to select the operation mode.



### 3. ROOM TEMPERATURE SETTING BUTTONS

Used to select the room temperature.



### 4. INDOOR FAN SPEED SELECTOR

Used to select fan speed in four steps low, medium, high and CHAOS.



### 5. JET COOL

Used to start or stop the speed cooling.(speed cooling operates super high fan speed in cooling mode.)



### 6. CHAOS SWING BUTTON

Used to stop or start louver movement and set the desired up/down airflow direction.



### 7. ON/OFF TIMER BUTTONS

Used to set the time of starting and stopping operation.

### 8. TIME SETTING BUTTONS

Used to adjust the time.

### 9. TIMER SET/CANCEL BUTTON

Used to set the timer when the desired time is obtained and to cancel the Timer operation.

### 10. SLEEP MODE AUTO BUTTON

Used to set Sleep Mode Auto operation.

### 11. AIR CIRCULATION BUTTON

Used to circulate the room air without cooling or heating.

### 12. ROOM TEMPERATURE CHECKING BUTTON

Used to check the room temperature.

### 13. HORIZONTAL AIRFLOW DIRECTION CONTROL BUTTON (OPTIONAL)

Used to set the desired horizontal airflow direction.

### 14. RESET BUTTON

Used prior to resetting time.

### 15. 2nd F Button

Used prior to using modes printed in blue at the bottom of buttons.

### 16. AUTO CLEAN (OPTIONAL)

Used to set Auto Clean mode.

### 17. LED LUMINOSITY (OPTIONAL)

Used to adjust LED luminosity.

### 18. °C/°F SWITCH BUTTON

Used to switch temperature reading from Centigrade to Fahrenheit.

# Disassembly

## Indoor Unit

**⚠ WARNING:** Disconnect the unit from power supply before making any checks. Be sure the power switch is set to "OFF"

### To remove the Grille from the Chassis.

- Hold up Inlet Grille Horizontally.
- To remove the Grille, pull the lower left and right side of the grille toward you (slightly tilted) and lift it straight upward.
- To separate connector assembly and then to remove Inlet Grille assembly.

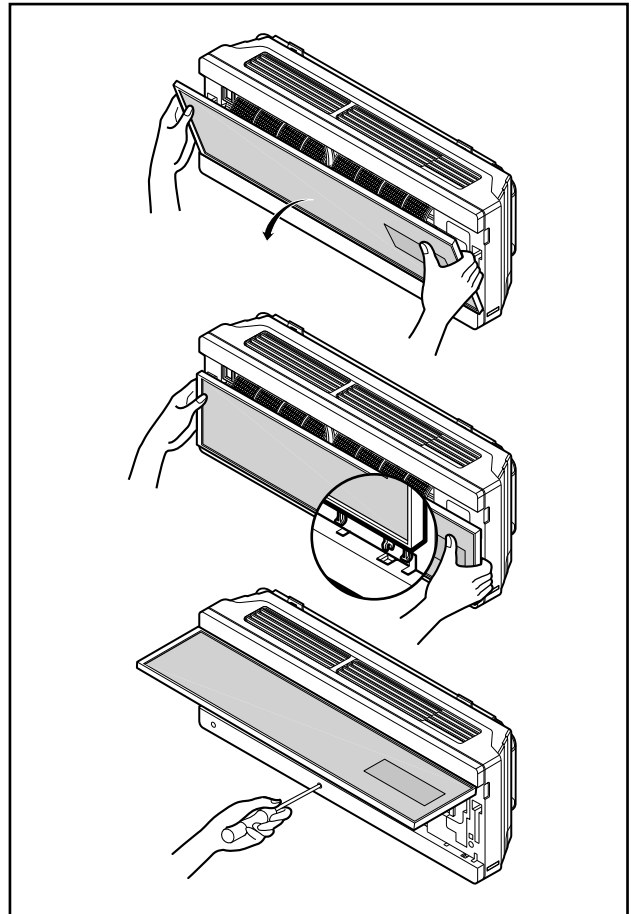

1. Before removing the control box, be sure to take out the wire screwed at the other end.

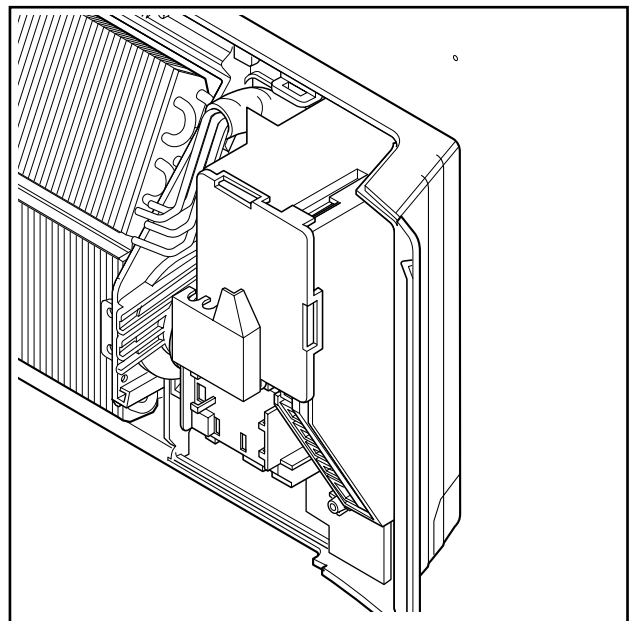

**2. To remove the Control Box.**

- Remove securing screws.
- Pull the control box out from the chassis carefully.

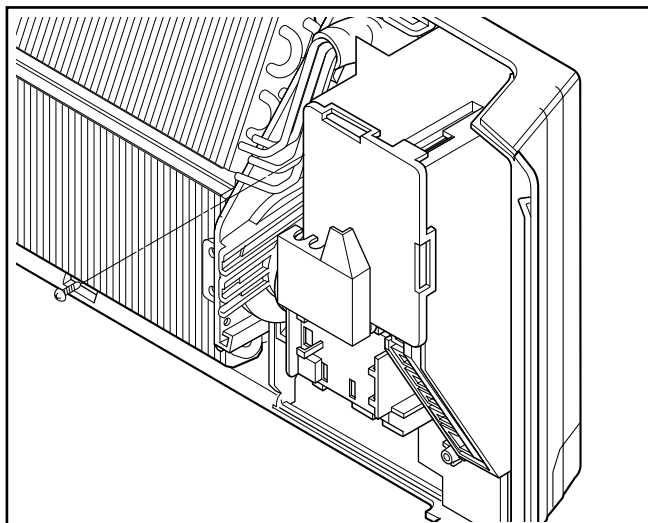
**3. To remove the Discharge Grille.**

- Unhook the discharge grille and pull the discharge grille out from the chassis carefully.

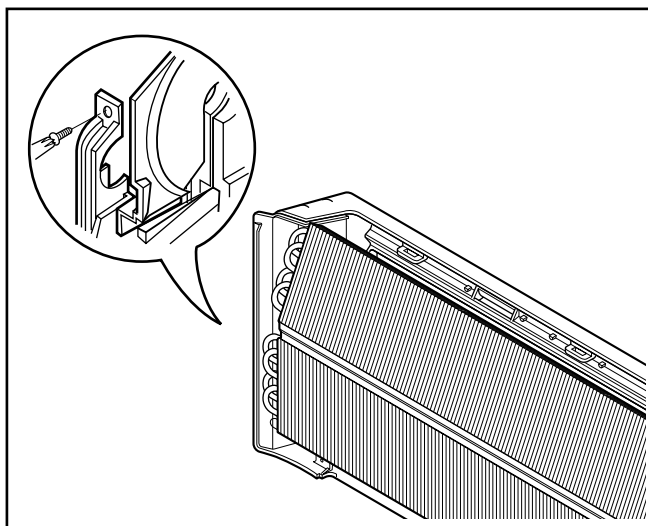
**4. To remove the Evaporator.**

- Remove 3 screws securing the evaporator(at the left 2EA in the Eva Holder, at the right 1EA).

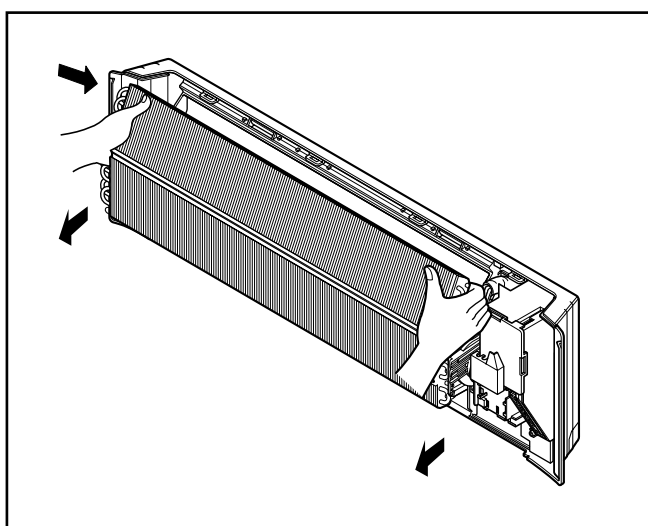

- Unhook the tab on the right inside of the chassis at the same time, slightly pull the evaporator toward you until the tab is clear of the slot.

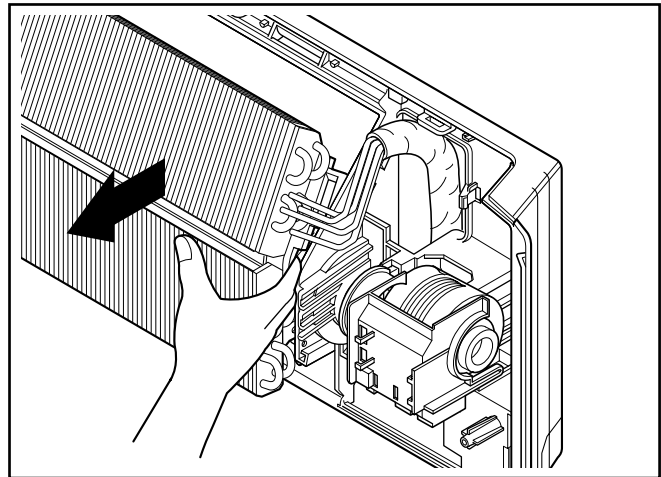

**5. To remove the Motor Cover**

- Remove 2 securing screw.
- Pull the motor cover out from the chassis carefully.

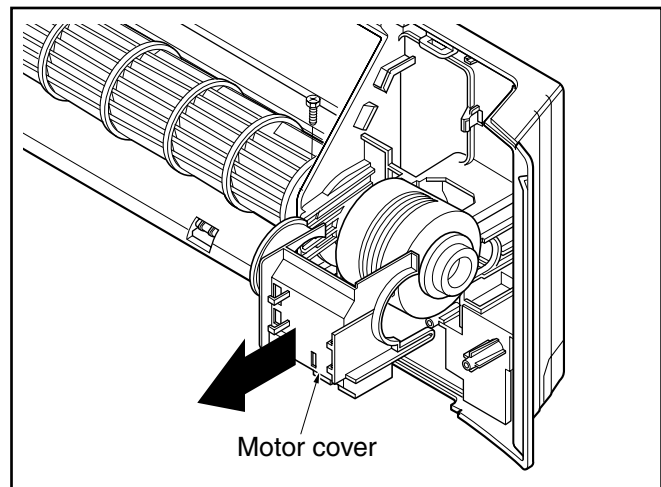

**6. To remove the Cross-Flow Fan**

- Loosen the screw securing the cross-flow fan to the fan motor (do not remove).
- Lift up the right side of the cross-flow fan and the fan motor, separate the fan motor from the cross-flow fan.

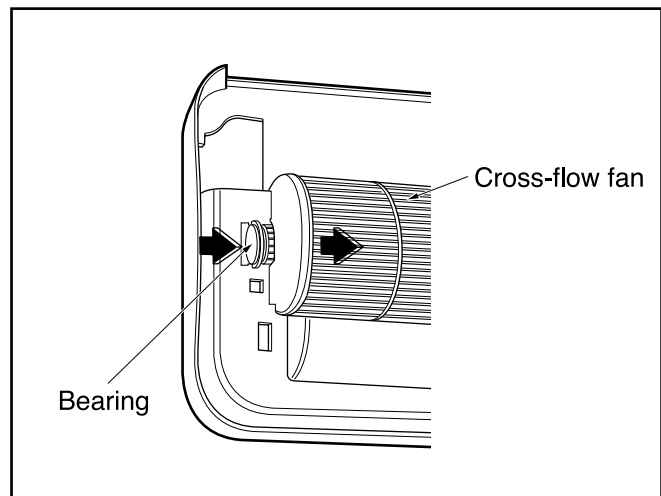

- Remove the left end of the cross-flow fan from the self-aligning bearing.

# Schematic Diagram

## Electric Control Device

### 1. Indoor Unit

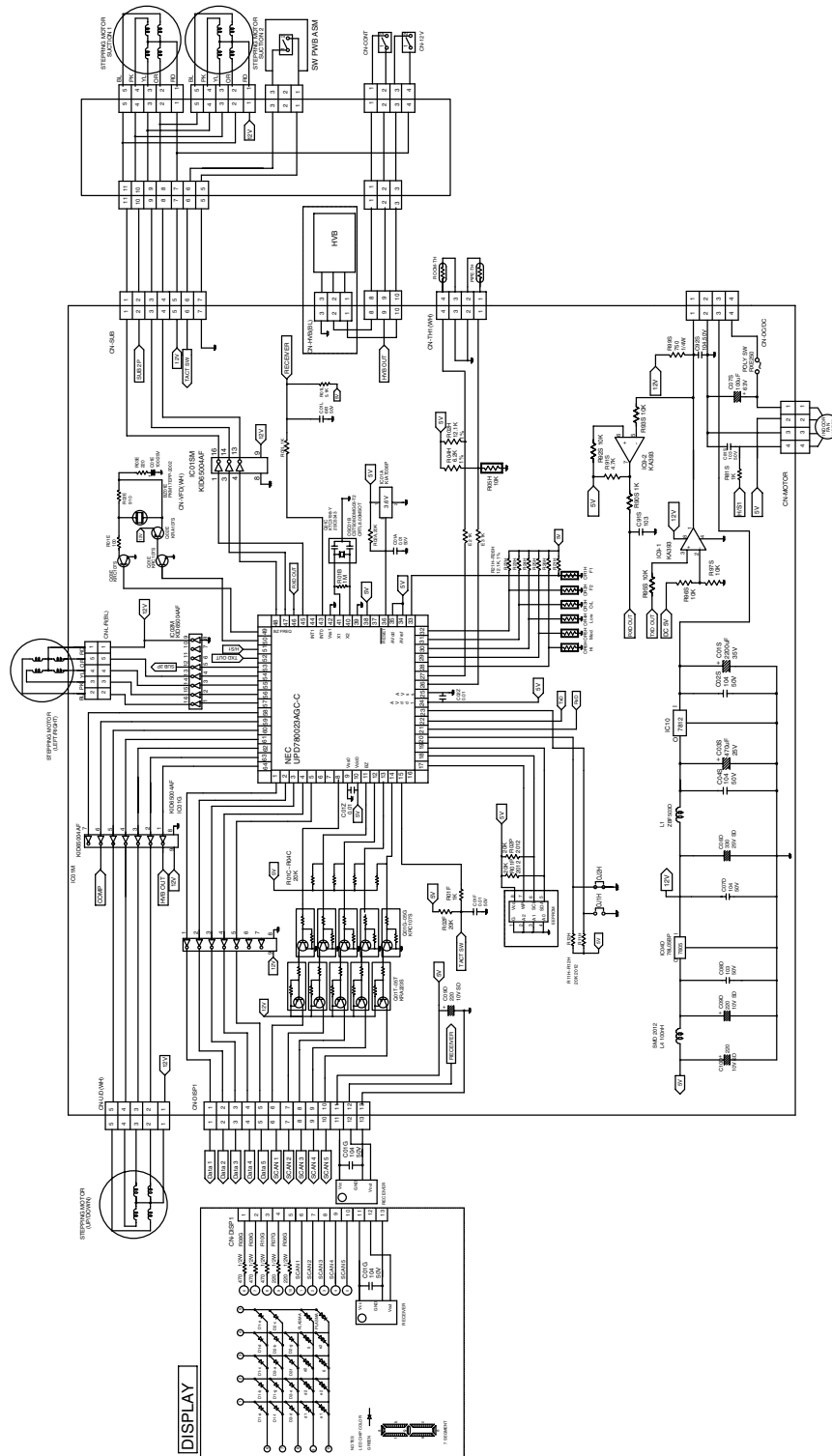



# Wiring Diagram

## Indoor Unit

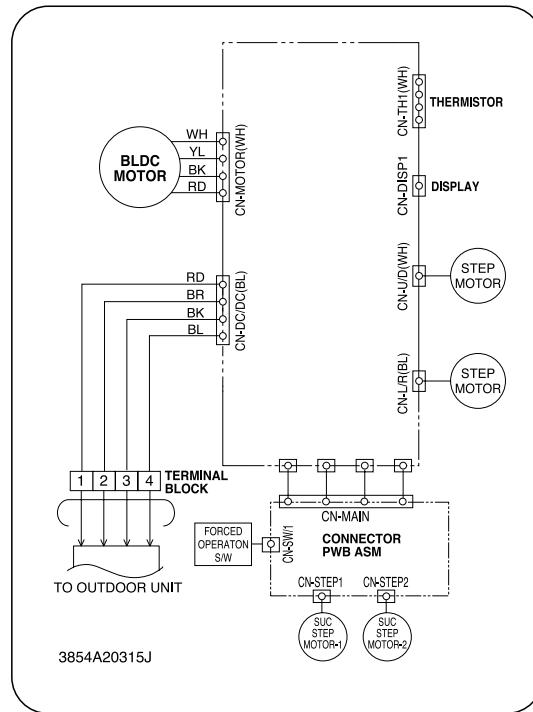

## Outdoor Unit

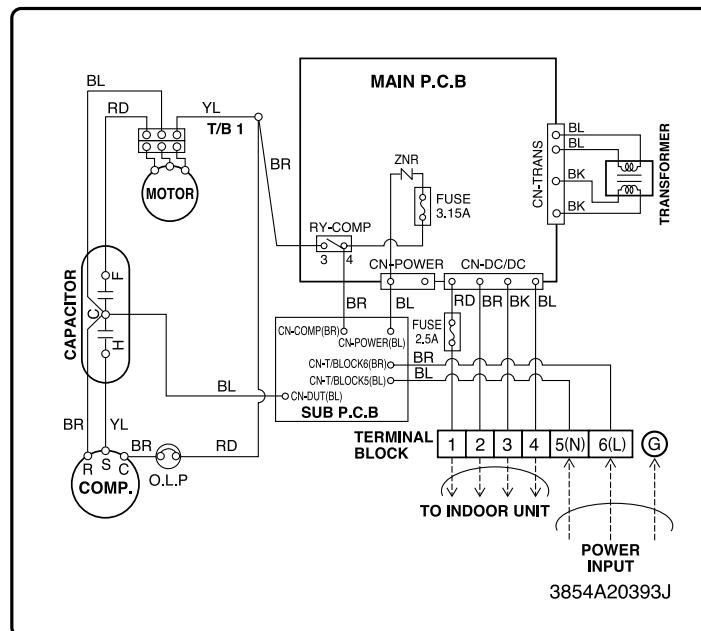

**Components Location**

**MAIN P.W.B ASSEMBLY (Indoor)**

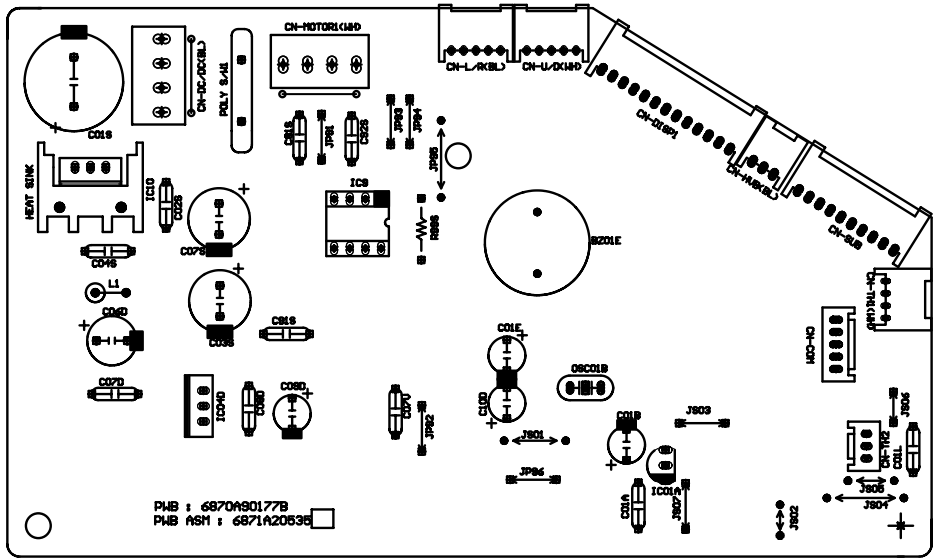

**• PWB ASSY SVC PART LIST**

NO	MODEL	P/No.	OPTIONAL FUNCTION					
			OR1H	OR2H	OR3H	OR4H	OR5H	OR6H
1	14K Cooling Model	6871A20535A	12K	5.1K	200K	OPEN	OPEN	OPEN

OJ1H, OJ2H: OPEN

# MAIN P.W.B ASSEMBLY (Outdoor)

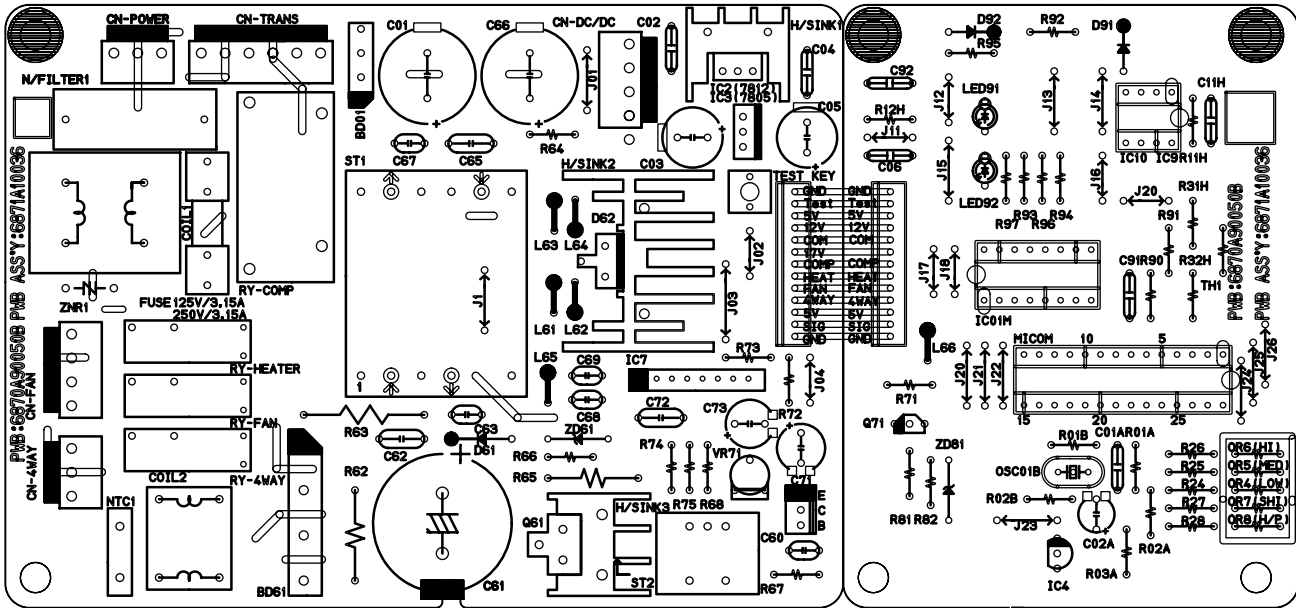

## • PWB ASSY SVC PART LIST

NO	MODEL	P/No.	OPTIONAL FUNCTION												
			OR4H	OR5H	OR6H	OR7H	OR 8H	FUSE	RY-HEATER	RY-4WAY	RY-FAN	CN-4WAY	CN-FAN	CN-TH	
1	14K Cooling Model	6871A10036N	10K	32K	20K	20K	13K	125V 3.15A	X	X	X	X	X	X	

# DISPLAY ASSEMBLY

- 6871A20462  
TOP VIEW

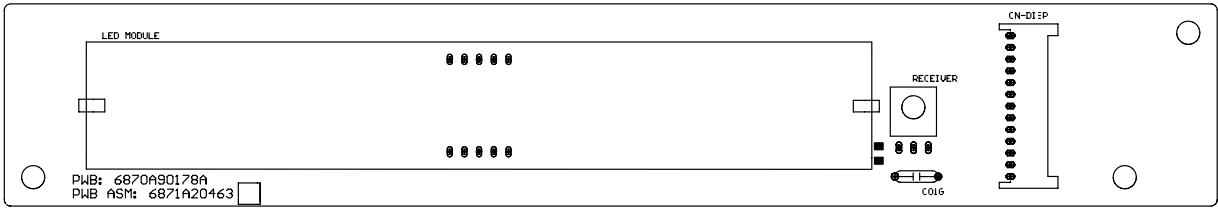

BOTTOM VIEW

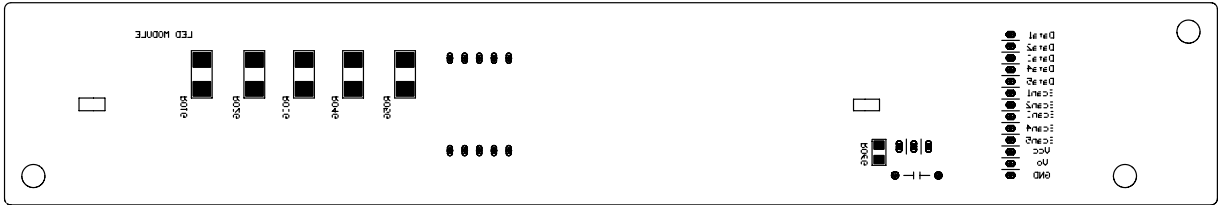

# SUB P.W.B ASSEMBLY

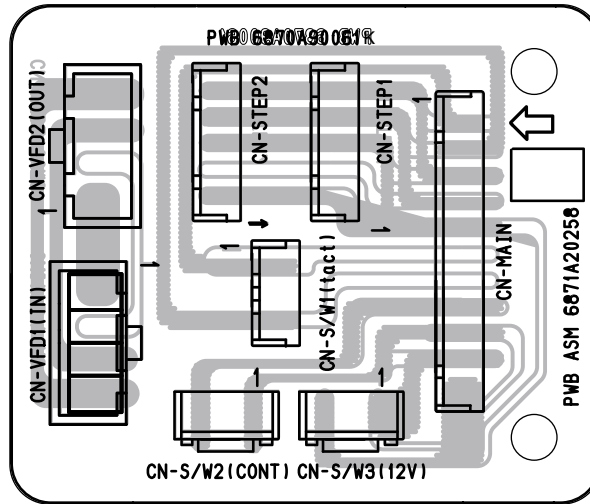

• VOLTAGE OF CONNECTORS ACCORDING TO INDOOR FAN SPEED

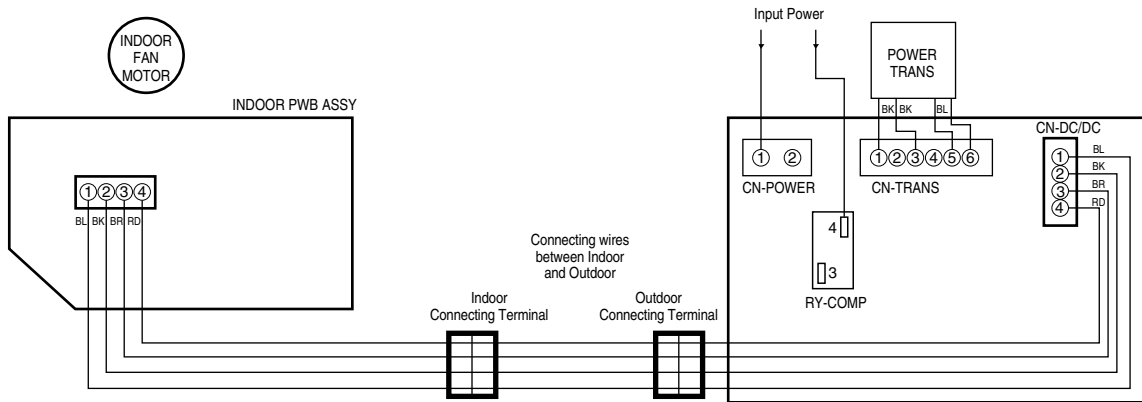

MODELS	No. of pins		14K				
			DC Voltage(±10%)				
CONNELTORS	+	-	S-Hi	Hi	Med	Low	Off
INDOOR CN- MOTOR	1	3	34.1	30.4	24.1	20.0	0.0
	2	3	5.0	5.0	5.0	5.0	5.0
	4	3	0~5	0~5	0~5	0~5	5.0
INDOOR CN- DC/DC	1	2	0~12	0~12	0~12	0~12	0~12
	3	2	17.0	17.0	17.0	17.0	17.0
	4	2	34.1	30.4	24.1	20.0	0.0
OUTDOO R CN- DC/DC	1	2	0~12	0~12	0~12	0~12	0~12
	3	2	17.0	17.0	17.0	17.0	17.0
	4	2	34.1	30.4	24.1	20.0	0.0

# Troubleshooting Guide

## Refrigeration Cycle Diagram

### (1) Cooling Only Models

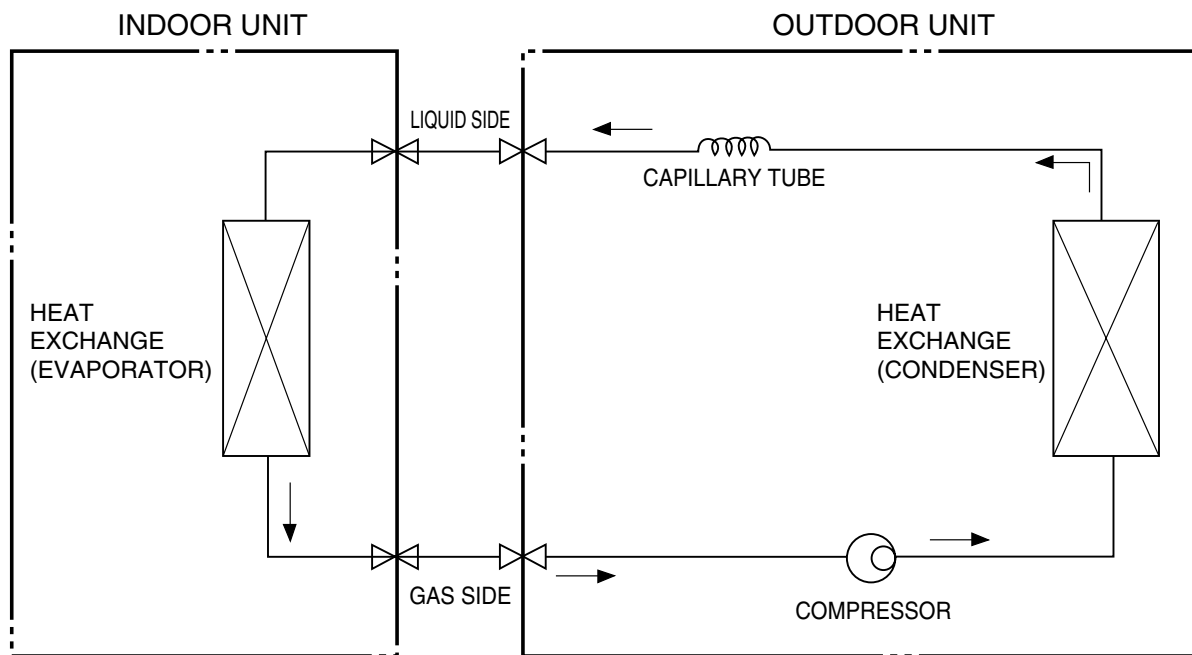

### (2) Cooling & Heating Models

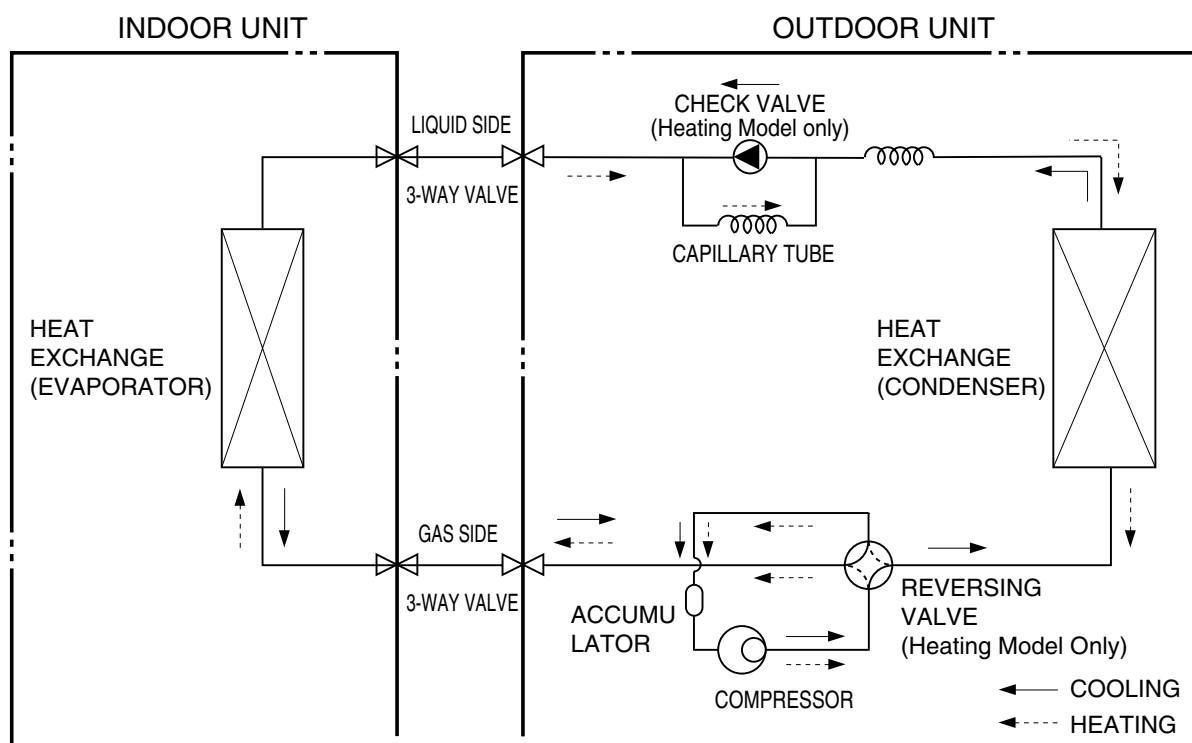

## 2-way, 3-way Valve

		2-way Valve (Liquid Side)	3-way Valve (Gas Side)	
Works		Shaft position	Shaft position	Service port
Shipping		Closed (with valve cap)	Closed (with valve cap)	Closed (with cap)
1.	Air purging (Installation)	Open (counter-clockwise)	Closed (clockwise)	Open (push-pin or with vacuum pump)
Operation		Open (with valve cap)	Open (with valve cap)	Closed (with cap)
2.	Pumping down (Transferring)	Closed (clockwise)	Open (counter-clockwise)	Open (connected manifold gauge)
3.	Evacuation (Servicing)	Open	Open	Open (with charging cylinder)
4.	Gas charging (Servicing)	Open	Open	Open (with charging cylinder)
5.	Pressure check (Servicing)	Open	Open	Open (with charging cylinder)
6.	Gas releasing (Servicing)	Open	Open	Open (with charging cylinder)

## Pumping Down

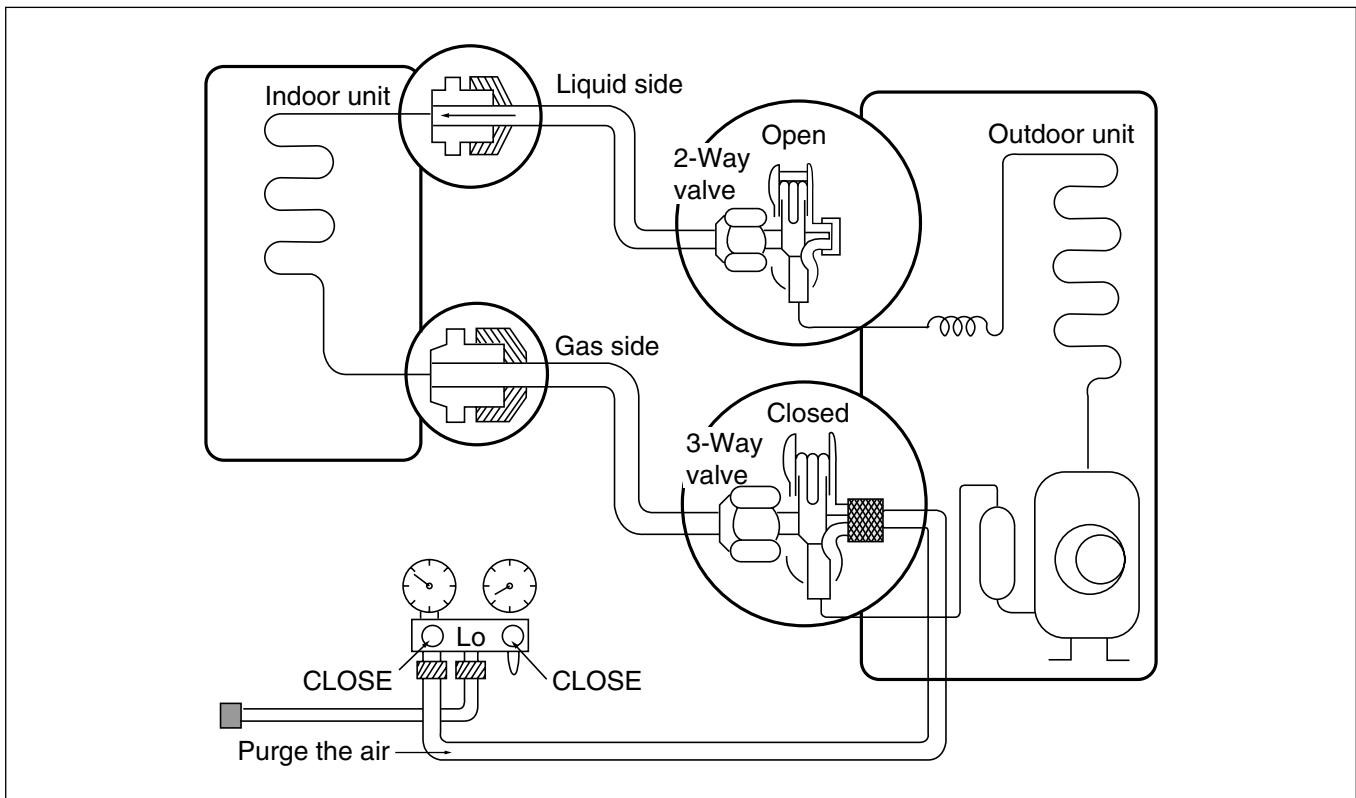

### • Procedure

- (1) **Confirm that both the 2-way and 3-way valves are set to the open position.**
  - Remove the valve stem caps and confirm that the valve stems are in the raised position.
  - Be sure to use a hexagonal wrench to operate the valve stems.
- (2) **Operate the unit for 10 to 15 minutes.**
- (3) **Stop operation and wait for 3 minutes, then connect the charge set to the service port of the 3-way valve.**
  - Connect the charge hose with the push pin to the service port.
- (4) **Air purging of the charge hose.**
  - Open the low-pressure valve on the charge set slightly to air purge from the charge hose.
- (5) **Set the 2-way valve to the closed position.**
- (6) **Operate the air conditioner at the cooling cycle and stop it when the gauge indicates 1kg/cm<sup>2</sup>g.**
- (7) **Immediately set the 3-way valve to the closed position.**
  - Do this quickly so that the gauge ends up indicating 3 to 5kg/cm<sup>2</sup>g.
- (8) **Disconnect the charge set, and mount the 2-way and 3-way valve's stem nuts and the service port nut.**
  - Use torque wrench to tighten the service port nut to a torque of 1.8 kg.m.
  - Be sure to check for gas leakage.

## Balance Refrigerant of the 3-way Valve

(Gas leakage)

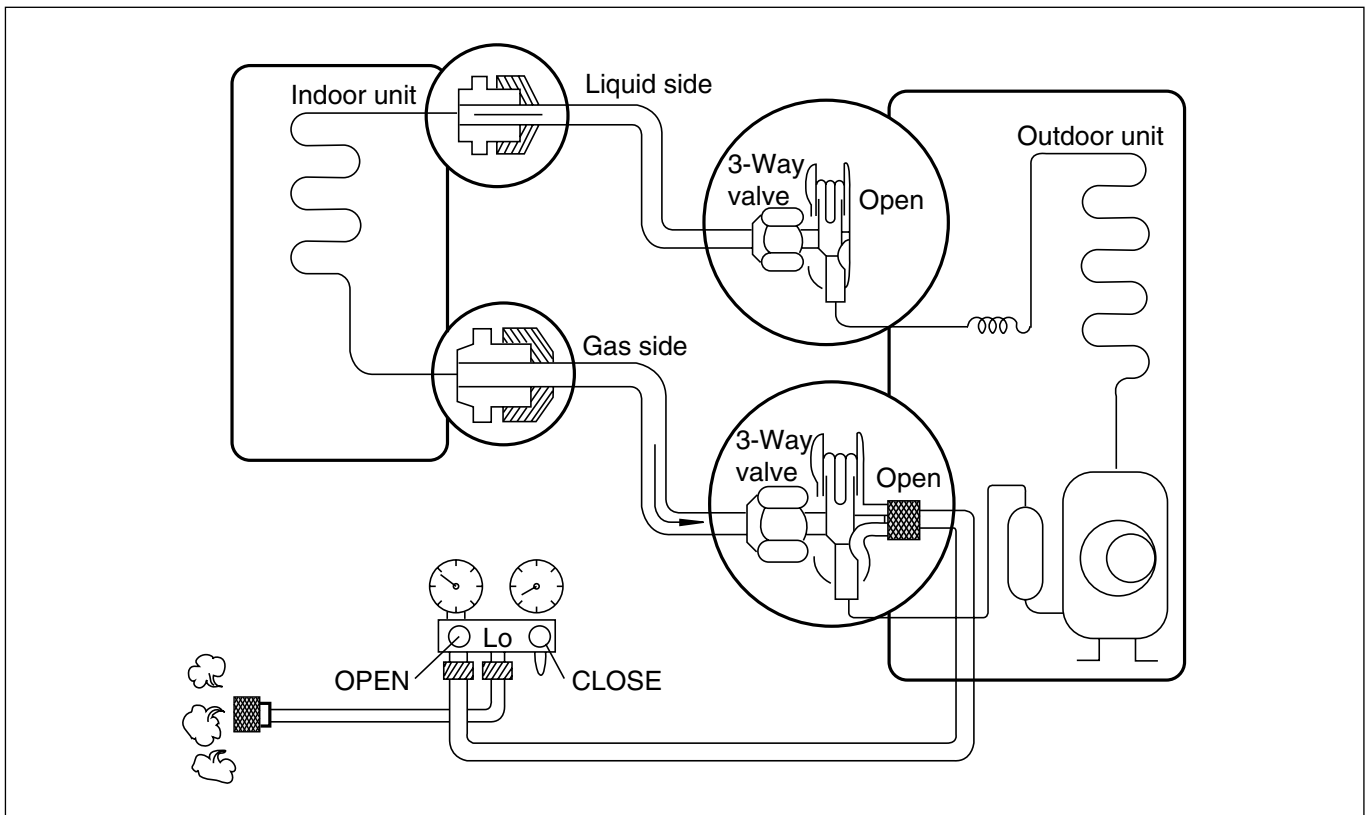

### • Procedure

- (1) Confirm that both the 2-way and 3-way valves are set to the back seat.
- (2) Connect the charge set to the 3-way valve's port.
  - Leave the valve on the charge set closed.
  - Connect the charge hose to the service port.
- (3) Open the valve (Lo side) on the charge set and discharge the refrigerant until the gauge indicates 0 kg/cm<sup>2</sup>G.
  - If there is no air in the refrigerant cycle (the pressure when the air conditioner is not running is higher than 1 kg/cm<sup>2</sup>G), discharge the refrigerant until the gauge indicates 0.5 to 1 kg/cm<sup>2</sup>G. If this is the case, it will not be necessary to apply a vacuum.
  - Discharge the refrigerant gradually; if it is discharged too suddenly, the refrigeration oil will also be discharged.

## Evacuation

(All amount of refrigerant leaked)

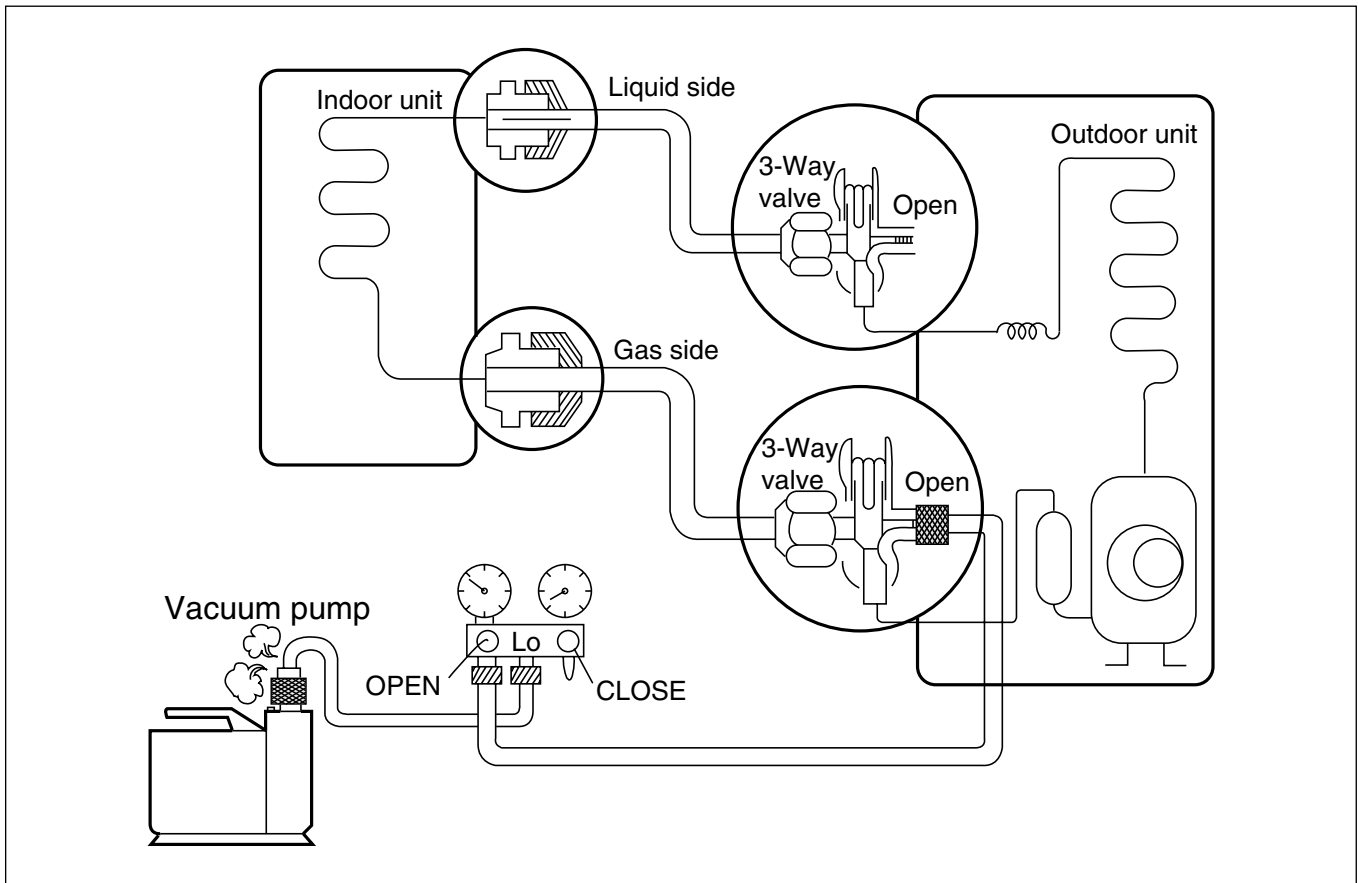

### • Procedure

- (1) Connect the vacuum pump to the center hose of charge set center hose
- (2) Evacuation for approximately one hour.
  - Confirm that the gauge needle has moved toward -76 cmHg (vacuum of 4 mmHg or less).
- (3) Close the valve (Lo side) on the charge set, turn off the vacuum pump, and confirm that the gauge needle does not move (approximately 5 minutes after turning off the vacuum pump).
- (4) Disconnect the charge hose from the vacuum pump.
  - Vacuum pump oil.  
If the vacuum pump oil becomes dirty or depleted, replenish as needed.

## Gas Charging

(After Evacuation)

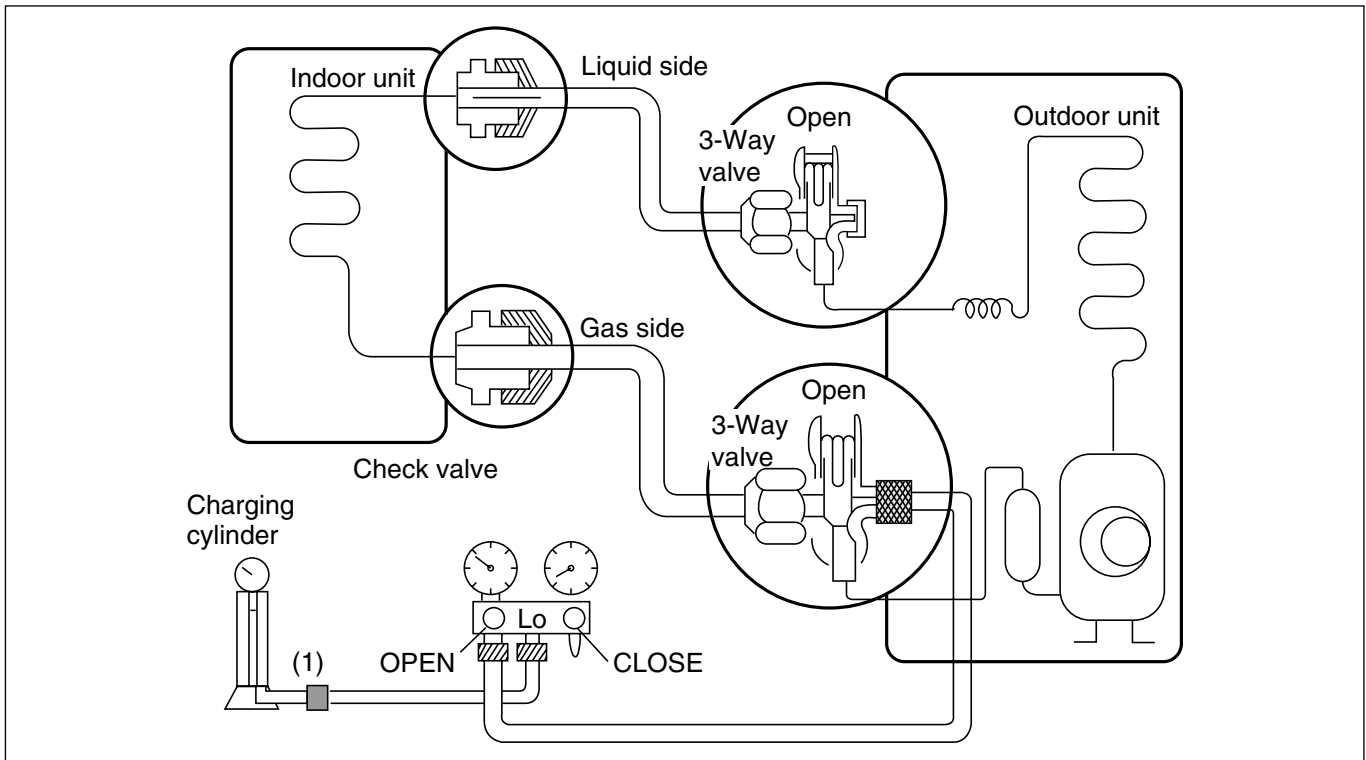

### • Procedure

#### (1) Connect the charge hose to the charging cylinder.

- Connect the charge hose which you disconnected from the vacuum pump to the valve at the bottom of the cylinder.
- If you are using a gas cylinder, also use a scale and reverse the cylinder so that the system can be charged with liquid.

#### (2) Purge the air from the charge hose.

- Open the valve at the bottom of the cylinder and press the check valve on the charge set to purge the air. (Be careful of the liquid refrigerant). The procedure is the same if using a gas cylinder.

#### (3) Open the valve (Lo side on the charge set and charge the system with liquid refrigerant.

- If the system can not be charged with the specified amount of refrigerant, it can be charged with a little at a time (approximately 150g each time) while operating the air conditioner in the cooling cycle; however, one time is not sufficient, wait approximately 1 minute and then repeat the procedure (pumping down-pin).

This is different from previous procedures. Because you are charging with liquid refrigerant from the gas side, absolutely do not attempt to charge with larger amounts of liquid refrigerant while operating the air conditioner.

#### (4) Immediately disconnect the charge hose from the 3-way valve's service port.

- Stopping partway will allow the gas to be discharged.
- If the system has been charged with liquid refrigerant while operating the air conditioner turn off the air conditioner before disconnecting the hose.

#### (5) Mount the valve stem nuts and the service port nut.

- Use torque wrench to tighten the service port nut to a torque of 1.8 kg.m.
- Be sure to check for gas leakage.

## Cycle Parts

### Trouble analysis

1. Check temperature difference between intake and discharge air and operating current.

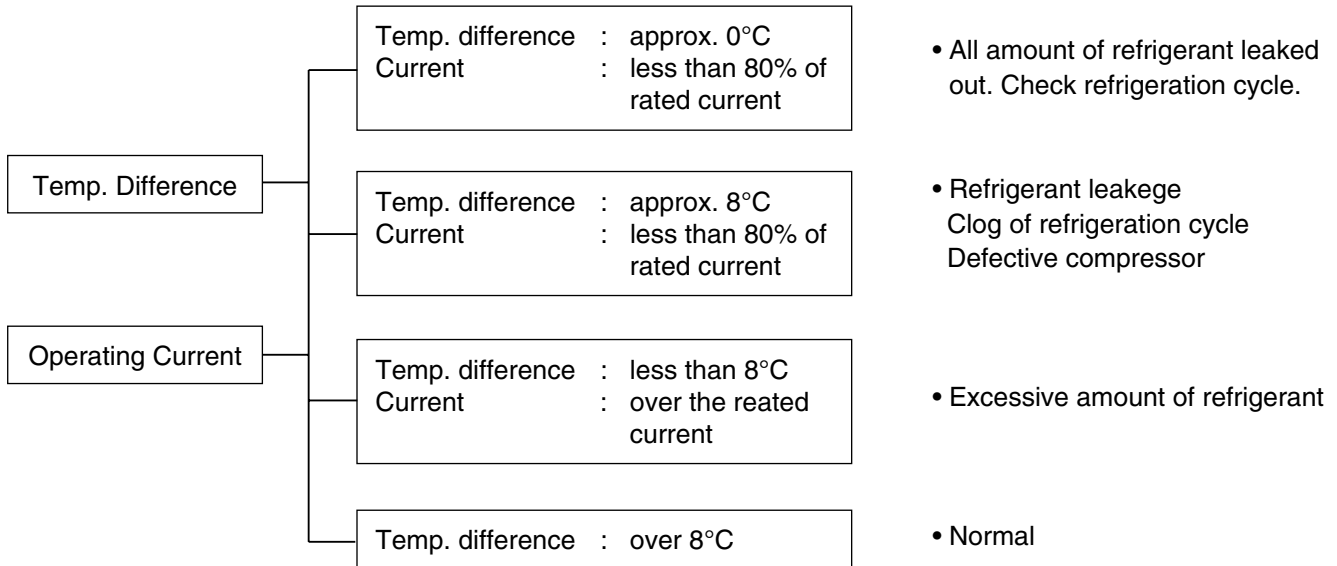

**NOTICE**

Temperature difference between intake and discharge air depends on room air humidity. When the room air humidity is relatively higher, temperature difference is smaller. When the room air humidity is relatively lower temperature difference is larger.

2. Check temperature and pressure of refrigeration cycle.

Suction pressure (Compared with the normal value)	Temperature (Compared with the normal valve)	Cause of Trouble	Description
Higher	High	Defective compressor Defective 4-way reverse valve	Current is low.
	Normal	Excessive amount of refrigerant	High pressure does not quickly rise at the beginning of operation.
Lower	Higher	Insufficient amount of refrigerant (Leakage)	Current is low.
		Clogging	Current is low.

**NOTICE**

1. The suction pressure is usually 4.5~6.0 kg/cm<sup>2</sup>G(Cooling) at normal condition.
2. The temperature can be measured by attaching the thermometer to the low pressure tubing and wrap it with putty.

## Electronic Parts

**Product does not operate at all.**

(\* Refer to Electronic Control Device drawing and Schematic diagram.)

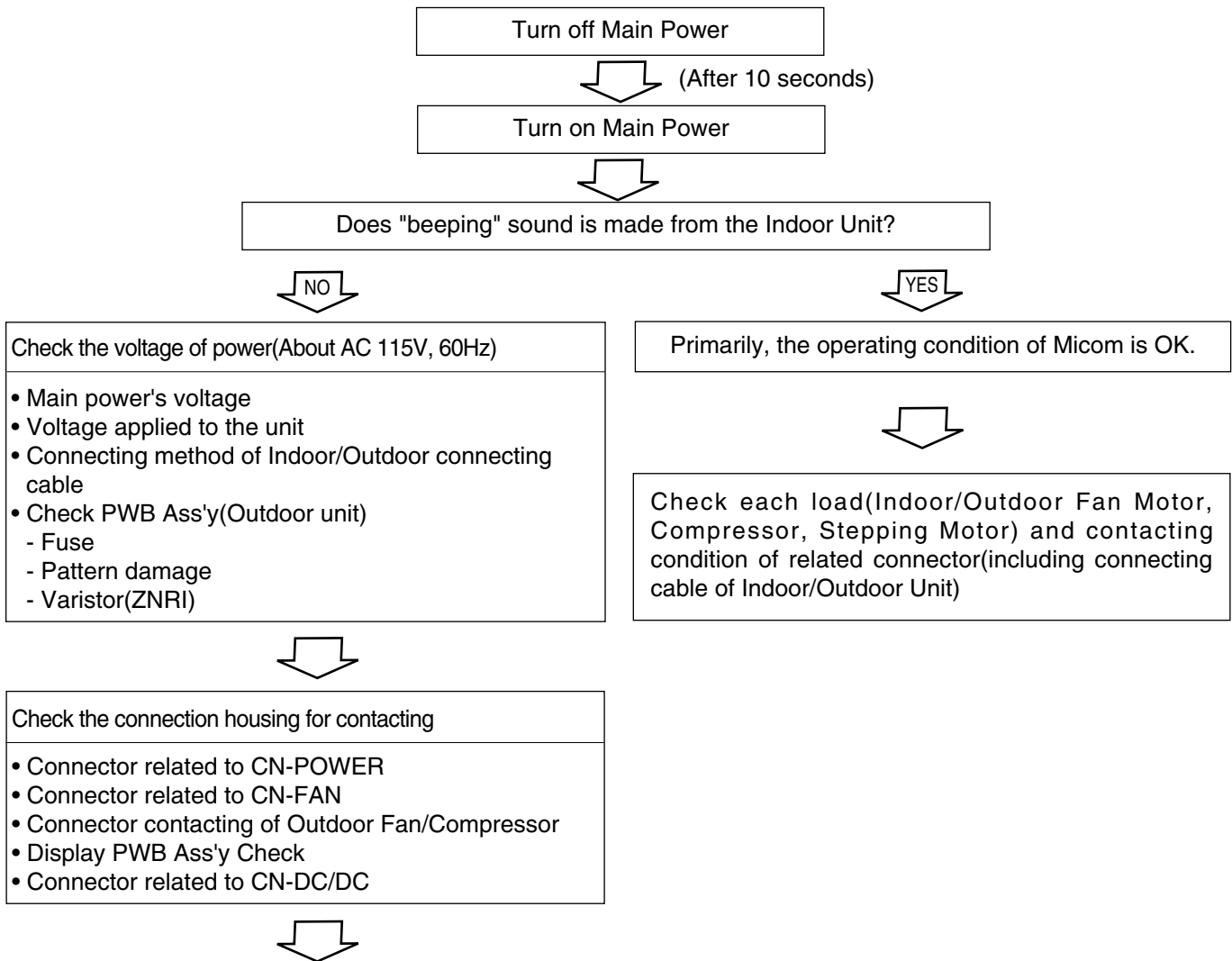

PCB Board Operation Check		
Items	Content	Remedy
<ul style="list-style-type: none"> <li>Power Transformer (Outdoor unit)               <ul style="list-style-type: none"> <li>- Input Voltage</li> <li>- Output Voltage</li> </ul> </li> </ul>	<ul style="list-style-type: none"> <li>- About AC115V±10% - Check the power voltage</li> <li>- About AC17±3V</li> </ul>	<ul style="list-style-type: none"> <li>• Replace Trans</li> </ul>
<ul style="list-style-type: none"> <li>IC2 (Outdoor), IC1Ø (Indoor) Output</li> </ul>	<ul style="list-style-type: none"> <li>• DC +12V</li> </ul>	<ul style="list-style-type: none"> <li>• Replace IC2, IC1Ø</li> </ul>
<ul style="list-style-type: none"> <li>IC3 (Outdoor), ICØ4D (Indoor) Output</li> </ul>	<ul style="list-style-type: none"> <li>• DC +5V</li> </ul>	<ul style="list-style-type: none"> <li>• Replace IC3, ICØ4D</li> </ul>
<ul style="list-style-type: none"> <li>IC4 (Outdoor), IC01A (Indoor), OSCØ1B (8MHz/4MHz)</li> </ul>	<ul style="list-style-type: none"> <li>• Voltage of Outdoor unit Micom No. 8, Voltage of Indoor unit Micom No. 36 and soldering condition</li> </ul>	<ul style="list-style-type: none"> <li>• Replace faulty parts</li> </ul>

## The product does not operate with the remote controller.

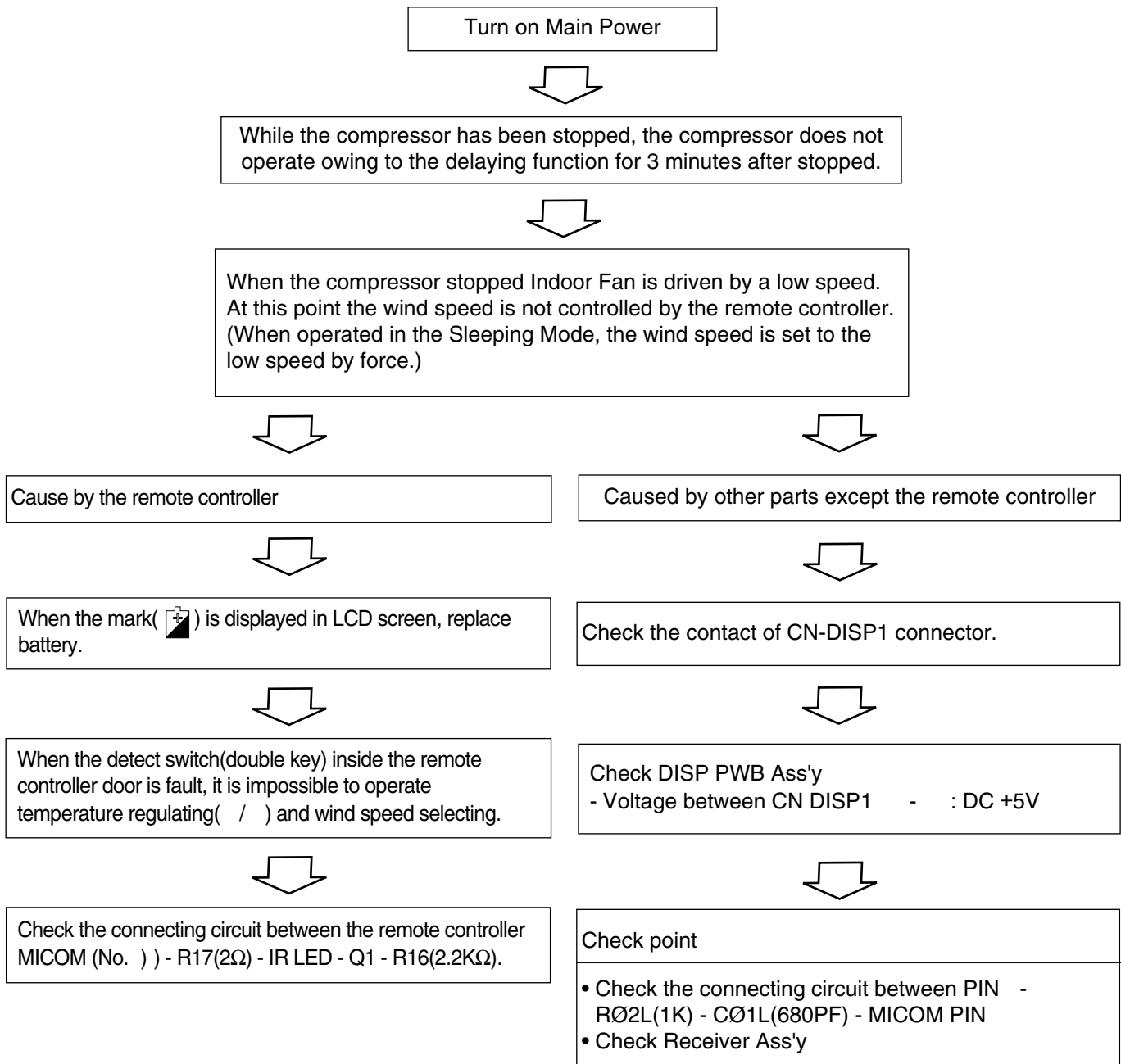

## Compressor/Outdoor Fan are unable to drive.

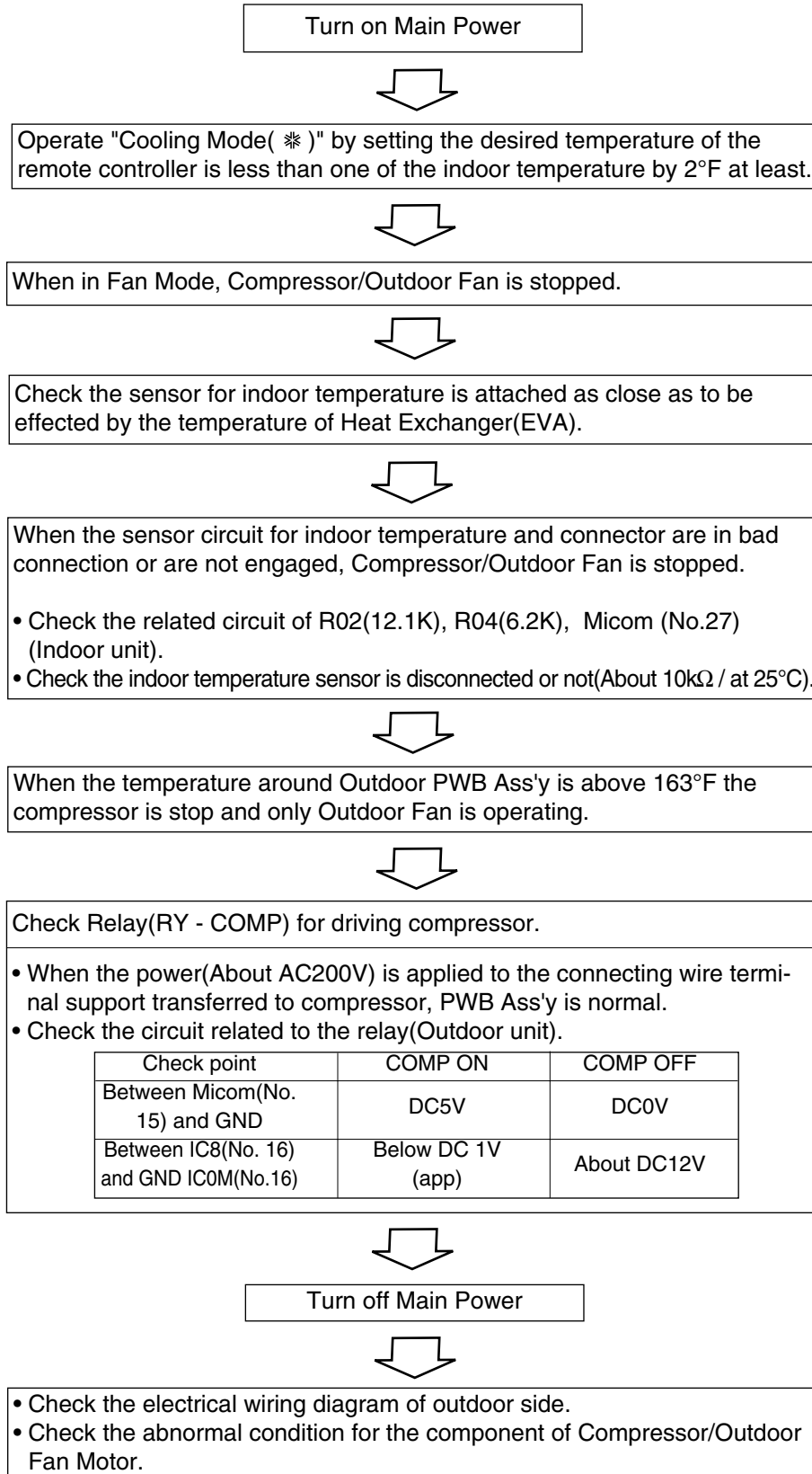

## When Indoor Fan does not operate.

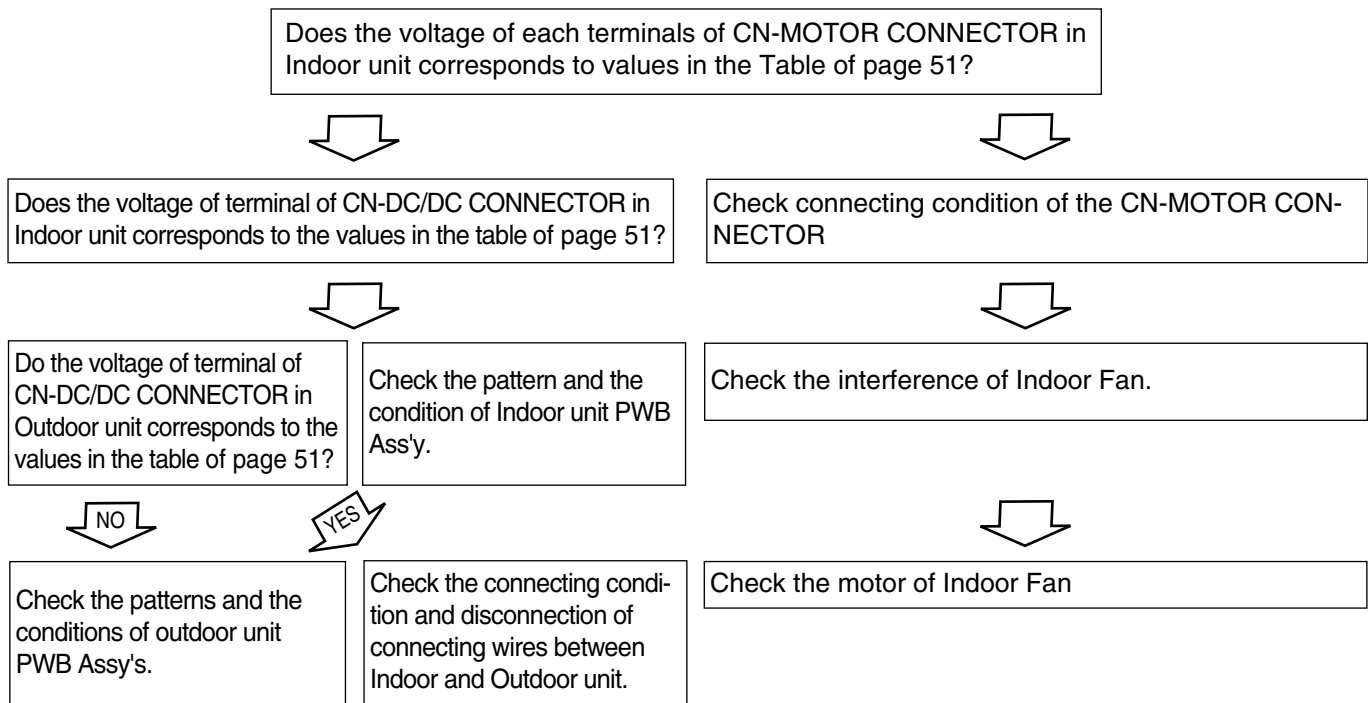

Indoor Fan may be stopped in the Soft Dry Mode(change to the Cooling Operation Mode).

Indoor Fan is to be stopped when Indoor pipe(coil) temperature is lower than 79°F.

(At that times, Defrost indicator is turned on)

## When Left/Right Louvers do not operate.

- Confirm that the Left/Right Vertical Louver is normally geared with the shaft of Stepping Motor.
- If the regular torque is detected when rotating the Left/Right Vertical Louver with hands    Normal



- Check the connecting condition of CN-U/D, CN-L/R Connector
- Check the soldering condition(on PWB) of CN-U/D, CN-L/R Connector



### Check the operating circuit of the Vertical Louver

- Confirm that there is DC +12V between pin    of CN-U/D, CN-L/R and GND.
- Confirm that there is a soldering short at following terminals.
  - Between ⑩, ⑪, ⑫ and ⑬ of ICØ1M
  - Between ⑬, ⑭, ⑮ and ⑰ of ICØ2M
  - Between ⑤④~⑥① and ⑥② of MICOM
  - Between ①, ②, ③, ④ and ⑤ of CN-U/D, CN-L/R



### If there are no problems after above checks

- Confirm the assembly conditions that are catching and interfering parts in the rotation radial of the Vertical Louver

## When Inlet Grille does not operate.

- Confirm that the Inlet Grille is normally geared with the shaft of Stepping Motor.
- If the regular torque is detected when moving the Inlet Grille with hands Normal



- Check the connecting condition of CN-SUB Connector
- Check the soldering condition(on PWB) of CN-SUB Connector



Check the operating circuit of the Vertical Louver

- Confirm that there is DC +12V between pin of CN-SUB and GND.
- Confirm that there is a soldering short at following terminals.
  - Between ④⑤, ④⑩, ④⑧ and ⑤③ of MICOM
  - Between ①, ②, ③ and ④ of CN-SUB



If there are no problems after above checks

- Confirm the assembly conditions that are catching and interfering parts in the rotation radial of the Vertical Louver

## When a communication error occurs.

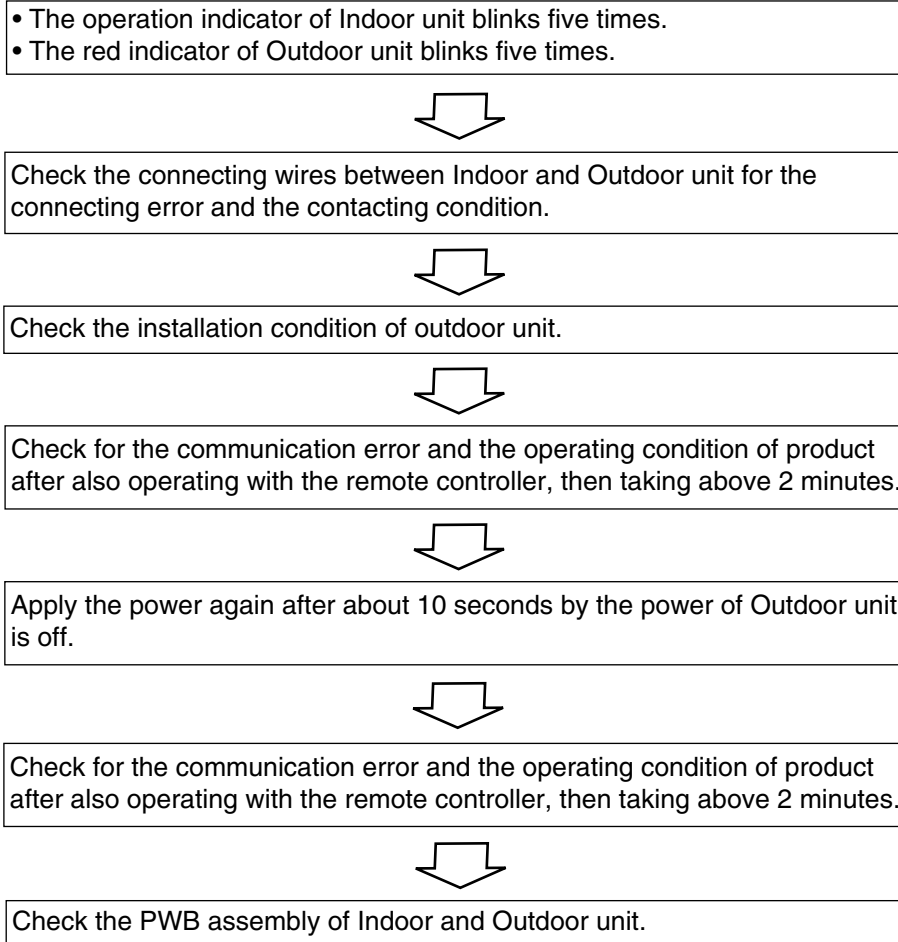

**Caution:** If the connecting wires of Indoor and Outdoor unit are not connected within 2 minutes after the power of Outdoor unit is applied, a communication error will occur. Therefore, the power should be applied after connecting them.

## The phenomena in case of connecting error

### INDOOR UNIT

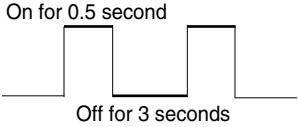
Connector Type	Condition	Phenomena
CN-DC/DC  Blue Black Brown Red	Open and connecting error	<ul style="list-style-type: none"> <li>The same as the phenomenon of Outdoor Unit.</li> </ul>
CN-MOTOR	Open	<ul style="list-style-type: none"> <li>The indoor fan does not operate.</li> <li>The operation indicator of Indoor unit blinks 8 times.</li> </ul>
CN-U/D	Open	<ul style="list-style-type: none"> <li>The up/down vane does not operate.</li> </ul>
	Short between terminals	<ul style="list-style-type: none"> <li>The up/down vane does not smoothly operate.</li> </ul>
CN-DISP1	Open	<ul style="list-style-type: none"> <li>It does not operate with a remote controller.</li> </ul>
CN-TH	Open	<ul style="list-style-type: none"> <li>The operation indicator blinks once.</li> </ul>  <ul style="list-style-type: none"> <li>The compressor and the outdoor fan stop.</li> <li>The indoor fan speed is low.</li> </ul>
	Short between terminals (   and   ) of ROOM-TH.	<ul style="list-style-type: none"> <li>The operation indicator blinks once (on for 0.5 second, off for 3 seconds).</li> <li>The compressor operates continuously regardless of the setting temperature and the variation of room temperature.</li> </ul>
	Short between terminals (   and   ) of PIPE-TH.	<ul style="list-style-type: none"> <li>The operation indicator blinks once (on for 0.5 second, off for 3 seconds)</li> <li>Continuous operation</li> </ul>
CN-L/R	Open	<ul style="list-style-type: none"> <li>The Left/Right vane does not operate.</li> </ul>
	Short between terminals	<ul style="list-style-type: none"> <li>The Left/Right vane does not smoothly operate.</li> </ul>

## Outdoor Unit

Connector Type	Condition	Phenomena
CN-POWER	OPEN	<ul style="list-style-type: none"> <li>All functions stop.</li> <li>The operation with the remote controller, forced and test one do not operate.</li> </ul>
	Connecting reversely	<ul style="list-style-type: none"> <li>PWB pattern is damaged when applying the power.</li> </ul>
RY-COMP terminal	OPEN	<ul style="list-style-type: none"> <li>All functions stop or the compressor does not operate.</li> <li>The operation with the remote controller, forced and test one do not operate.</li> </ul>
	Connecting reversely	<ul style="list-style-type: none"> <li>All functions stop.</li> <li>The operation with the remote controller, forced and test one do not operate.</li> </ul>
CN-TRANS	OPEN	<ul style="list-style-type: none"> <li>All functions stop.</li> <li>The operation with the remote controller, forced and test one do not operate.</li> </ul>
CN-FAN	OPEN	<ul style="list-style-type: none"> <li>The Indoor Fan does not operate.</li> </ul>
The connecting wire of CN-DC/DC, and Indoor and Outdoor Unit  <div style="border: 1px solid black; width: 50px; height: 20px; margin: 5px 0;"></div> Blue Black Brown Red	OPEN	<ul style="list-style-type: none"> <li>All functions stop.</li> <li>The operation with the remote controller, forced and test one do not operate.</li> </ul>
	Connecting error ( )	<ul style="list-style-type: none"> <li>The only signal of remote controller operation/stop is inputted, but the product does not operate.</li> <li>The RED indicator of outdoor unit blinks 5 times after 2 minutes with applying the power.</li> </ul>
	Connecting error ( )	<ul style="list-style-type: none"> <li>The beep sound, such as "beep, beep, beep, beep, beep", occurs periodically in Indoor unit.</li> <li>The signal input of a remote controller and operation of product is impossible.</li> <li>The RED indicator blinks 5 times after 2 minutes with applying the power.</li> </ul>
	Connecting error ( )	<ul style="list-style-type: none"> <li>The signal of remote controller is inputted, but the product does not operate.</li> <li>The RED indicator of outdoor unit and the operation indicator of indoor one blinks 5 times after 2 minutes with applying the power.</li> </ul>
	Connecting error ( )	<ul style="list-style-type: none"> <li>No power for Indoor unit.</li> <li>The signal input of the remote controller and operation of product is impossible.</li> <li>The thermal protector of the Power Trans operates when let it alone for long time.</li> </ul>
	Connecting error ( )	<ul style="list-style-type: none"> <li>The signal of the remote controller is inputted.</li> <li>The fuse and Q61 in the Outdoor unit are damaged when the indoor fan is operated.</li> </ul>
	Connecting error ( )	<ul style="list-style-type: none"> <li>No power for Indoor unit.</li> <li>The signal input of the remote controller and operation of product is impossible.</li> <li>The RED indicator of the Outdoor unit blinks 5 times after 2 minutes with applying the power.</li> </ul>

# Exploded View & Replacement Parts List

## Indoor Unit

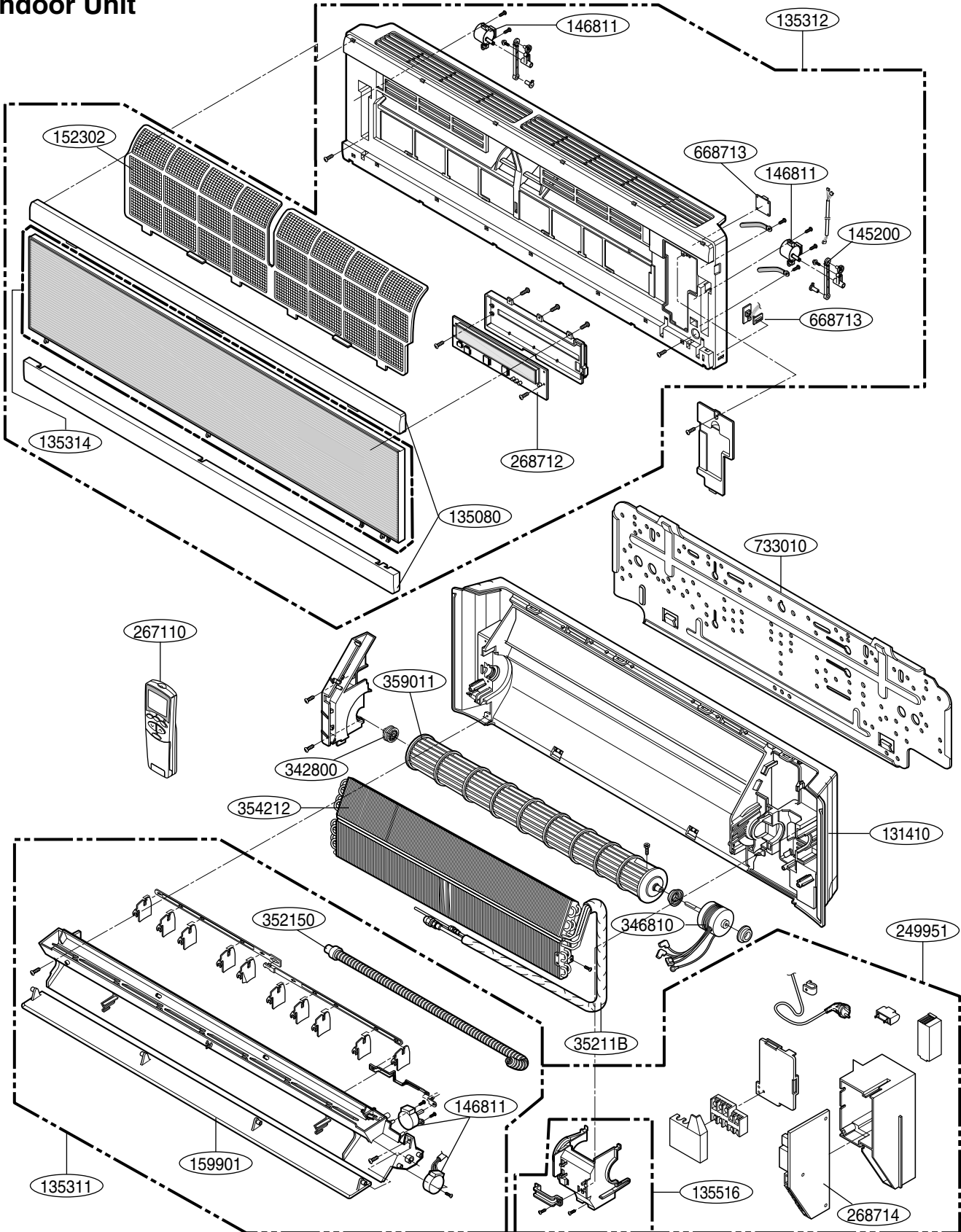

## Parts List(Indoor)

LOCATION No.	DESCRIPTION		PART No.	REMARKS
			LA140CE/LA141CE	
131410	CHASSIS ASSEMBLY		3141A20007B	R
135080	DECORATION (TOP)		3508A20034F	R
135080	DECORATION (BOTTOM)		3508A20034E	R
135311	GRILLE ASSEMBLY, DISCHARGE		3531A10137E	R
135314	GRILLE ASSEMBLY, INLET	MIRROR	3531A20118E	R
		BLUE	3531A21010E	R
		WHITE	3531A20138W	R
		METAL	3531A20138Y	R
		CHERRY	3531A20138Z	R
135312	GRILLE ASSEMBLY, FRONT	MIRROR	3531A10147H	R
		BLUE	3531A20238E	R
		WHITE	3531A10158P	R
		METAL	3531A10158R	R
		CHERRY	3531A10158S	R
145200	LINK		4520A20008A	R
146811	MOTOR ASSEMBLY, STEP		4681A20055A	R
146811	MOTOR ASSEMBLY, STEP		4681A20055B	R
152302	FILTER (MECH), A/C		5230A20022A	R
159901	VANE HORIZONTAL		5990A20015B	R
249951	CONTROL BOX ASSEMBLY		4995A10138A	R
268712	DISPLAY LED ASSEMBLY		6327A90023D	R
263230	THERMISTOR ASSEMBLY		6323A20004H	R
267110	REMOTE CONTROLLER ASSEMBLY		6711A20083Q	R
268714	PWB(PCB) ASSEMBLY, MAIN		6871A20535A	R
342800	BEARING		4280A20004A	R
346810	MOTOR ASSEMBLY, INDOOR		4681A	R
35211B	TUBE ASSEMBLY, TUBING		5211A21419B	R
352150	HOSE ASSEMBLY, DRAIN		5251AR1222R	R
354212	EVAPORATOR ASSEMBLY, FIRST		5421A20086D	R
354212	EVAPORATOR ASSEMBLY, FINAL		5421A20105P	R
359011	FAN ASSEMBLY, CROSS FLOW		5901A20016J	R
668713	PWB ASSEMBLY, SUB		6871A20258C	R
668713	PWB ASSEMBLY, SUB		6871A20259A	R
73310	PLATE		1H00843A	R
W0CZZ	CAPACITOR,DRAWING		-	R
135516	COVER ASSEMBLY,MOTOR		3551A20050C	R

## Outdoor unit

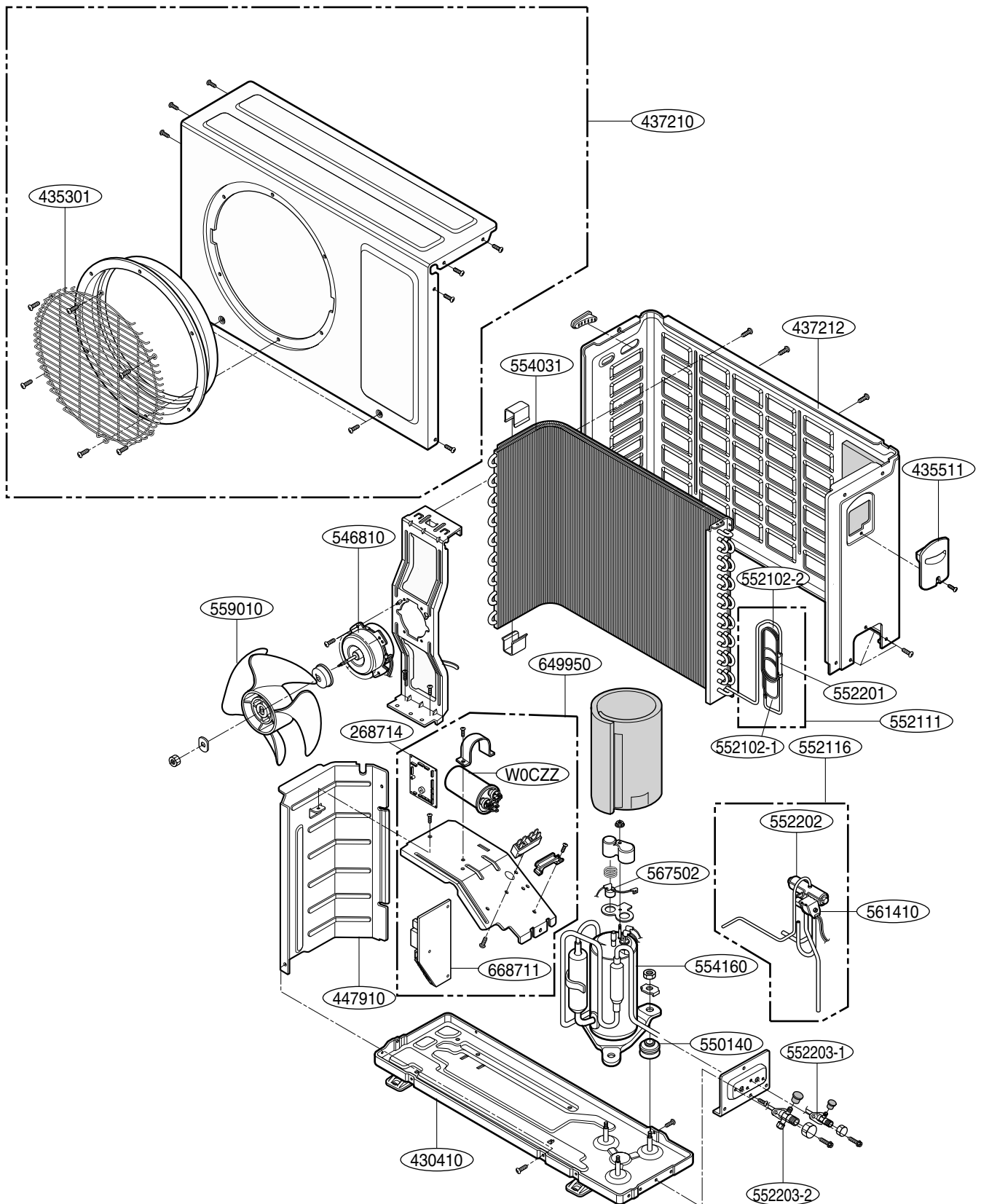

**Parts List(Outdoor)**

LOCATION No.	DESCRIPTION	PART No.	REMARKS
		LA140CE/LA141CE	
430410	BASE ASSEMBLY, OUTDOOR	3041A20008J	R
435511	COVER ASSEMBLY, CONTROL	3551AR7184R	R
437210	PANEL ASSEMBLY, FRONT	3721A20027P	R
437212	PANEL ASSEMBLY REAR	3721A20026K	R
447910	BARRIER ASSEMBLY, OUTDOOR	4791A30002F	R
546810	MOTOR ASSEMBLY, OUTDOOR	4681A20004R	R
550140	ISOLATOR, COMP.	4H00982E	R
552102-1	TUBE, CAPILLARY BEND	-	R
552102-2	TUBE, CAPILLARY BEND	5210A30041U	R
552111	TUBE ASSEMBLY, CAPILLARY	5211A21143H	R
552116	TUBE ASSEMBLY, REVERSING	-	R
552201	VALVE, CHECK	-	R
552202	VALVE, REVERSING	-	R
552203-1	VALVE, SERVICE	5220A20005B	R
552203-2	VALVE, SERVICE	5220A20003B	R
554031	CONDENSER ASSEMBLY, BENT	5403A20019B	R
554160	COMPRESSOR	2520UKJC2AA	R
559010	FAN ASSEMBLY, PROPELLER	5901A10004A	R
W0CZZ	CAPACITOR, DRAWING	0CZZA20001L	R
435301	GRILLE, DISCHARGE	3530A20006G	R
561410	COIL ASSEMBLY, REVERSING VALVE	-	R
567502	O.L.P	6750U-L046A	R
649950	CONTROL BOX ASSEMBLY, OUTDOOR	4995A10038G	R
668711	PCB ASSEMBLY, MAIN	6871A10036Q	R
268714	PCB ASSEMBLY, MAIN	6871A20522A	R

