

HEAT CONTROLLER, INC.



**Wall Mounted
Mini-Split System
Air Conditioning/Heat Pump**
Service Manual

Model: MSS-009B/A
MSS-012B/A, MSH-012B/A
MSS-018B/A, MSH-018B/A
MSS-024B/A, MSH-024B/A

CAUTION

Before servicing the unit, read the
“safety precautions” in this manual.

Only for authorized service personnel.

Contents

Functions.....	3
Product Specifications	5
Dimensions.....	7
Refrigeration Cycle Diagram.....	9
Wiring Diagram	11
Operation Details	14
Test Mode	22
Display Function	23
Self-diagnosis Function	23
Installation	24
Operation	41
Disassembly of the Parts(Indoor Unit).....	43
Cycle Troubleshooting Guide	49
Electronic Control Device	59
Schematic Diagram.....	62
Exploded View.....	64

Functions

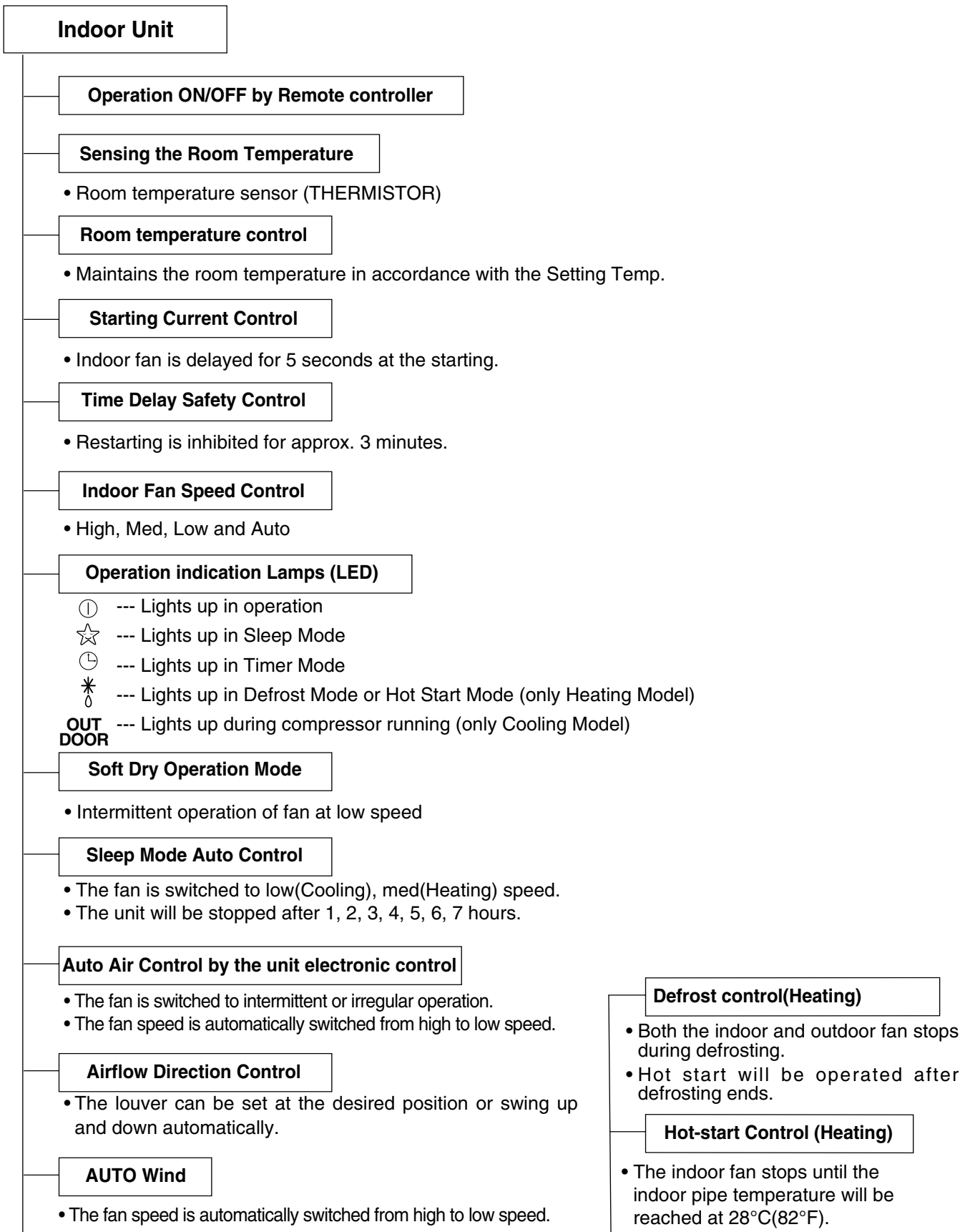

Remote Controller

Operation ON/OFF



Operation Mode Selection

Cooling Operation Mode. (*) Auto Operation Mode. (▲)
 Soft Dry Operation Mode. (◊) Heating Operation Mode. (☼)
(Cooling model only) (Heating model only)

Fan Speed Selection

(Low) (Med) (High) (AUTO WIND)

Room Temperature Display

: (High: 98°F ↔ LOW : 54°F)

Temperature Setting

Cooling — Down to 64°F / Up to 86°F Heating — Down to 60°F / Up to 86°F

Setting the Time or Timer

Timer Selection

: OFF, ON, OFF ↔ ON

Timer Setting

Timer Cancel

: Cancel Sleep Mode, Timer ON or Timer OFF

Sleep Operation

: 1, 2, 3, 4, 5, 6, 7, Off Timer

Airflow Direction Control

Fan Operation Mode

: Fan Operates without cooling or heating.

Reset

○ RESET

Product Specifications(Cooling Only)

Items		Unit	MSS-009B/A	MSS-012B/A	MSS-018B/A	MSS-024B/A
Power Supply		ø, V, Hz	1,115, 60	1,115, 60	1,230/208,60	1,230/208,60
Cooling Capacity		Btu/h	9,000	12,000	18,000/17,800	23,000/22,600
Input		W	940	1,290	1,900/1,870	2,550/2,500
Running Current		A	8.5	11.7	8.5/9.0	11.5/12.0
COMP. Locked Rotor AMP.		A	25	27	49.5	68
E.E.R		Btu/hW	9.6	9.5/9.5	9.5/9.5	9.0/9.0
Air Circulation	Indoor(Dry)	m ³ /min(cfm)	8(280)	10(350)	13(460)	15(530)
	Outdoor(Dry)	m ³ /min(cfm)	25(882)	25(882)	46(1,610)	46(1,610)
Moisture Removal		l/h(pts/hr)	1.5(3.2)	1.7(3.63)	2.5(5.3)	3.1(6.6)
Features	Temperature Control		Thermistor	Thermistor	Thermistor	Thermistor
	AUTO Wind		Yes	Yes	Yes	Yes
	Air Deflection		4-way	4-way	4-way	4-way
	Steps, Fan/Cool		3/3	3/3	3/3	3/3
	Airflow Direction Control(up&down)		Auto	Auto	Auto	Auto
	Airflow Direction Control(left&right)		Manual	Manual	Manual	Manual
	Remocon Type		Wireless LCD	Wireless LCD	Wireless LCD	Wireless LCD
	Setting Temperature Range, Cooling Mode		64~86°F	64~86°F	64~86°F	64~86°F
	Temperature Increment		2°F	2°F	2°F	2°F
	Auto Operation(electronic control)		Yes	Yes	Yes	Yes
	Self Diagnosis		Yes	Yes	Yes	Yes
	Timer		24hr, On/Off	24hr, On/Off	24hr, On/Off	24hr, On/Off
	Sleep Operation		Yes	Yes	Yes	Yes
	Soft Dry Operation		Yes	Yes	Yes	Yes
Restart Delay	minutes	3	3	3	3	
Refrigerant(R-22) Charge		g(oz)	740(26.1)	1,200(42.3)	1,530(54.0)	1,710(60.3)
Power cord		AWG #: P*mm ²	14:3*2.1	14:3*2.1	14:3*2.1	14:3*2.1
Fuse or breaker Capacity		A	15A	15A	15A	20A
Connecting Cable		AWG #: P*mm ²	18:4*0.82	18:4*0.82	18:4*0.82	18:4*0.82
Connecting Tube	Liquid Side	mm(in)	6.35(1/4)	6.35(1/4)	9.52(3/8)	9.52(3/8)
	Gas Side	mm(in)	12.7(1/2)	12.7(1/2)	15.88(5/8)	15.88(5/8)
(ø. Socket Flare)	Length, std	m(ft)	7.62(25)	7.62(25)	7.62(25)	7.62(25)
Additional Drain Hose(Inner Dia.)		mm(in)	16(5/8)	16(5/8)	16(5/8)	16(5/8)
Dimensions (WxHxD)	Indoor	mm	900*290*183	900*290*183	1080*290*183	1080*290*183
		in	35.4*11.4*7.2	35.4*11.4*7.2	42.5*11.4*7.2	42.5*11.4*7.2
	Outdoor	mm	801*555*262	801*555*262	870*655*320	870*655*320
		in	31.5*21.8*10.3	31.5*21.8*10.3	34.3*25.8*12.6	34.3*25.8*12.6
Net Weight	Indoor	kg(lbs)	9(20)	10(22)	12(26.5)	12(26.5)
	Outdoor	kg(lbs)	35(77)	34(75)	54(119)	64(141)

* Design and Specifications subject to change without prior notice for product improvement.

Product Specifications(Cooling & Heating)

Items		Unit	MSH-012B/A	MSH-018B/A	MSH-024B/A
Power Supply		ø, V, Hz	1,115, 60	1,230/208,60	1,230/208,60
Cooling Capacity		Btu/h	12,000	18,000/17,800	23,000/22,600
Heating Capacity		Btu/h	12,000	19,000/18,700	23,000/22,600
Input	Cooling	W	1,290	1,900/1,870	2,550/2,500
	Heating	W	1,290	1,900/1,870	2,550/2,500
Running Current	Cooling	A	11.7	8.5/9.0	11.5/12.0
	Heating	A	11.7	8.5/9.0	11.5/12.0
COMP. Locked Rotor AMP.	Cooling	A	27	49.5	68
	Heating	A	27	49.5	68
E.E.R		Btu/hW	9.5/9.5	9.5/9.5	9.0/9.0
C.O.P			2.78/2.78	2.9/2.9	2.6/2.6
Air Circulation	Indoor(Dry)	m³/min(cfm)	10(350)	13(460)	15(530)
	Outdoor(Dry)	m³/min(cfm)	25(882)	46(1,610)	46(1,610)
Moisture Removal		l/h(pts/hr)	1.7(3.63)	2.5(5.3)	3.1(6.6)
Features	Temperature Control		Thermistor	Thermistor	Thermistor
	AUTO Wind		Yes	Yes	Yes
	Air Deflection		4-way	4-way	4-way
	Steps, Fan/Cool/Heat		3/3/3	3/3/3	3/3/3
	Airflow Direction Control(up&down)		Auto	Auto	Auto
	Airflow Direction Control(left&right)		Manual	Manual	Manual
	Remocon Type		Wireless LCD	Wireless LCD	Wireless LCD
	Setting Temperature Range, Cooling Mode		64~86°F	64~86°F	64~86°F
	Heating Mode		60~86°F	60~86°F	60~86°F
	Temperature Increment		2°F	2°F	2°F
	Auto Operation(electronic control)		Yes	Yes	Yes
	Self Diagnosis		Yes	Yes	Yes
	Timer		24hr, On/Off	24hr, On/Off	24hr, On/Off
	Sleep Operation		Yes	Yes	Yes
	Soft Dry Operation		Yes	Yes	Yes
	Restart Delay	minutes	3	3	3
	Defrost Control		Yes	Yes	Yes
	Hot Start		Yes	Yes	Yes
Refrigerant(R-22) Charge		g(oz)	1,230(44.1)	1,500(52.9)	1,600(56.4)
Power cord		AWG #: P*mm²	14:3*2.1	14:3*2.1	14:3*2.1
Fuse or breaker Capacity		A	15A	15A	20A
Connecting Cable		AWG #: P*mm²	18:4*0.82	18:4*0.82	18:4*0.82
Connecting Tube (ø. Socket Flare)	Liquid Side	mm(in)	6.35(1/4)	9.52(3/8)	9.52(3/8)
	Gas Side	mm(in)	12.7(1/2)	15.88(5/8)	15.88(5/8)
Length, std		m(ft)	7.62(25)	7.62(25)	7.62(25)
Additional Drain Hose(Inner Dia.)		mm(in)	16(5/8)	16(5/8)	16(5/8)
Dimensions (WxHxD)	Indoor	mm	900*290*183	1080*290*183	1080*290*183
		in	35.4*11.4*7.2	42.5*11.4*7.2	42.5*11.4*7.2
	Outdoor	mm	801*555*262	870*655*320	870*655*320
		in	31.5*21.8*10.3	34.3*25.8*12.6	34.3*25.8*12.6
Net Weight	Indoor	kg(lbs)	10(22)	12(26.5)	12(26.5)
	Outdoor	kg(lbs)	35(77)	55(121)	65(143)

* Design and Specifications subject to change without prior notice for product improvement.

Dimensions

(1) Indoor Unit

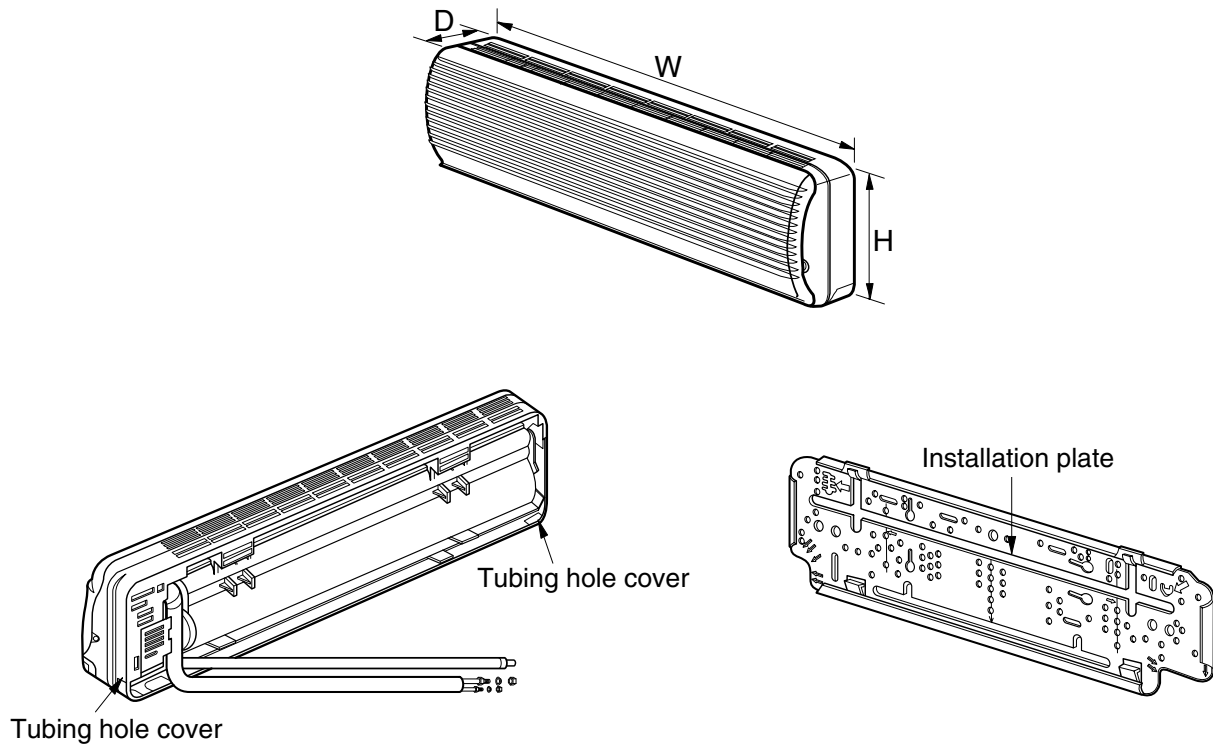

DIM \ MODEL		9k, 12k	18k, 24k
W	mm(inch)	900(35.4")	1,080(42.5")
H	mm(inch)	290(11.4")	290(11.4")
D	mm(inch)	183(7.2")	183(7.2")

(2) Outdoor Unit

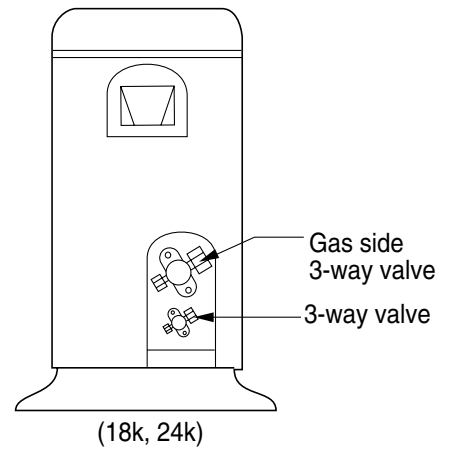
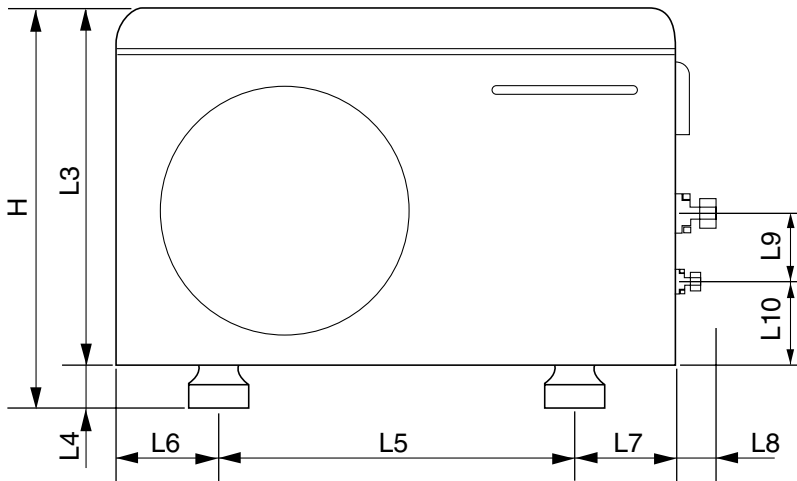
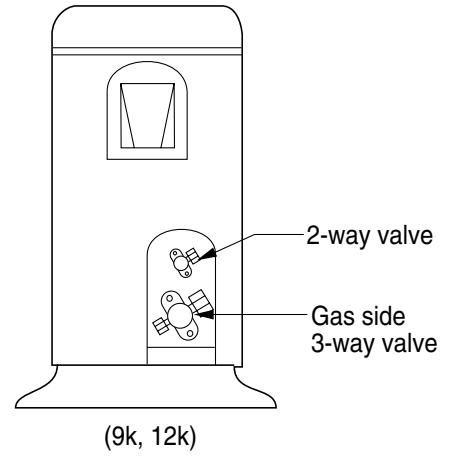
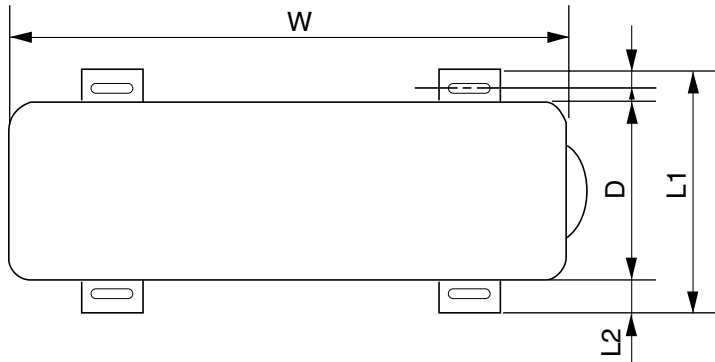

MODEL		9k, 12k	18k, 24k
DIM			
W	mm(inch)	801(31.5)	870(34.3)
H	mm(inch)	555(21.8)	655(25.8)
D	mm(inch)	262(10.3)	320(12.6)
L1	mm(inch)	339(13.3)	370(14.6)
L2	mm(inch)	37(1.5)	25(1.0)
L3	mm(inch)	543.6(21.4)	630(24.8)
L4	mm(inch)	11.4(0.45)	25(1.0)
L5	mm(inch)	591(23.3)	546(21.5)
L6	mm(inch)	105(4.13)	162(6.4)
L7	mm(inch)	105(4.13)	162(6.4)
L8	mm(inch)	72.5(2.85)	54(2.1)
L9	mm(inch)	77(3.03)	74.5(2.9)
L10	mm(inch)	86.4(3.4)	79(3.1)

Refrigeration Cycle Diagram

• Cooling Only Models

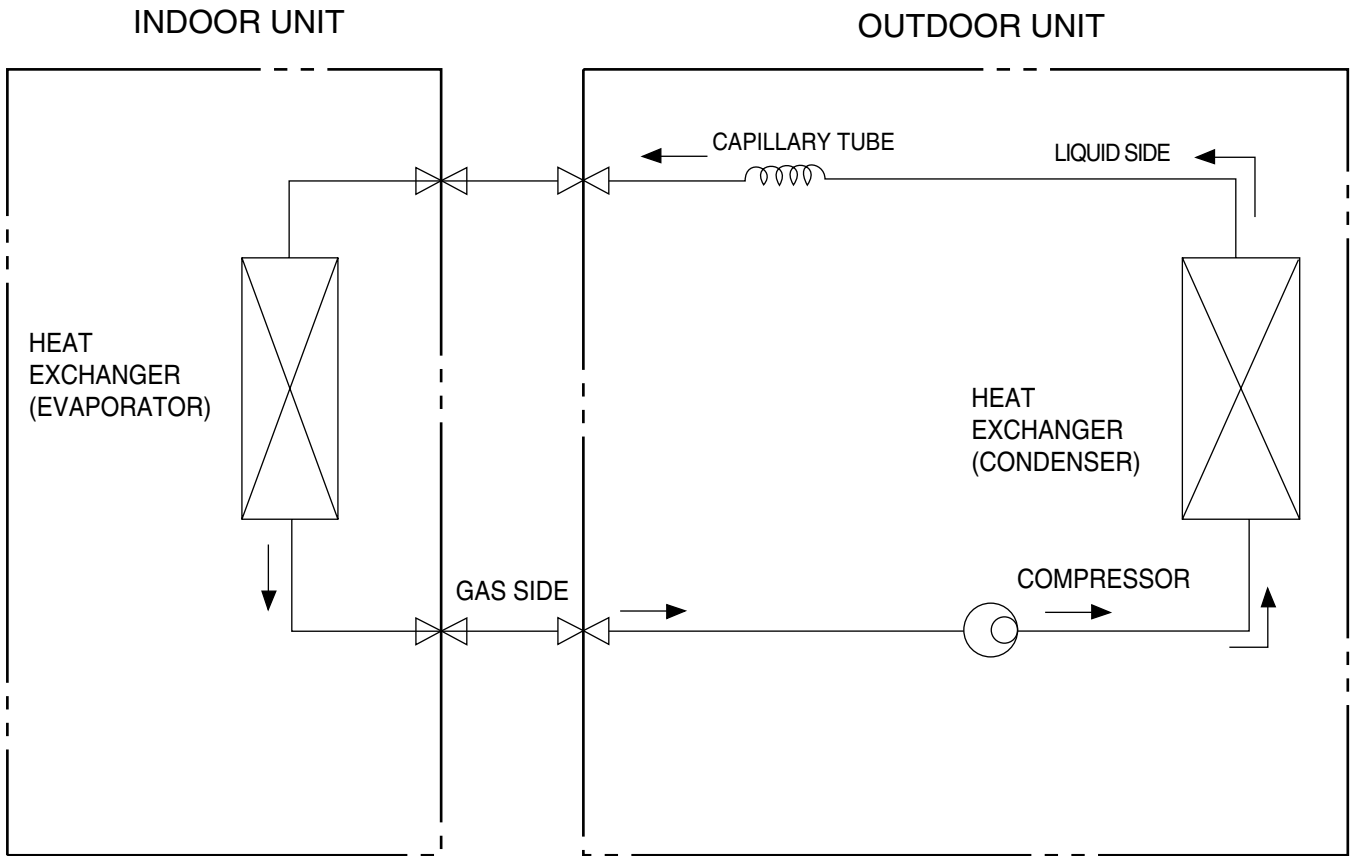

MODEL	Pipe size(Diameter:ø)		Piping length		Elevation	
	Gas	Liquid	Rated	Max	Rated	Max
9k, 12k (Cooling Only)	1/2"	1/4"	7.62m(25ft)	15m(50ft)	5m(16ft)	8m(26ft)
18k, 24k (Cooling Only)	5/8"	3/8"	7.62m(25ft)	15m(50ft)	5m(16ft)	8m(26ft)

For installation over rated, *a proper quantity of refrigerant should be added for each 5 foot.

a proper quantity of refrigerant	
9k, 12k	0.2 Oz
18k, 24k	0.3 Oz

Ex) 18K: When installed at a distance of 30ft, 1.5 Oz of refrigerant should be added.
 $(30-25) \times 0.302 = 1.5$ Oz of refrigerant to add

Unit precharged for 25ft. line sets.

• Cooling & Heating Models

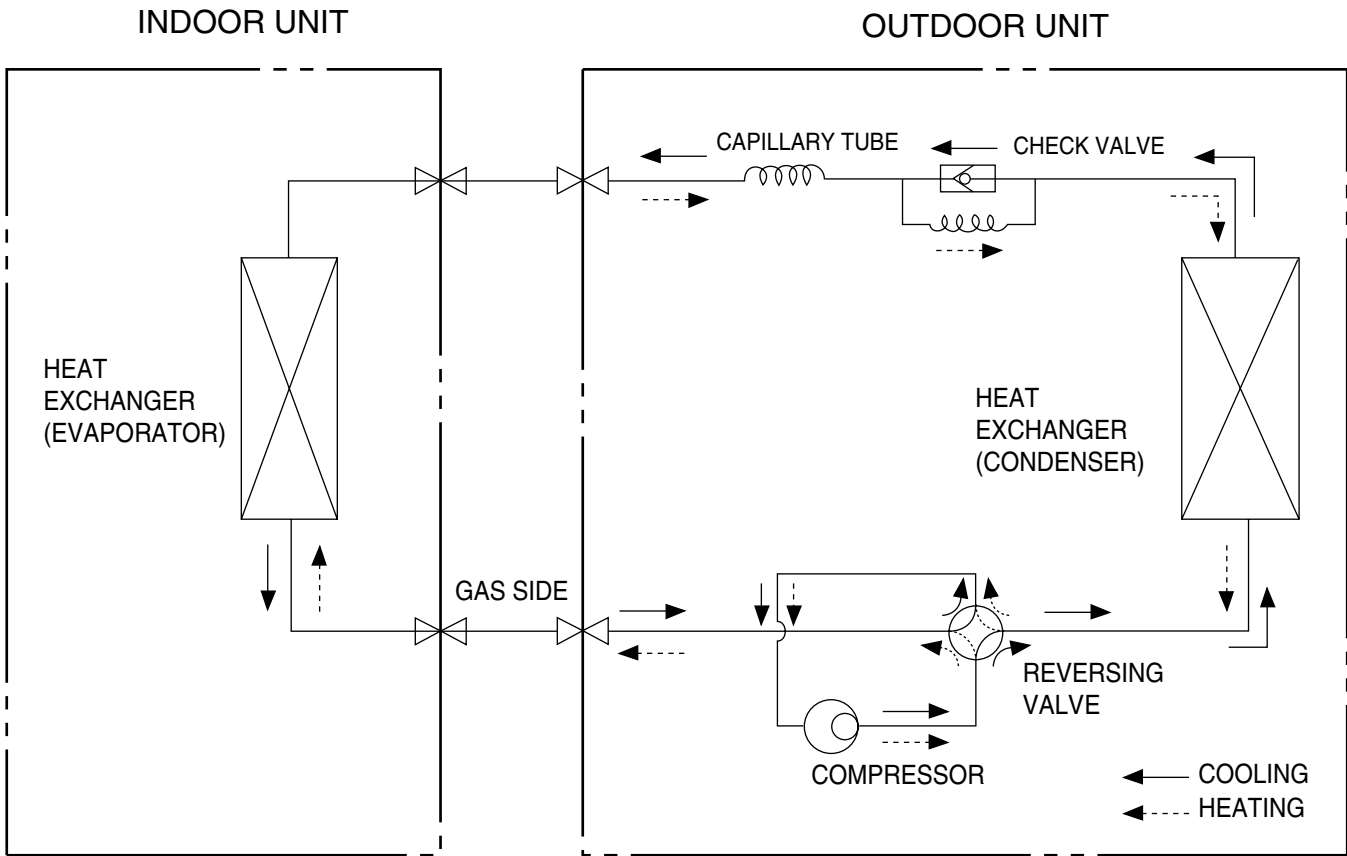

MODEL	Pipe size(Diameter:ø)		Piping length		Elevation	
	Gas	Liquid	Rated	Max	Rated	Max
9k, 12k (Cooling & Heating)	1/2"	1/4"	7.62m(25ft)	15m(50ft)	5m(16ft)	8m(26ft)
18k, 24k (Cooling & Heating)	5/8"	3/8"	7.62m(25ft)	15m(50ft)	5m(16ft)	8m(26ft)

For installation over rated, *a proper quantity of refrigerant should be added for each foot.

a proper quantity of refrigerant	
9k, 12k	0.2 Oz
18k, 24k	0.3 Oz

Ex) 18K: When installed at a distance of 30ft, 1.5 Oz of refrigerant should be added.
 $(30-25) \times 0.302 = 1.5$ Oz of refrigerant to add

Unit precharged for 25ft. line sets.

Wiring Diagram

(1) Indoor Unit

1. MSS-012, MSS-018, MSH-018, MSS-024, MSH-024

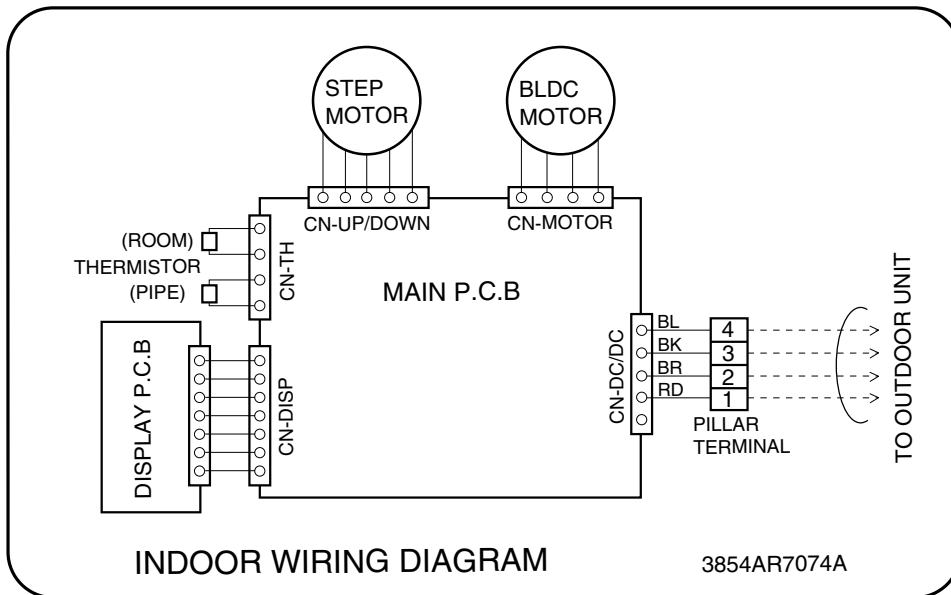

2. MSS-009, MSS-012

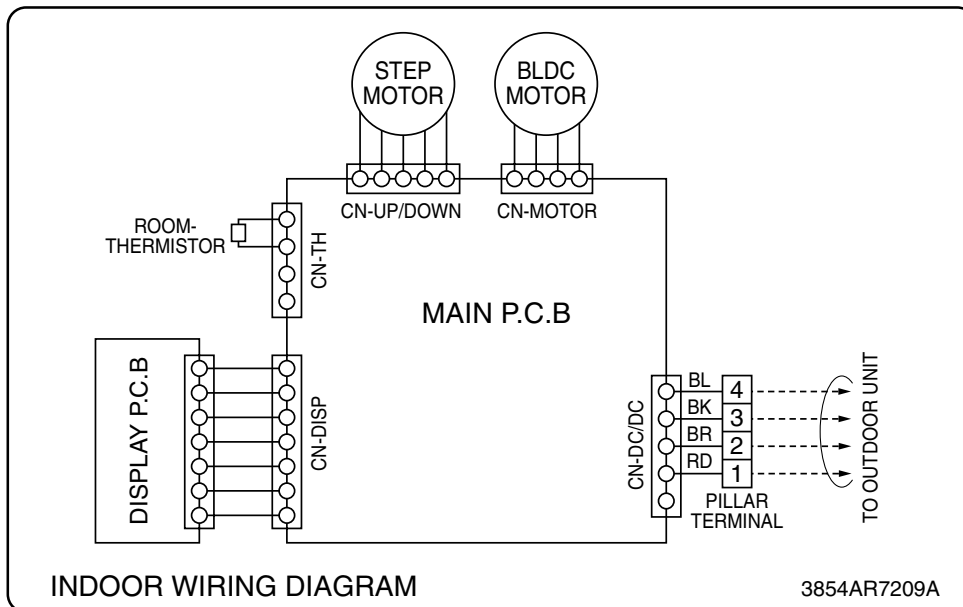

(2) Outdoor Unit

• Cooling Only Models

1. 9k, 12k

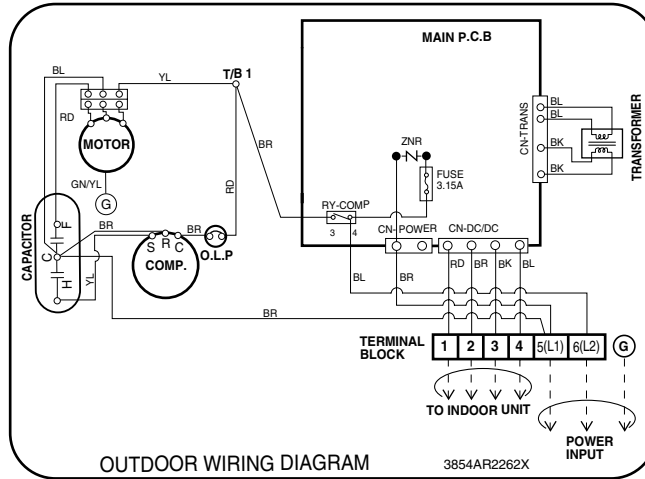

2. 18k

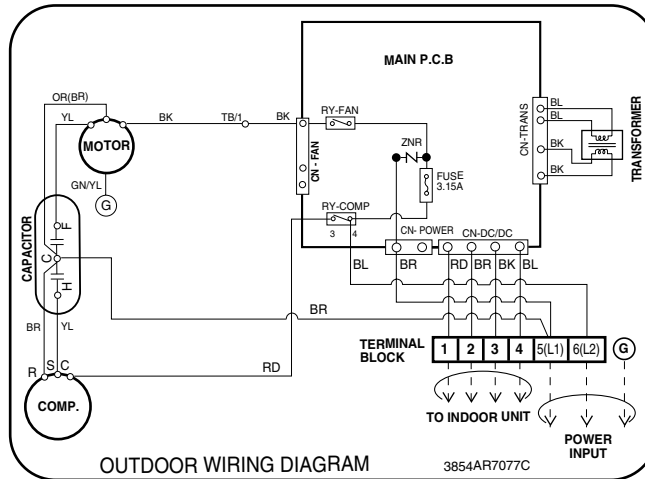

3. 24k

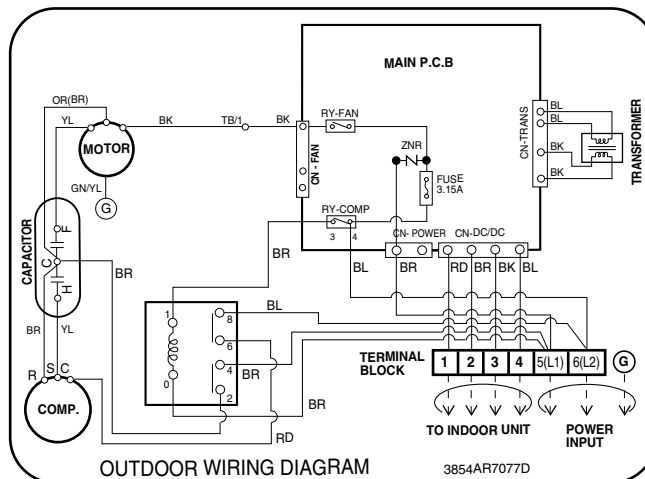

• Cooling & Heating Models

1. 12k

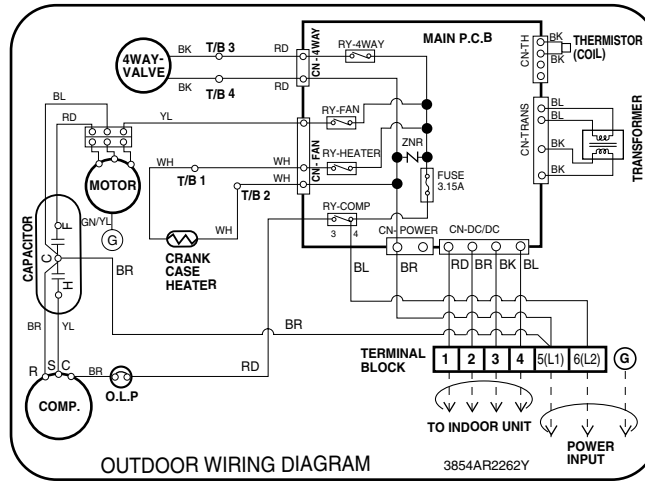

2. 18k

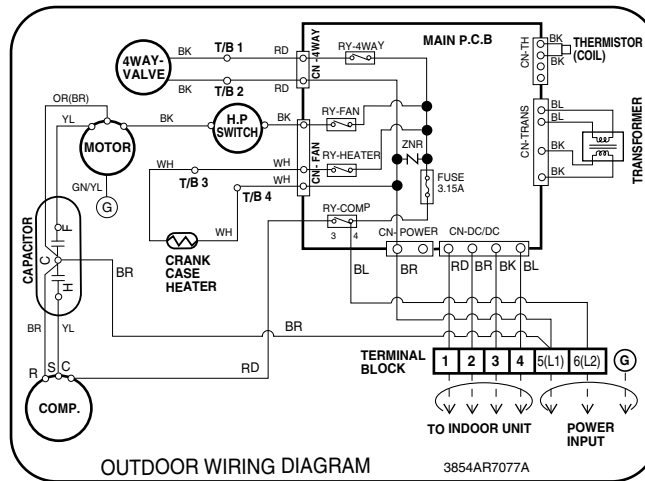

3. 24k

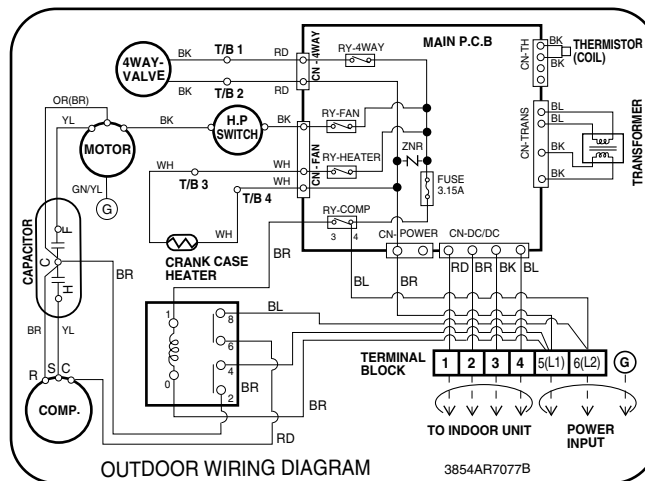

Operation Details

(1) The function of main control

1. Time delay Safety Control

- 3min.; The compressor operation is delayed for 3 minutes to balance the pressure of cycle.
(Protection of compressor)
- 5sec.; The indoor fan is delayed for 5 seconds, when operating initially, to prevent noises occurred by the vertical louver and wind.
- 2min.; The reversing valve is delayed for 2 minutes to prevent the refrigerant-gas for abnormal noise when the heating operation is OFF or switched to the other operation mode while compressor is off. While compressor is running, it takes 3~5 seconds to switch.

2. Airflow Direction Control

- This function is to swing the vertical louver up and down automatically and to set it at a fixed position.
- The procedure is as the following.
 - 1st ; Press the ON/OFF Button to operate the unit.
 - 2nd ; Press the Airflow Direction Control Button to swing the vertical louver up and down automatically.
 - 3rd ; Reprress the Airflow Direction Control Button to set the vertical louver at a fixed position.

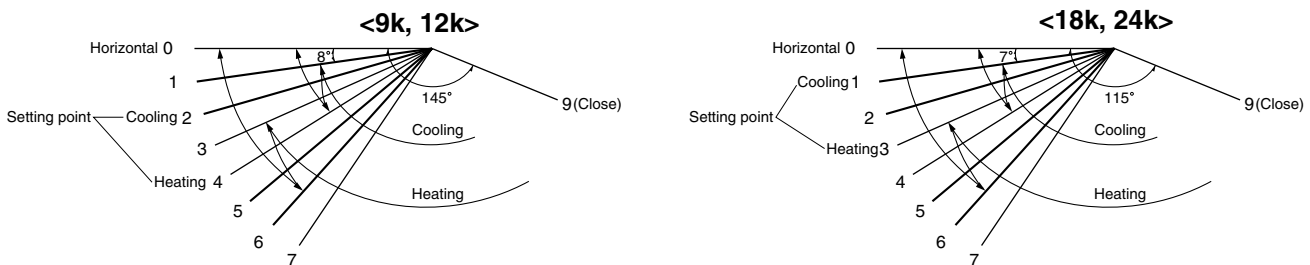

3. Cooling Operation Mode

- When selecting the Cooling(*) Mode Operation, the unit will operate according to the setting by the remote controller and the operation diagram is shown below.

INTAKE AIR TEMP.					
SETTING TEMP. +1°F (Compressor ON)					
SETTING TEMP. -1°F (Compressor OFF)	More than 3 minutes		More than 3 minutes		
INDOOR FAN SPEED	Selecting fan speed	Low	Selecting fan speed	Low	Selecting fan speed
COMPRESSOR	ON	OFF	ON	OFF	ON

■ Protection of the indoor heat exchanger from frosting

- Compressor and outdoor fan stop when indoor pipe temperature is below 32°F and restart at the pipe temperature is above 45°F.

4. Auto Operation (Electronic control mode)

- The operation procedure is shown below. (Cooling & Heating Model)

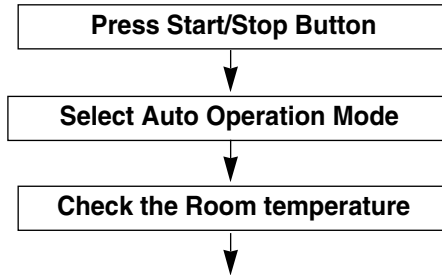

Operation mode Indoor fan speed Setting temperature				are decided automatically by the unit electronic control.
Intake-air temperature	below 70°F	Over 70°F ~ below 76°F	Over 76°F	
Operation Mode	Heating	Soft Dry	Cooling	

* If initial mode is decided, that mode is continued without the room temperature changing.

■ Auto Operation for Cooling

Operation Condition	Intake-air Temperature	Setting Temperature	Fan Speed	Air Direction Control
When Auto Operation initial start	Over 78°F	77°F	Controlled by the electronic control	In this mode, when pressing the vertical air direction control button, vertical louver swings up and down automatically.
	Over 76°F~below 78°F	Intake air -1°C		
	Over 72°F~below 76°F	Intake air -0.5°C		
	Over 68°F~below 72°F	Intake air temperature		
	below 64°F	64°F		
When pressing room temperature setting button during Auto Operation	Over 64°F~below 86°F	Electronic control		
	below 64°F	64°F		
	over 86°F	86°F		

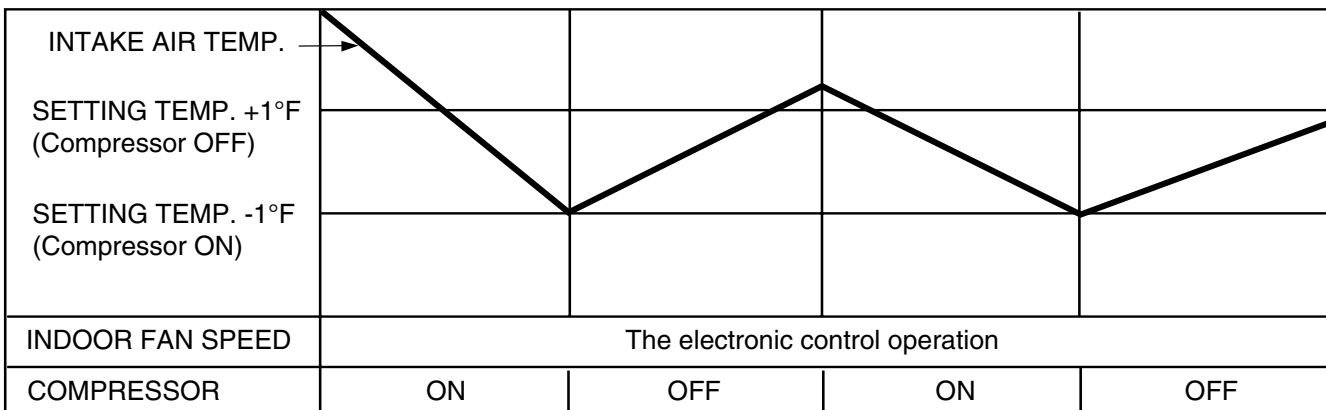

■ Auto Operation for Soft Dry(only Heating Model)

- The Setting temperature will be same that of the auto operation for cooling.
 - Compressor ON temperature; Setting temperature +2°F
 - Compressor OFF temperature; Setting temperture -1°F

Intake-air temp.	below 68°F	Over 68°F~below 70°F	over 86°F
Setting temp.	68°F	Intake air temperature +1°F	86°F

■ Auto Operation for Heating(only Heating Model)

- Compressor ON temperature; Setting temperature
- Compressor OFF temperature; Setting temperature +6°F

■ Vertical louver auto operation : In Auto operation mode, when pressing the vertical airflow direction control button, vertical louver moves as shown below.

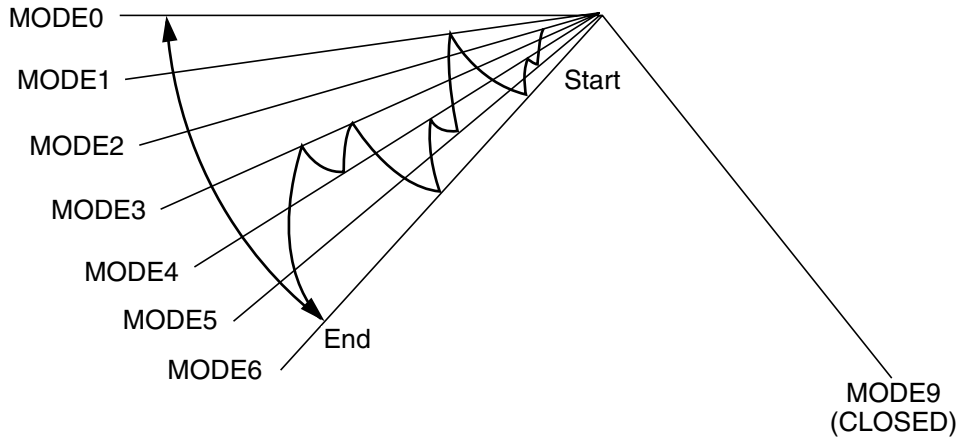

5. Soft Dry Operation Mode

- During Soft Dry Operation, the compressor ON temperature is the setting temperature plus 2°F, the compressor OFF temperature is the setting temperature minus 1°F.
- When the room temperature rises over the compressor ON temperature, the operation mode is switched to the Cooling operation.
- When the room temperature falls between the compressor ON temperature and OFF temperature, the operation mode is switched to the Soft Dry Operation.
- The operation diagram is shown below.

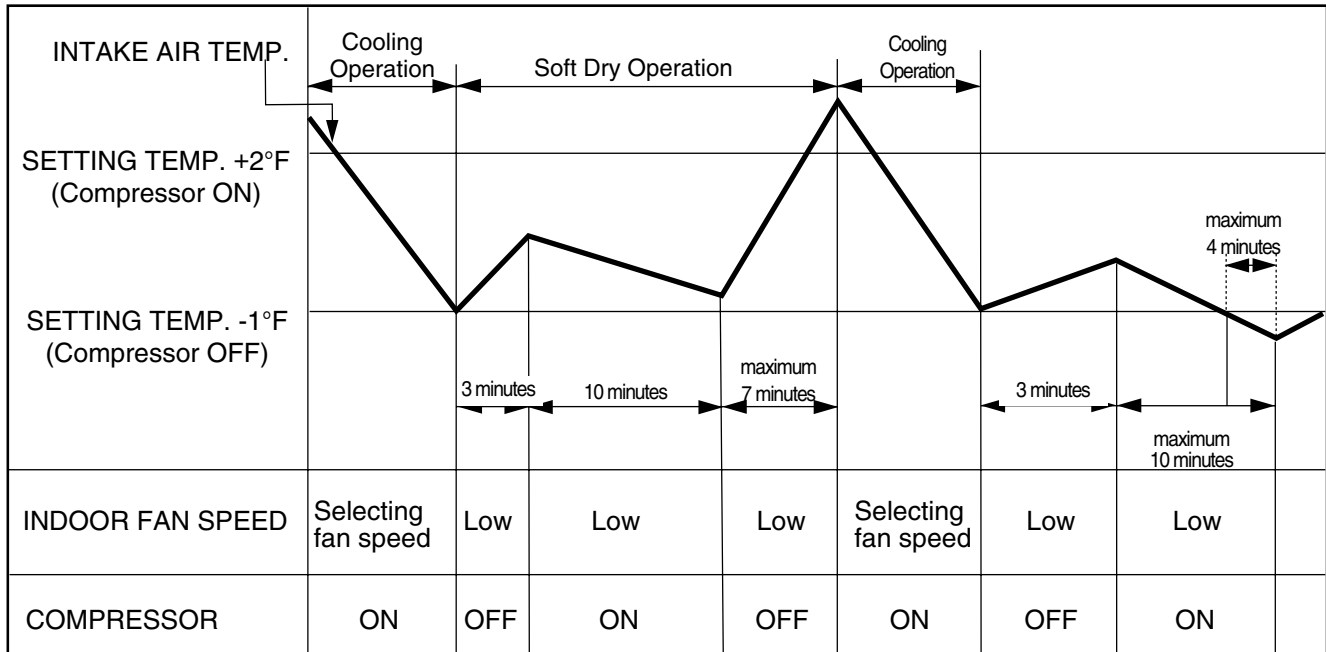

6. Heating Operation Mode(only Heating Model)

The unit will operate according to the setting conditions by the remote controller.
The operation diagram is shown below.

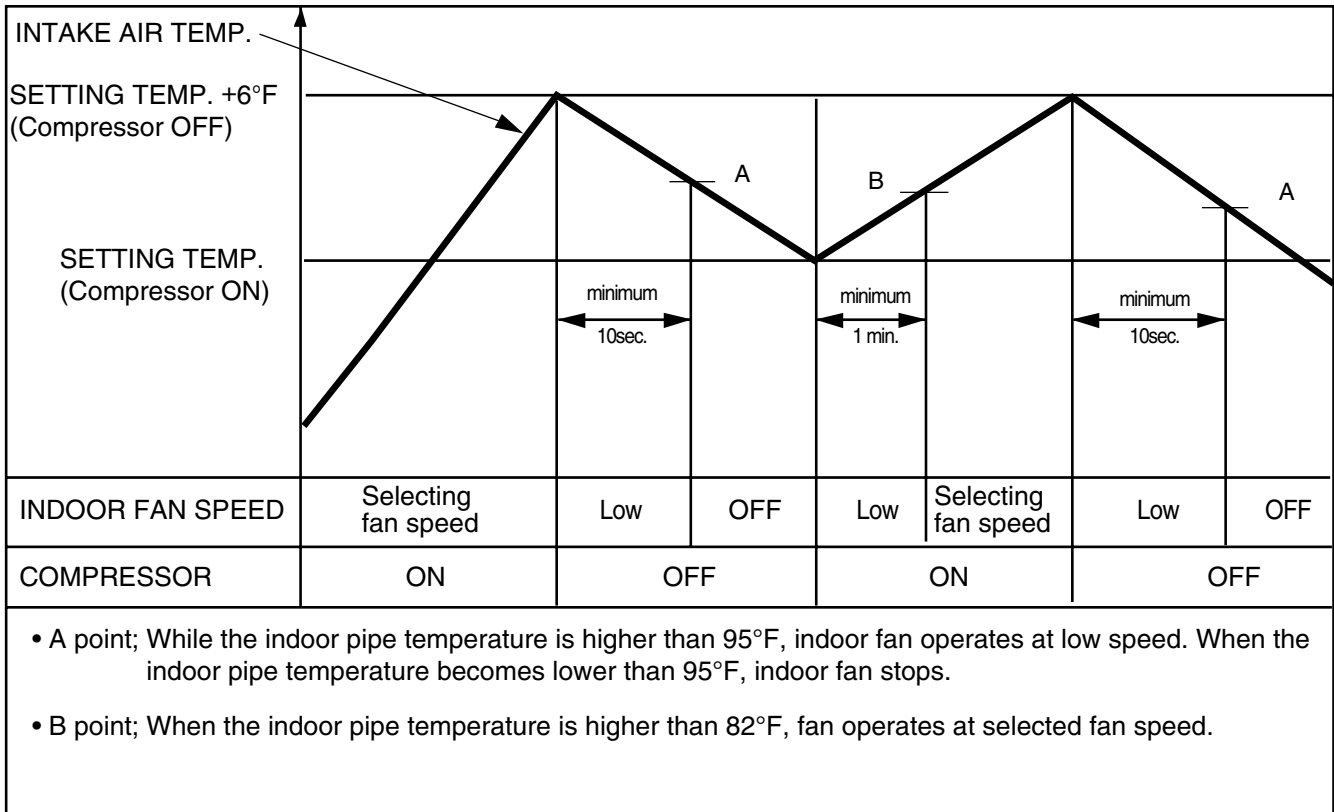

■ Hot-Start Control

- The indoor fan stops until the indoor pipe temperature will be reached at 82°F.
- During heating operation, if indoor pipe temperature falls below 78°F fan stops.
- The operation diagram is shown below.

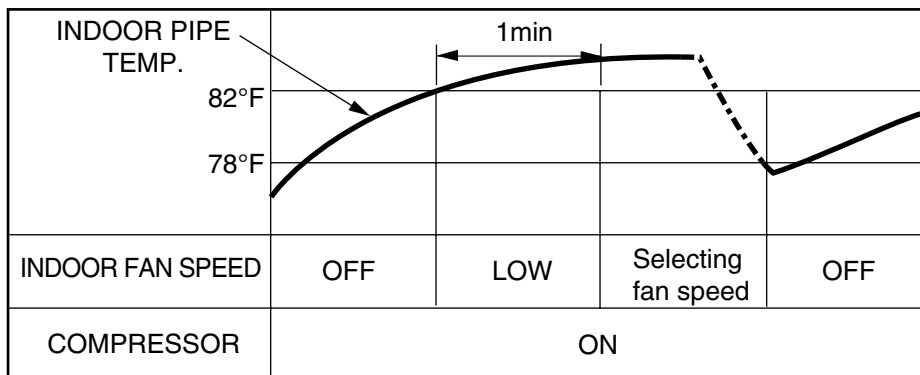

■ Defrost Control

- Defrost operation is controlled by timer and sensing temperature of outdoor pipe.
- The first defrost starts only when the outdoor pipe temperature falls below 21°F after 60 minutes passed from starting of heating operation and more than 10 minutes operation of compressor.
- Defrost ends after 12 minutes passed from starting of defrost operation or when the outdoor fan operates within 4 minutes after the outdoor pipe temperature rises over 54°F even if before 12 minutes.
- The second defrost starts only when the outdoor pipe temperature falls below 21°F after 60 minutes passed from ending of the first defrost and more than 10 minutes operation of compressor.

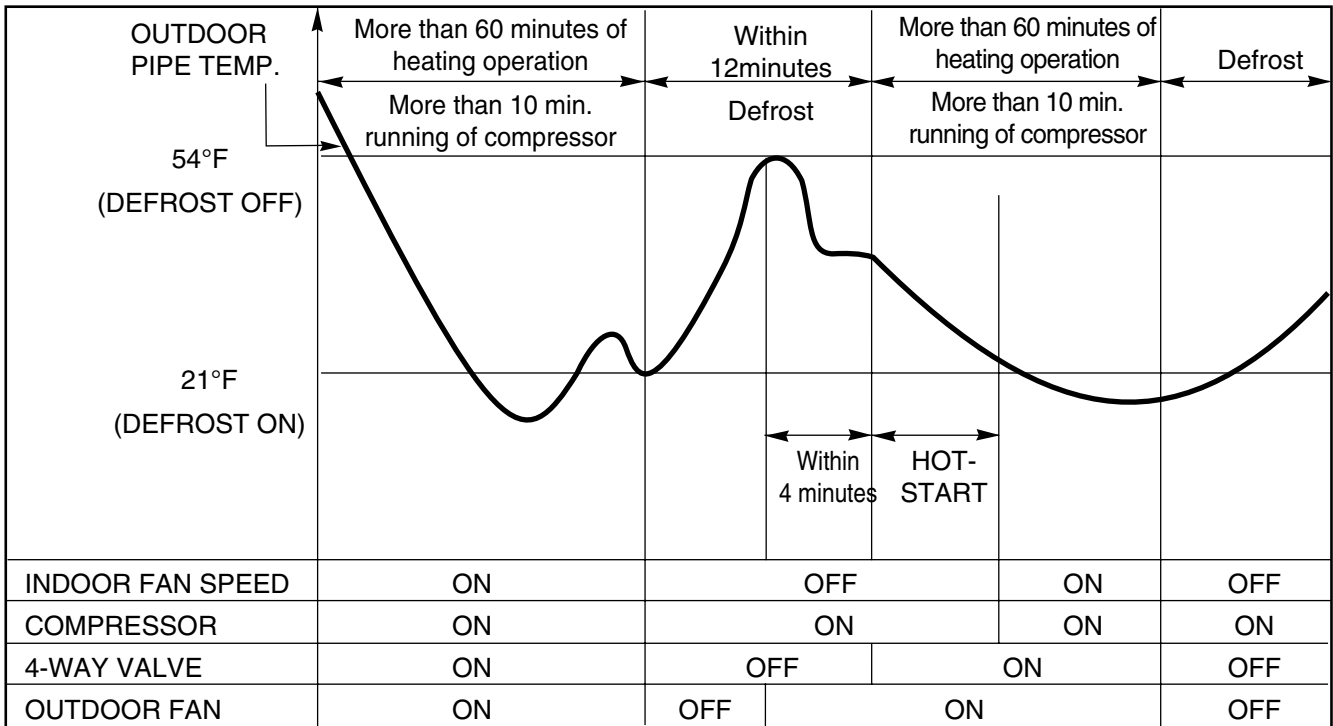

7. Cooling or Heating Mode with Sleep Mode Auto Control

- When selecting the Cooling(✱) or the Heating(✨) combined with the Sleep Mode Auto Control(☆), the operation diagram is as following.

■ Cooling Mode with the Sleep Mode

- The setting temperature will be automatically raised by 2°F 30 minutes later and by 4°F 1 hour later.
- The operation will be stopped after 1, 2, 3, 4, 5, 6, 7 hours.

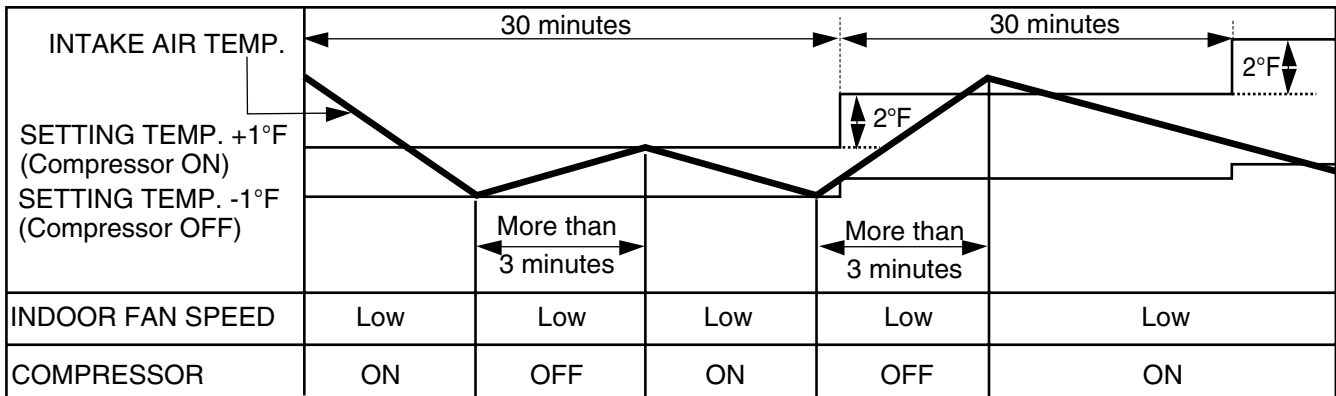

■ Heating Mode with the Sleep Mode(only Heating Model)

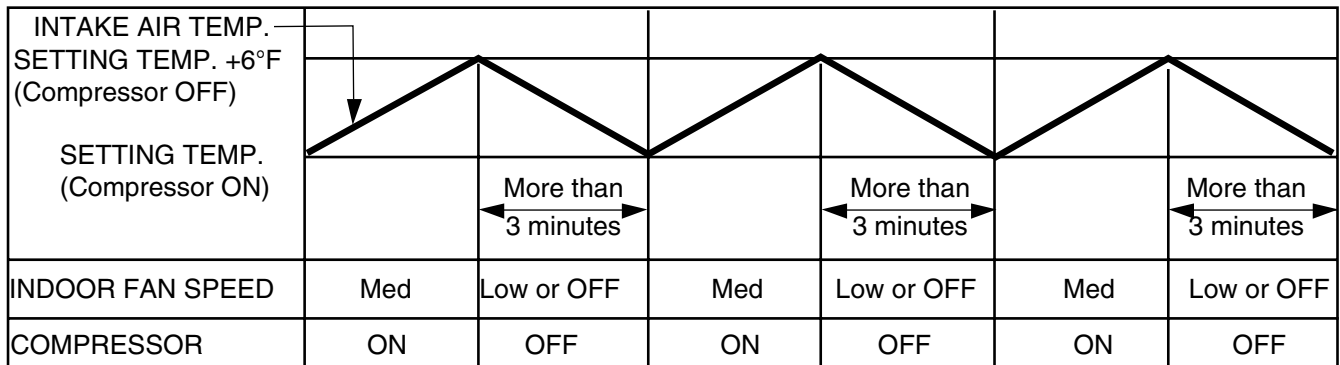

8. Forced Operation

- If you lose wireless remote controller, you can operate the unit with forced operation button.
- The standard conditions are shown below.

	Cooling Model	Heating Model		
		Room Temp $\geq 76^{\circ}\text{F}$	$70^{\circ}\text{F} \leq \text{Room Temp} < 76^{\circ}\text{F}$	Room temp $< 70^{\circ}\text{F}$
Operation Mode	Cooling	Cooling	Soft Dry	Heating
Indoor Fan Speed	High	High	Soft Dry Rule	High
Setting Temp.	72°F	72°F	74°F	76°F

- Unit operates in low fan speed for first 15 seconds, then switched to proper operation mode according to intake air temperature.

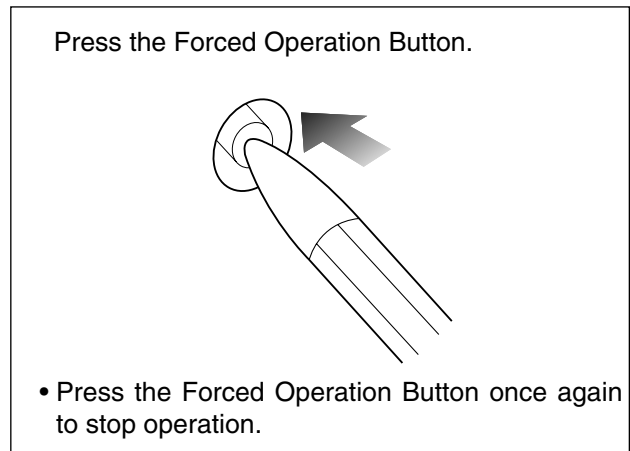
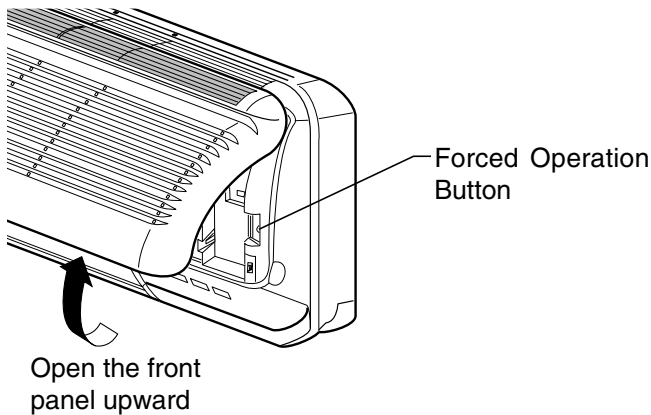

9. Crank Case Heater Coil Control(only Heating model)

- When the power is applied to the set, the heater operates unconditionally.
- Except for the heating mode operation, the heater is always to be off.
- During the heating mode operation, the heater and compressor are operated by turns.
(Compressor ON \rightarrow Heater OFF, Compressor OFF \rightarrow Heater ON)

Test Mode

Test operation will be set by pushing the "Test key" on the main PWB Assy. Each test operation by pushing count of "Test key" is as well as the following.

(1) Indoor

- Once push : Ignore communication error.
- Twice push : Shorten the proceeding time.(1min → 1sec)
- 3 Times push : Shorten the proceeding time.(1hour → 1sec)
- 4 Times push : All LED ON
- 5 Times push : Up/Down Step Motor ON.
- 6 Times push : Right Step Motor ON. (Not on all Models)
- 7 Times push : Left Step Motor ON.(Not on all Models)
- 8 Times push : Negative Ion ON.(Not on all Models)
- 9 Times push : Reset.

Note)

For normal operation after checking by test mode, you should reset main power.

(2) Outdoor

- Once push : Ignore Communication error.
- Twice push : Comp. ON, Outdoor Fan ON
Reversing Valve Coil ON(only Heating Model)
Crank Case heater Coil ON(only Heating Model)
- 3 Times push : Comp. ON, Outdoor Fan ON
Reversing Valve Coil OFF(only Heating Model)
Crank Case Heater Coil OFF(only Heating Model)
- 4 Times push : Same
- 5 Times push : Error LED(Red) ON
- 6 Times push : Comp OFF, Outdoor FAN OFF
- 7 Times push : Reset

Note)

For normal operation after checking by test mode, you should reset main power.

Display Function

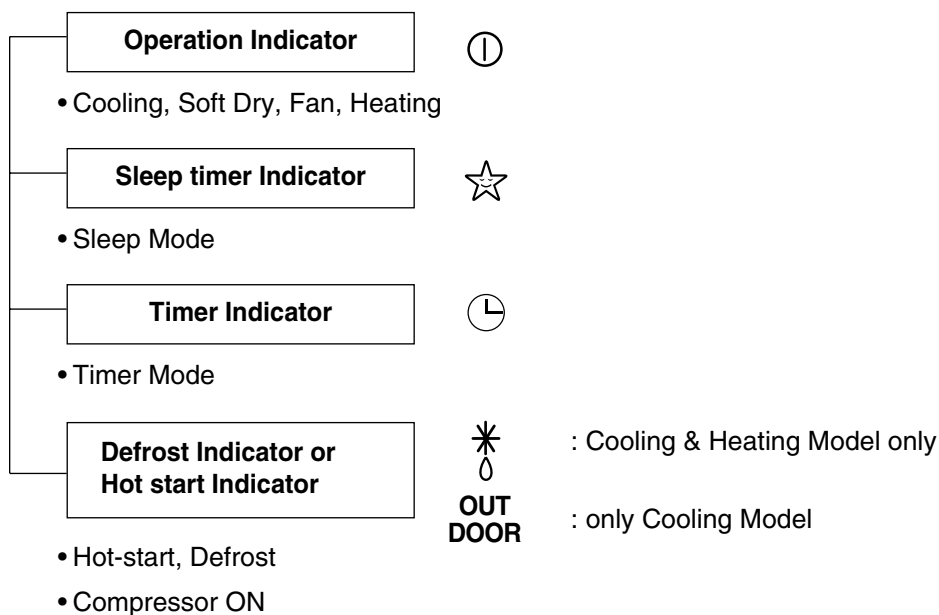

• BUZZER SOUND

- Power Input or Reset : One short beep.
- When Operation Stop Button is pressed : One long beep.
- When Remote Controller Buttons except for Operation Stop are pressed : Two short beep.
- When Forced Operation Button is pressed : Two Short beep.

Self-diagnosis Function

CODE NO.	DIAGNOSIS	Operation Indicator LED Blinks	Unit Operation
①	Indoor room temperature thermistor or pipe temperature thermistor Short/Open	Once	Still Operation
②	Outdoor pipe thermistor Short/Open	Twice	Outdoor Unit Off
③	Communication failure between indoor and outdoor	5 times	Stop
\	Indoor fan locked	8 times	Stop

- LED blinks as many times as code No. (0.5 second ON/0.5 second OFF) with 3 seconds interval.
- While the unit is off, no indication displays.
- If more than one code occurs simultaneously, bigger code No. is displayed.

Installation

IMPORTANT!

Please read this instruction sheet completely before installing the product.

This air conditioning system meets strict safety and operating standards. As the installer or service person, it is an important part of your job to install or service the system so it operates safely and efficiently.

WARNING

- Installation or repairs made by unqualified persons can result in hazards to you and others. Installation MUST conform with local building codes or, in the absence of local codes, with the National Electrical Code NFPA 70/ANSI C1-1993 or current edition and Canadian Electrical Code Part 1 CSA C.22.1.
- The information contained in the manual is intended for use by a qualified service technician familiar with safety procedures and equipped with the proper tools and test instruments.
- Failure to carefully read and follow all instructions in this manual can result in equipment malfunction, property damage, personal injury and/or death.

CAUTION: Improper installation, adjustment, alteration, service or maintenance can void the warranty.

The weight of the condensing unit requires caution and proper handling procedures when lifting or moving to avoid personal injury. Use care to avoid contact with sharp or pointed edges.

Safety Precautions

- Always wear safety eye wear and work gloves when installing equipment.
- Never assume electrical power is disconnected. Check with meter and equipment.
- Keep hands out of fan areas when power is connected to equipment.
- R-22 causes frostbite burns.
- R-22 is toxic when burned.

NOTE TO INSTALLING DEALER: The Owners Instructions and Warranty are to be given to the owner or prominently displayed near the indoor Furnace/Air Handler Unit.

Special warnings

When wiring:

Electrical shock can cause severe personal injury or death. Only a qualified, experienced electrician should attempt to wire this system.

- Do not supply power to the unit until all wiring and tubing are completed or reconnected and checked.
- Highly dangerous electrical voltages are used in this system. Carefully refer to the wiring diagram and these instructions when wiring. Improper connections and inadequate grounding can cause accidental injury or death.
- Ground the unit following local electrical codes.
- Connect all wiring tightly. Loose wiring may cause overheating at connection points and a possible fire hazard.

When transporting:

Be careful when picking up and moving the indoor and outdoor units. Get a partner to help, and bend your knees when lifting to reduce strain on your back. Sharp edges or thin aluminum fins on the air conditioner can cut your finger.

When installing...

... **in a wall:** Make sure the wall is strong enough to hold the unit's weight.

It may be necessary to construct a strong wood or metal frame to provide added support.

... **in a room:** Properly insulate any tubing run inside a room to prevent "sweating" that can cause dripping and water damage to wall and floors.

... **in moist or uneven locations:** Use a raised concrete pad or concrete blocks provide a solid, level foundation for the outdoor unit. This prevents water damage and abnormal vibration.

... **in an area with high winds:** Securely anchor the outdoor unit down with bolts and a metal frame. Provide a suitable air baffle.

... **in a snowy area(for Heat Pump Model):** Install the outdoor unit on a raised platform that is higher than drifting snow. Provide snow vents.

When connecting refrigerant tubing

- Keep all tubing runs as short as possible.
- Use the flare method for connecting tubing.
- Check carefully for leaks before starting the test run.

When servicing

- Turn the power OFF at the main power box(mains) before opening the unit to check or repair electrical parts and wiring.
- Keep your fingers and clothing away from any moving parts.
- Clean up the site after you finish, remembering to check that no metal scraps or bits of wiring have been left inside the unit being serviced.

(1) Installation Parts Provided

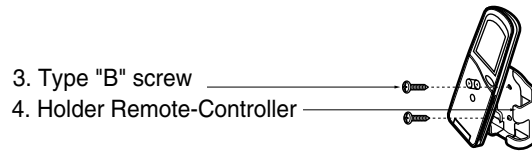
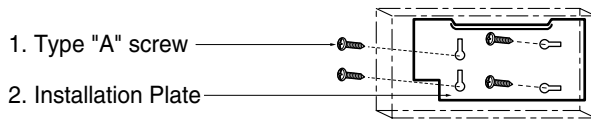

(2) Installation of Indoor, Outdoor unit

1) Selection of the best location

1. Indoor unit.

- There should not be any heat source or steam near the unit.
- There should not be any obstacles to prevent the air circulation.
- A place where air circulation in the room will be good.
- A place where drainage can be easily obtained.
- A place where noise prevention is taken into consideration.
- Do not install the unit near the door way.
- Ensure the spaces indicated by arrows from the wall, ceiling, fence, or other obstacles.

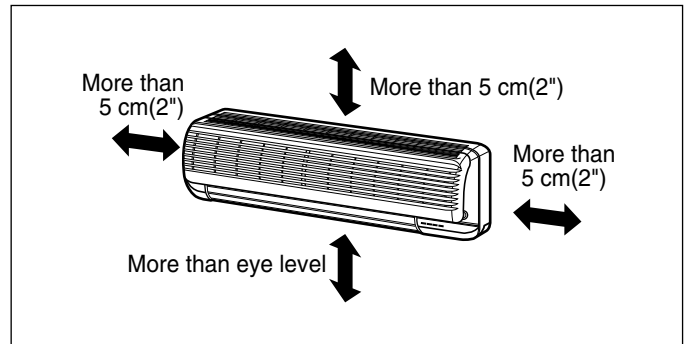

2. Outdoor unit

- If an awning is built over the unit to prevent direct sunlight or rain exposure, be careful that heat radiation from the condenser is not restricted.
- There should not be any animals or plants which could be affected by hot air discharged.
- Ensure the spaces indicated by arrows from the wall, ceiling, fence, or other obstacles.

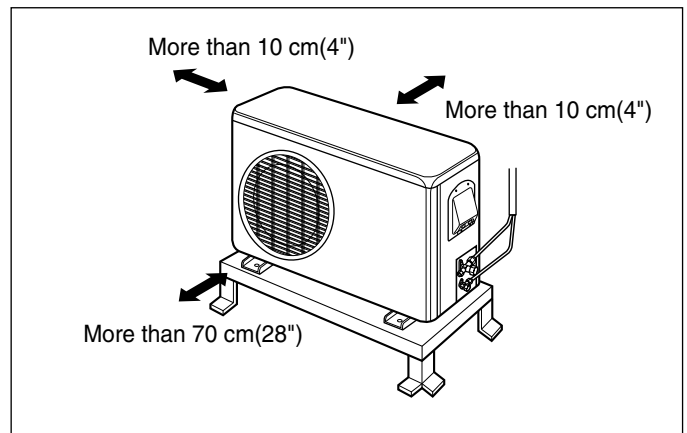

Roof Top Installations

If it is necessary to install units on a roof structure, be sure to elevate and level the units. Ensure the roof structure and anchoring method are adequate for unit location. Consult local codes regarding rooftop mounting.

NOTE: When condensing unit is to be installed on a bonded guaranteed roof, a release must be obtained from the building owner to free the installer from all liabilities.

3. Piping length and the elevation

MODEL (Cooling Capa.)	Pipe Size		Max. length A	Max. Elevation B
	GAS	LIQUID		
9k, 12k	1/2"	1/4"	15m(50ft)	8m(26ft)
18k, 24k	5/8"	3/8"	15m(50ft)	8m(26ft)

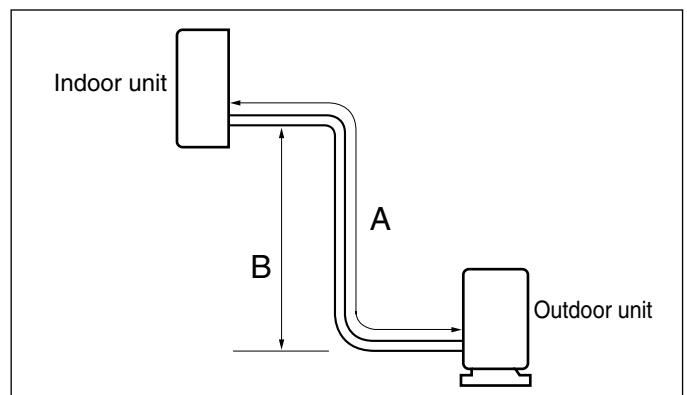

2) Indoor Unit Installation

The mounting wall should be strong and solid enough to protect it from the vibration.

1. Mount the installation plate on the wall with four Type "A" screws.

(if mounting the unit on the concrete wall, consider using anchor bolts.)

- Always mount the Installation Plate horizontally by aligning the marking-off line by means of the thread and a level.

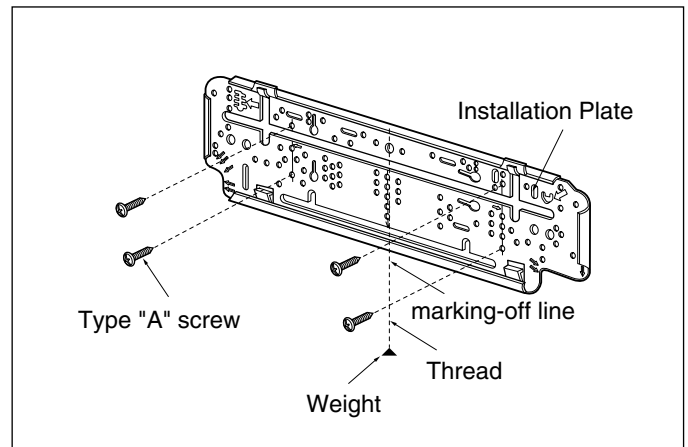

2. Drill the piping hole with 70mm(2.75") dia. holecore drill.

- Drill the Piping hole at either the right or the left and the hole should be slightly slanted to the outdoor side.

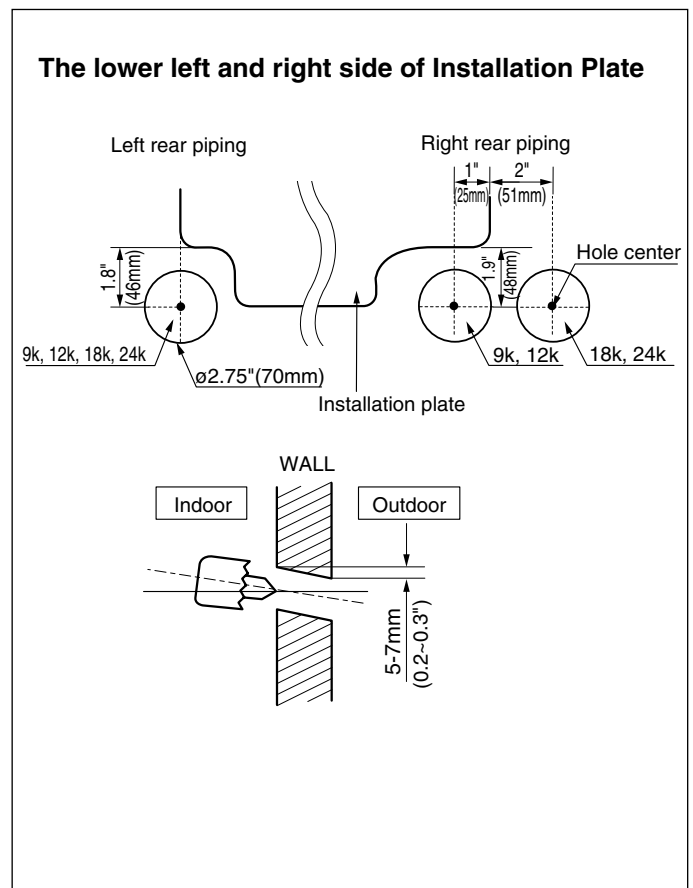

WARNING

Avoid areas where electrical wiring, conduits or gas lines are located. Accidentally cutting a live wire or gas line can cause death or injury.

(3) Piping and Drainage of Indoor Unit

1) PREPARATION OF PIPINGS

1. Cut the pipes and the cable.

- Use the pipes purchased locally.
- Measure the distance between the indoor and the outdoor unit.
- Cut the pipes a little longer than measured distance.
- Cut the cable 1.5m(5.0 ft) longer than the length of the pipe.

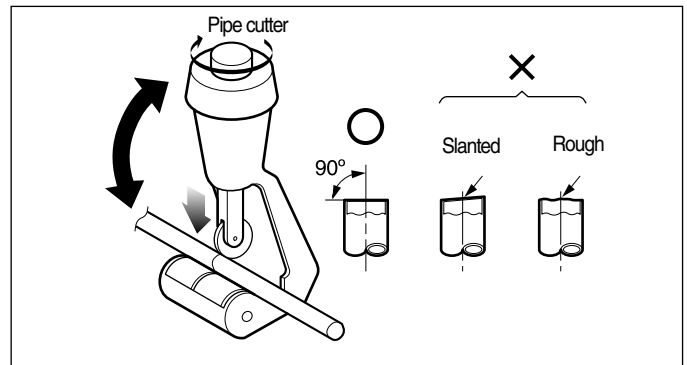

2. Remove burrs.

- Remove burrs from cut edges of pipes.
- Turn the pipe end toward down to avoid the metal powder entering the pipe.

Caution:

If burrs are not removed, they may cause a gas leakage.

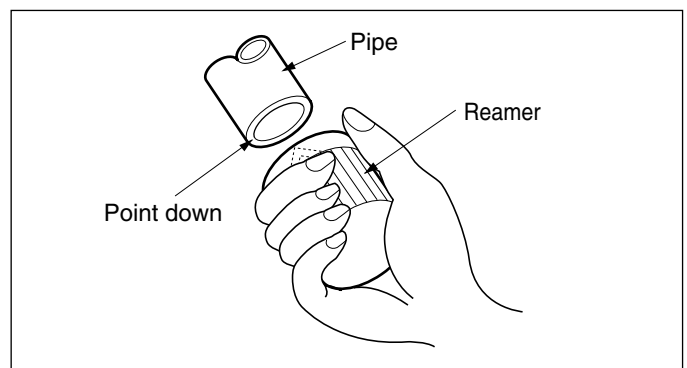

3. Flaring the pipes.

- Make a flare at the end of copper pipe with a flare tool*. (See illustration)
- Tubing to be flared should extend slightly above flaring block to allow sufficient metal to form satisfactory flare. Amount to allow is about a third of the height of flare.

A : Proper position of tube in flaring tool before flaring.

B : Completed flare.

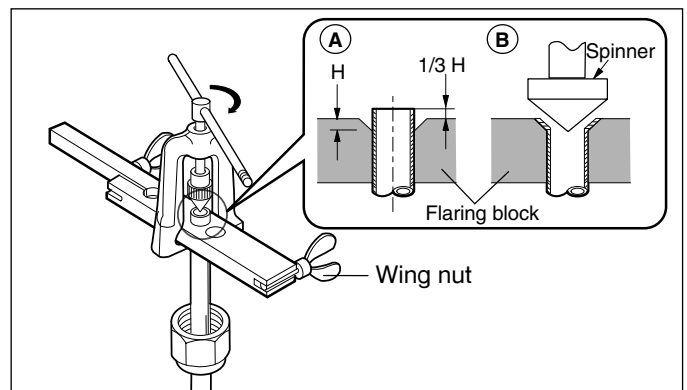

4. Tape the flaring portion to protect it from the dust or damages.

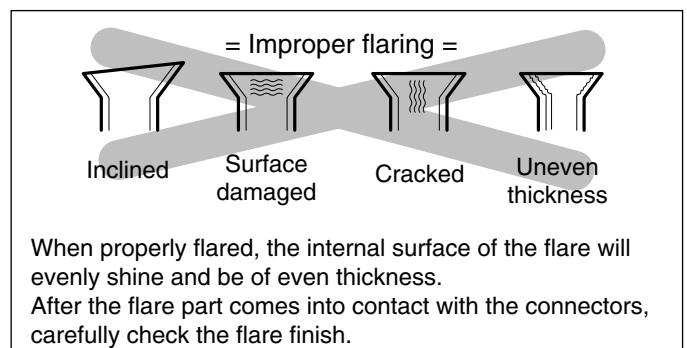

2) Connection of Pipings

1. Remove the indoor tubing with Drain hose from the hole

- Remove tubing holder and pull the tubing out of the chassis.

2. Replace the tubing holder into original position.

- Recommended SPEC. of a additional Drain Hose.

Joint Part		The material of Drain hose
Inner size	Material	
MAX. ø16mm(5/8")	soft PVC	Soft PVC hose (It must be surrounded with an Insulation Material*)

- * Foamed Polyethylene or equivalent is recommended.

CAUTION: The unit's drain hose and additional drain hose must be sealed up by adhesive or tape.

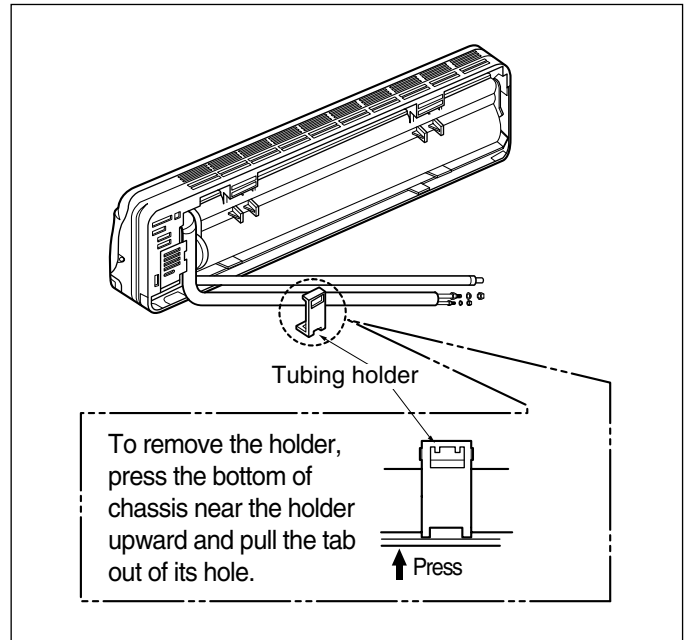

For right rear piping

3. Route the tubing and the drain hose straight backwards.

4. Insert the connecting cable into the indoor unit through the piping hole.

- Do not connect the cable to the indoor unit.
- Make a small loop with the cable for easy connection later.

5. Tape the tubing, drain hose and the connecting cable. Be sure that drain hose locates at the lowest side of the bundle. Locating at the upper side can be a reason that drain water overflows drain pan inside the unit.

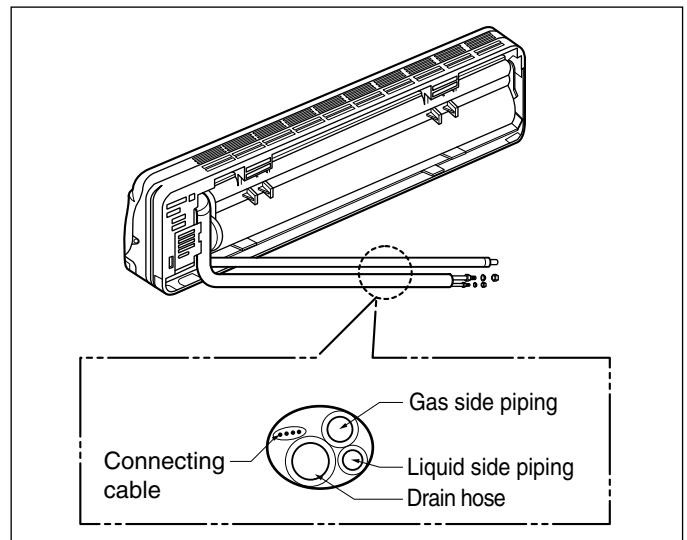

NOTE

If the drain hose will run in the room, insulate the hose with an insulation material* so that dripping from "sweating"(condensation) will not damage furniture or floors.

- * Foamed polyethylene or equivalent is recommended.

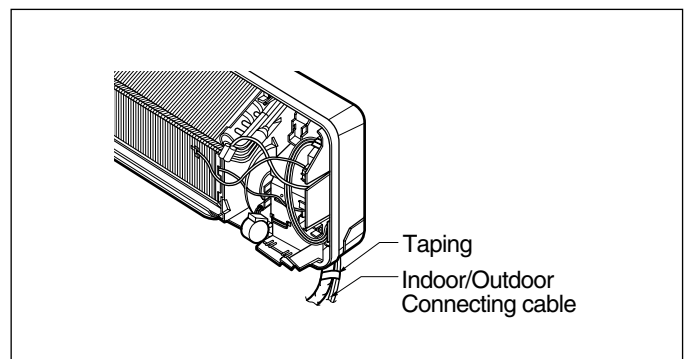

6. Indoor unit installation

- Hook the indoor unit onto the upper portion of installation plate. (Engage the two hooks of the rear top of the indoor unit with the upper edge of the installation plate.)

Ensure the hooks are properly seated on the installation plate by moving it left and right.

7. Connecting the pipings to the indoor unit.

- Align the center of the pipings and sufficiently tighten the flare nut with fingers.
- Finally, tighten the flare nut with torque wrench until the wrench clicks. When tightening the flare nut with torque wrench, ensure the direction for tightening follows the arrow on the wrench.

Pipe Size		Torque
9k, 12k	Liquid Side (1/4")	1.8kg·m(13ft.lbs)
	Gas Side (1/2")	5.5kg·m(39.8ft.lbs)
18k, 24k	Liquid Side (3/8")	4.2kg·m(28.9ft.lbs)
	Gas Side (5/8")	6.6kg·m(47.7ft.lbs)

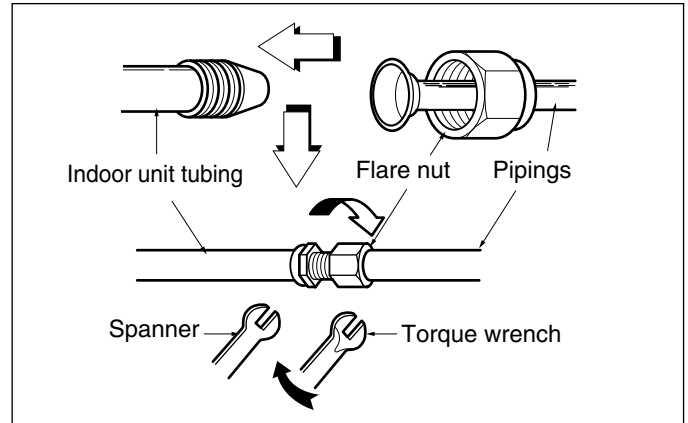
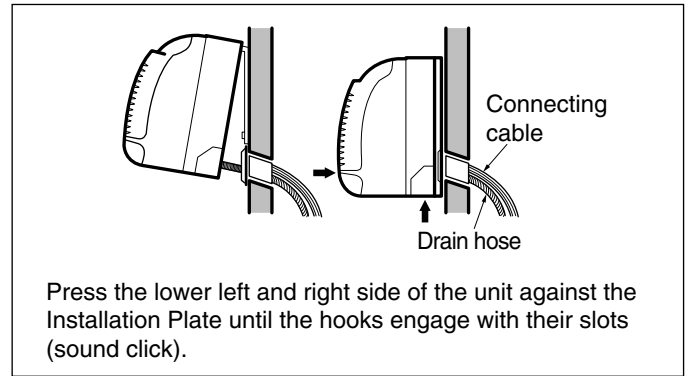

8. Wrap the insulation material around the connecting portion.

CAUTION: Take care to arrange the pipings, drain hose and cables as the picture on page 25 for inserting it into the indoor unit and refixing the tubing holder easily.

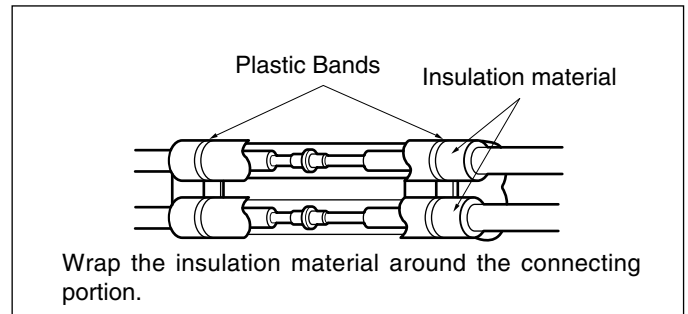

9. Insulation of connecting tubing

- Because capillary tubing is installed in the outdoor unit, both the liquid and gas side tubes of this air conditioner become cold or hot(Heat pump model). Therefore, to prevent heat loss and wet floors due to dripping of condensation water, both tubes must be well insulated with proper insulation material. The thickness of the insulation material should be a Min. 8mm(5/16").

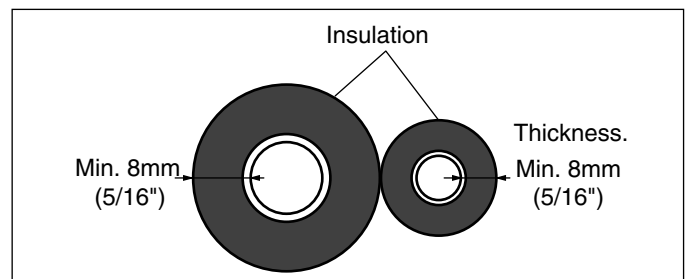

For Heat pump model, Heat-resistant insulation material enduring at 230°F should be used.

For the left pipings

3. Route the indoor tubing with the drain hose to the piping hole as desired position.

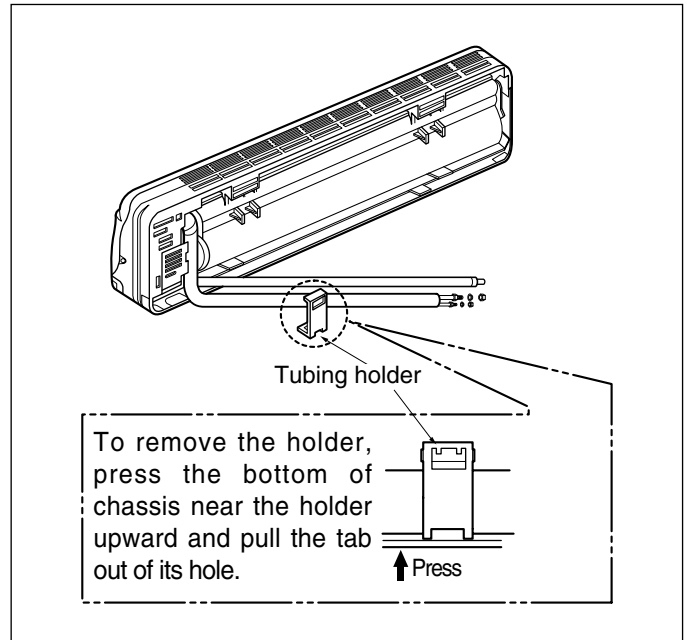

4. Insert the pipings, power supply cord and connecting cable into the piping hole.

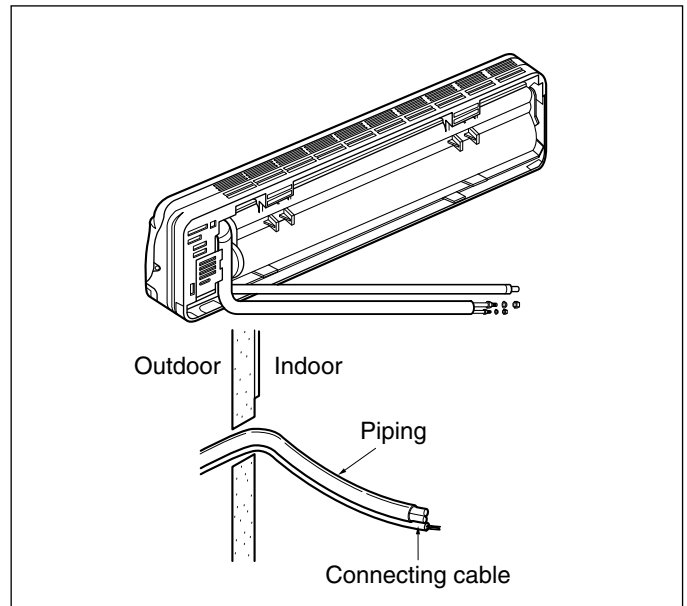

5. Insert the connecting cable into the indoor unit.

- Don't connect the cable to the indoor unit.
- Make a small loop with the cable for easy connection later.

6. Tape the tubing, drain hose and the connecting cable.

7. Indoor unit installation

- Hook the indoor unit onto the upper portion of installation plate. (Engage the two hooks of the rear top of the indoor unit with the upper edge of the installation plate.)
Ensure the hooks are properly seated on the installation plate by moving it in left and right.

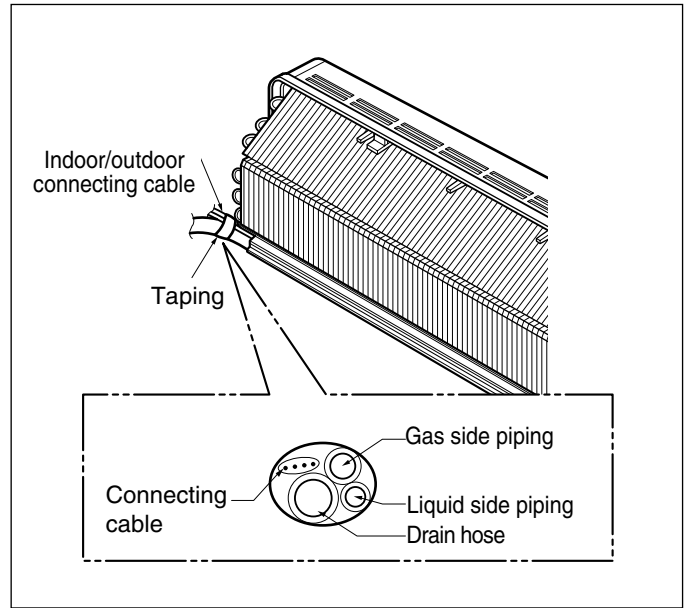

8. Connecting the pipings to the indoor unit.

- Align the center of the pipings and sufficiently tighten the flare nut with fingers.
- Finally, tighten the flare nut with torque wrench until the wrench clicks.
When tightening the flare nut with torque wrench, ensure the direction for tightening follows the arrow on the wrench.

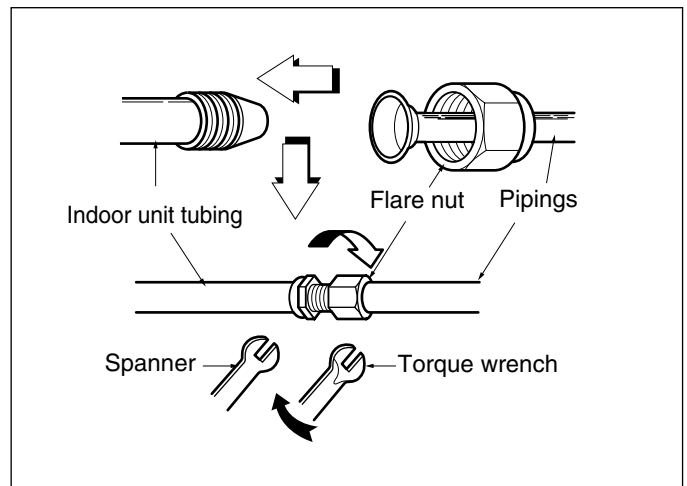

Pipe Size		Torque
9k, 12k	Liquid Side (1/4")	1.8kg·m(13ft.lbs)
	Gas Side (1/2")	5.5kg·m(39.8ft.lbs)
18k, 24k	Liquid Side (3/8")	4.2kg·m(28.9ft.lbs)
	Gas Side (5/8")	6.6kg·m(47.7ft.lbs)

9. Wrap the insulation material around the connecting portion.

CAUTION: Take care to arrange the pipings, drain hose and cables as the right upper picture for inserting it into the indoor unit and refixing the tubing holder easily.

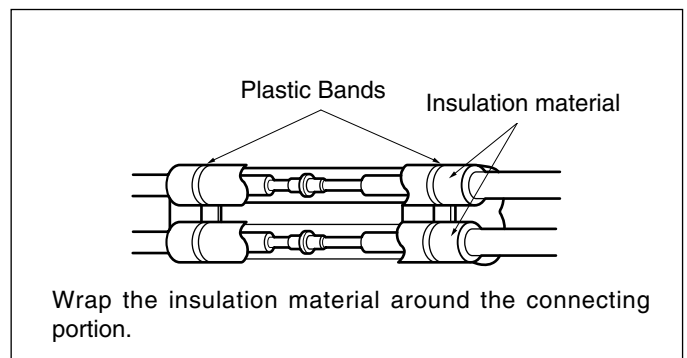

10. Set the pipings and the connecting cable to the back of the chassis with the tubing holder

- Hook the edge of tubing holder to tap on chassis and push the bottom of tubing holder to be engaged in the bottom of chassis.

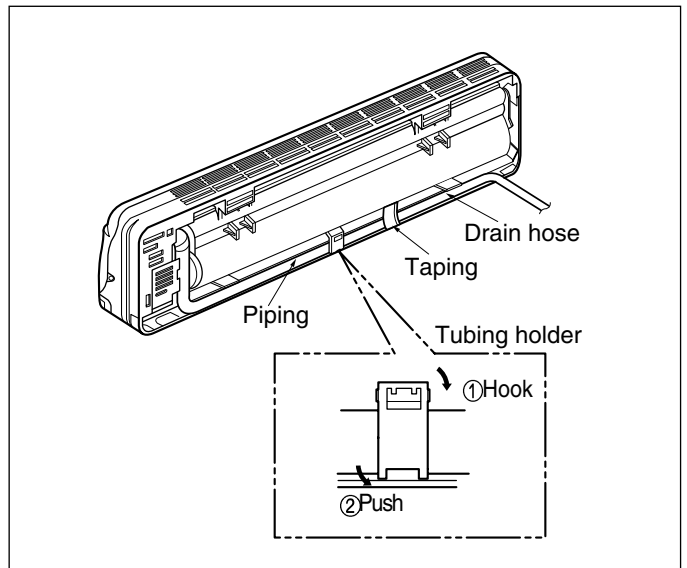
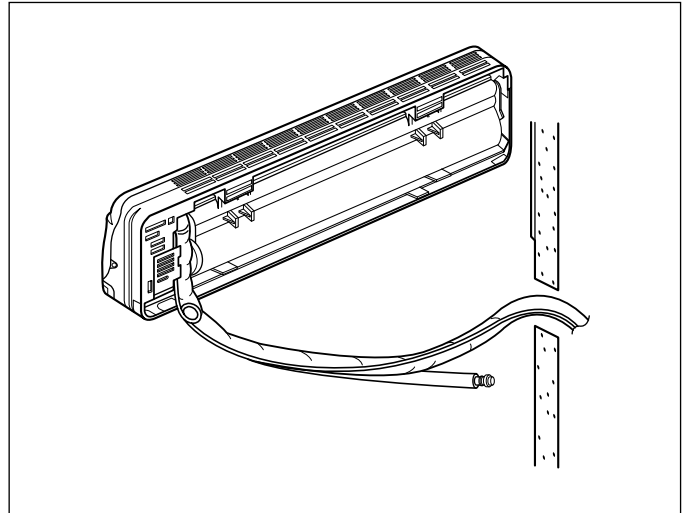

11. Indoor unit installation

- Hook the indoor unit onto the upper portion of installation plate. (Engage the two hooks of the rear top of the indoor unit with the upper edge of the installation plate.)
Ensure the hooks are properly seated on the installation plate by moving it in left and right.

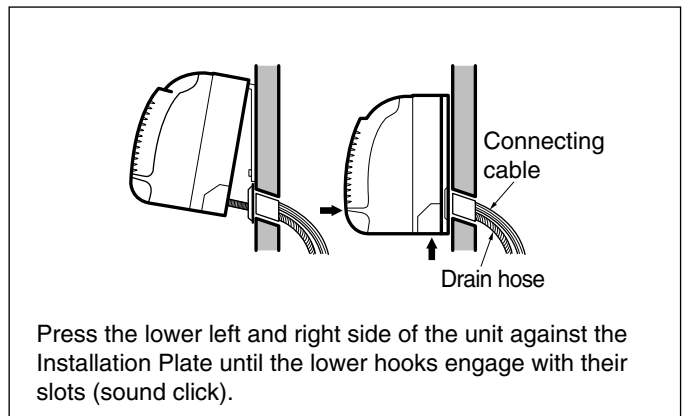

(4) Connecting Pipings and the cable to Outdoor unit

1) Connecting the pipings to the Outdoor unit

1. Align the center of the pipings and sufficiently tighten the flare nut with fingers.
2. Finally, tighten the flare nut with torque wrench until the wrench clicks.
 - When tightening the flare nut with torque wrench, ensure the direction for tightening follows the arrow on the wrench.

Pipe Size		Torque
9k, 12k	Liquid Side (1/4")	1.8kg·m(13ft.lbs)
	Gas Side (1/2")	5.5kg·m(39.8ft.lbs)
18k, 24k	Liquid Side (3/8")	4.2kg·m(28.9ft.lbs)
	Gas Side (5/8")	6.6kg·m(47.7ft.lbs)

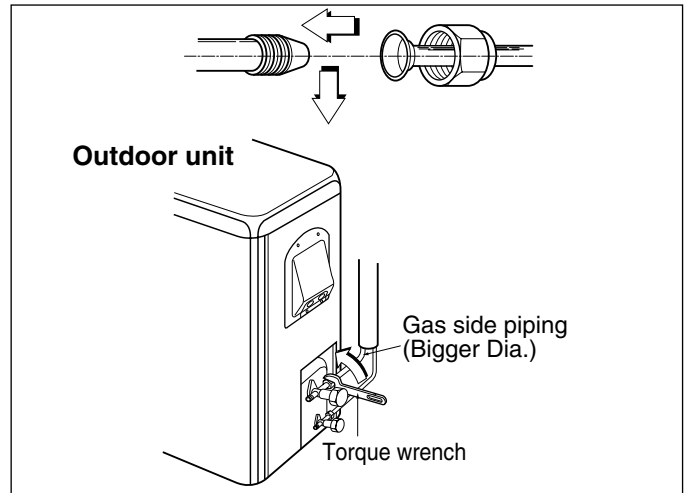

2) Connection of the cable

1. Remove the control cover from the unit by loosening the 3 screws.
2. Dismount caps on the conduit panel.
3. Temporarily mount the conduit tubes on the conduit panel.
4. Properly connect both the power supply and low voltage lines to the corresponding terminals on the terminal block.
5. Ground the unit in accordance with local codes.
6. Be sure to size each wire allowing several inches longer than the required length for wiring.
7. Use lock nuts to secure the conduit tubes.

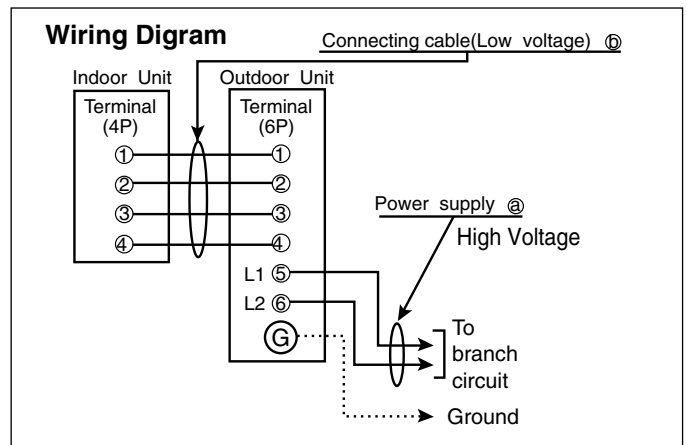

NOTE

Connector trade size for this unit is 1/2".
Refer to "How to connect wiring to the terminals" for instructions on connecting depending on the wire type you are using.



WARNING

- Be sure to comply with local codes while running the wire from the indoor unit to the outdoor unit (size of wire and wiring method, etc).
- Every wire must be connected firmly.
- No wire should be allowed to touch refrigerant tubing, the compressor or any moving parts.

NOTE

1. shows field wiring.
2. Separately wire the high and low voltage line.
3. Use heat-proof electrical wiring capable of withstanding temperatures up to 167°F.
4. Use outdoor and waterproof connection cable rated more than DC 100V/3A for the connection between indoor and outdoor unit.

Power Supply

Model	Power source	AWG(MIN.)		Fuse or breaker Capacity
		Ⓐ	Ⓑ	
9k, 12k	1φ, 115V	14	18	15A
18k	1φ, 230/208V	14	18	15A
24k	1φ, 230/208V	14	18	20A

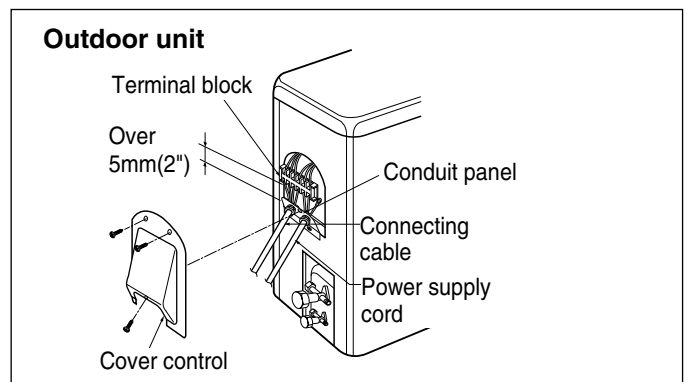

Connection method of the connecting cable(Example)

- (1) Dismount two-caps on the conduit panel.
- (2) Make a hole appropriate for the passage of connection cable through on cap by tool.
(for low voltage line)
- (3) Pass the connecting cable through the hole.
- (4) Properly connect the cable on the terminal block.
- (5) Fix the connection cable with clamp cord provided on the unit not to have strain at the terminal when the connection cable is pulled outside up to a 35 pound weight.
- (6) Wind the vinyl tape round the connecting cable for sealing between the surface of the connection cable and cap.
- (7) Mount the taped part of cable on the cap.
- (8) Finally, mount the holed cap with the wound cable on the conduit panel.



WARNING

Loose wiring may cause the terminal to overheat or result in unit malfunction. A fire hazard may also exist. Therefore, be sure all wiring is tightly connected.

When connecting each power wire to the corresponding terminal, follow instructions "How to connect wiring to the terminals" and fasten the wire tightly with the fixing screw of the terminal plate.

■ For strand wiring

- (1) Cut the wire end with a wire cutter or wire-cutting pliers, then strip the insulation to expose the strand wiring about 10mm(3/8").
- (2) Using a screwdriver, remove the terminal screw(s) on the terminal plate.
- (3) Using a round terminal fastener or pliers, securely clamp each stripped wire end with a round terminal.
- (4) Position the round terminal wire, and replace and tighten the terminal screw using a screwdriver.

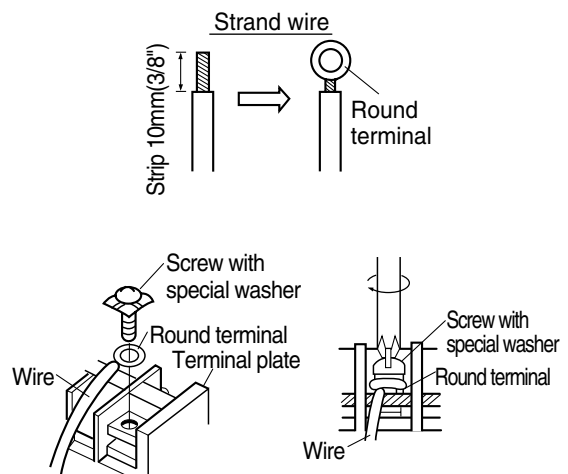
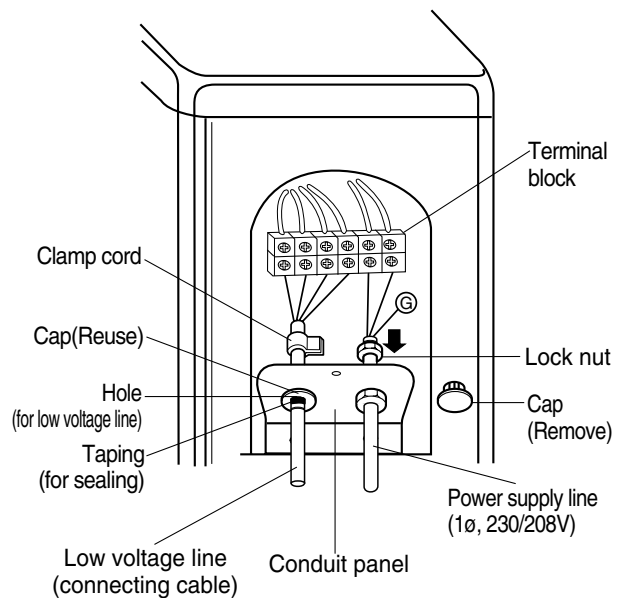

(5) Checking the Drainage and Connecting the cable to Indoor unit

1) Checking the Drainage

1. Remove the Grille from the cabinet.

- Set the up-and-down air direction louver to open position (horizontally) by finger pressure.
- Remove 3 screws.
- To remove the Grille, pull lower the left and right side of the grille toward you (slightly tilted) and lift it straight upward (Four tabs on the top inside edge of chassis are clear of their slots).

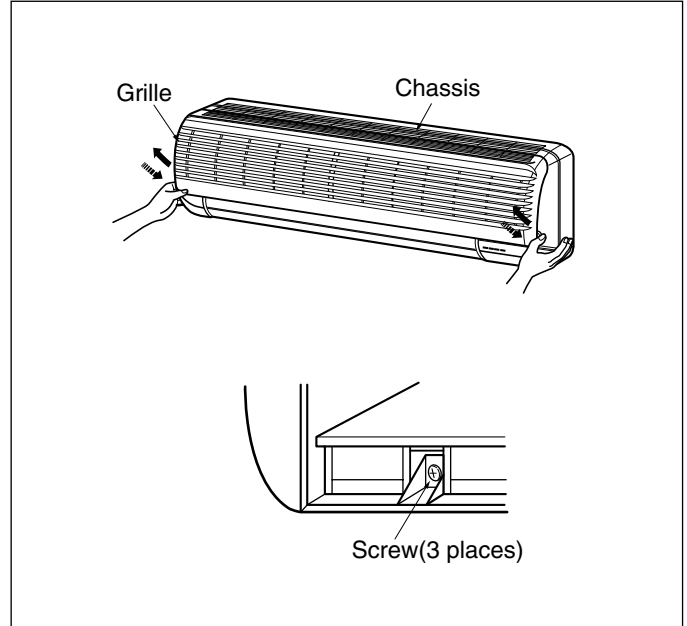

NOTE

- Outside drain hose should be lower than inside.
- The end of drain hose should not come in touch with surface of land.
- The end of drain hose should not dip into sewer or water.

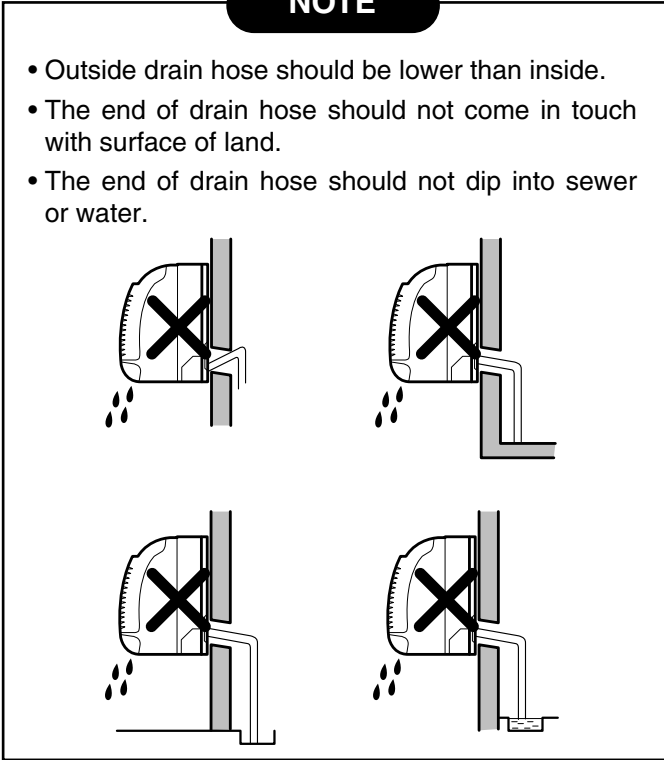

2. Check the drainage.

- Pour a glass of water on the evaporator.
- Ensure if water flows drain hose of indoor unit without any leakage.

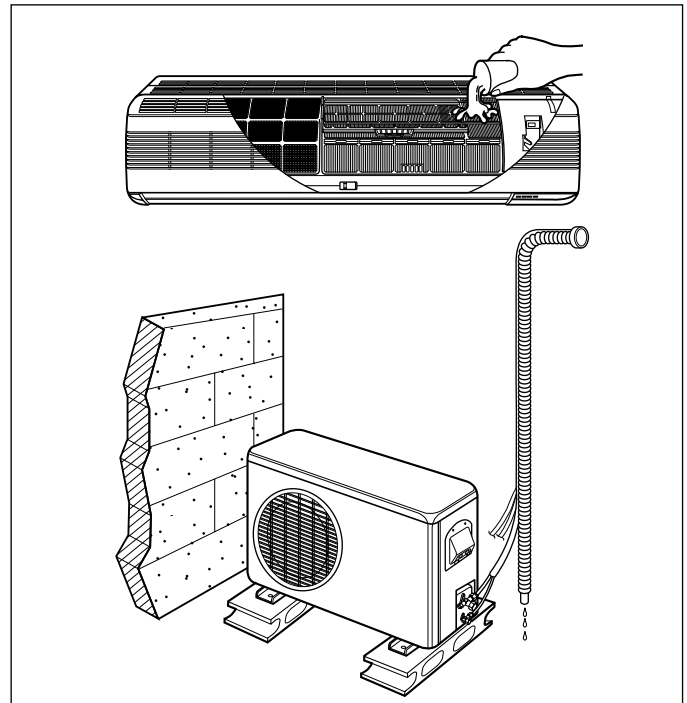

2) Connect the cable to the indoor unit

1. Connect the wires to the terminals on the control board individually according to the outdoor unit connection.

- Ensure that the color of the wires of outdoor unit and the terminal No. are the same as those of indoor unit respectively.

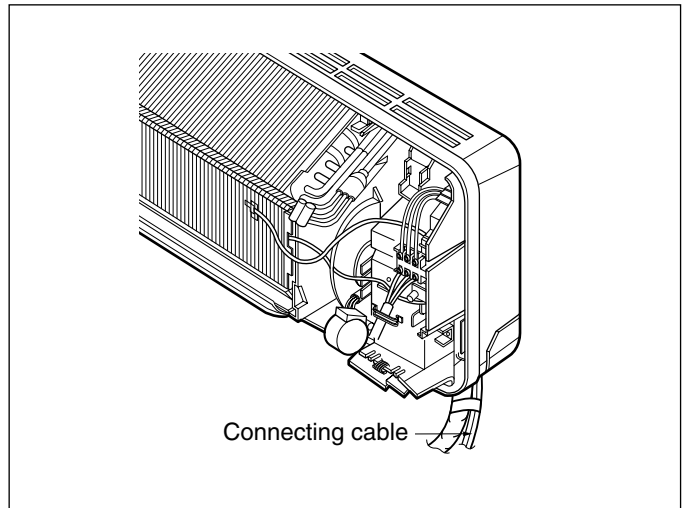

WARNING

- Be sure to refer to the wiring diagram label inside the cover control and carry out the correct field wiring.
Wrong wiring can cause the unit to misoperate to result in a fire hazard.
- Check local electrical codes and any specified wiring instructions or limitations.

2. Attach the Grille onto the cabinet.

- Grasp lower the left and right side of the Grille and engage four tabs on the top inside edge of the chassis.
- Press the Grille toward the chassis until it will be back into place.

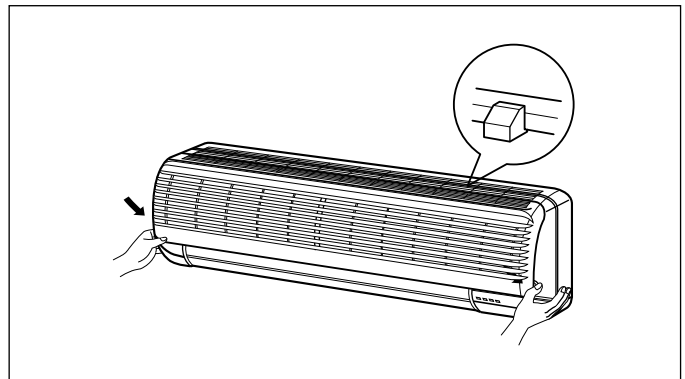

3) Forming the pipings

1. Wrap the connecting portion of indoor unit with the Insulation material and secure it with two Plastic Bands.(for the right pipings)

- If you want to connect an additional drain hose, the end of the drain-outlet should keep distance from the ground.(Do not dip it into water, and fix it on the wall to avoid swinging in the wind.)

In case of the Outdoor unit being installed below position of the Indoor unit.

2. Tape the Pipings, drain hose and Connecting Cable from down to up.

3. Form the pipings gathered by taping along the exterior wall and fix it onto the wall by saddle or equivalent.

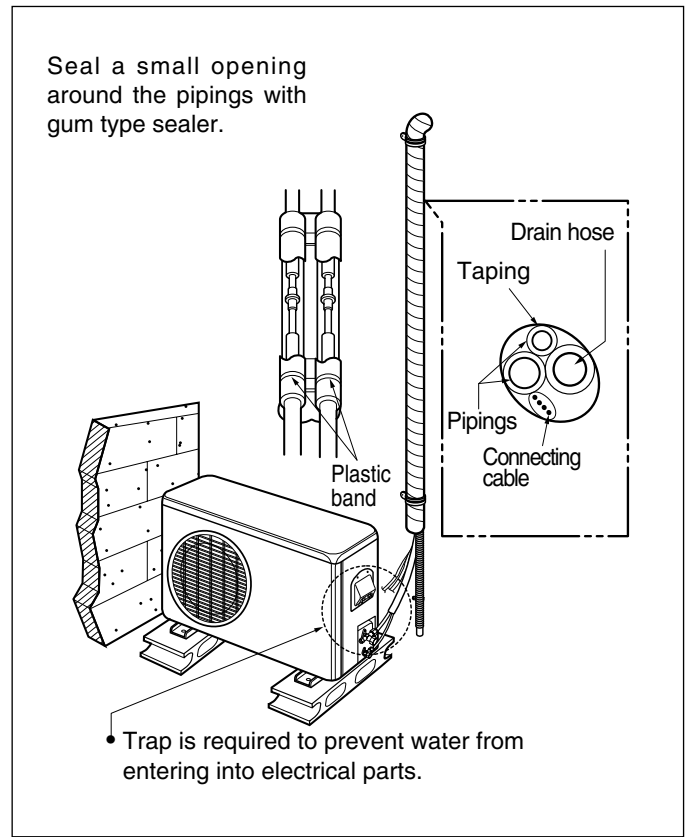

In case of the Outdoor unit being installed above position of the Indoor unit.

2. Tape the Pipings and Connecting cable from down to up.

3. Form the pipings gathered by taping along the exterior wall, make the Trap to be required to prevent water from entering into the room.

4. Fix the pipings onto the wall by saddle or equivalent.

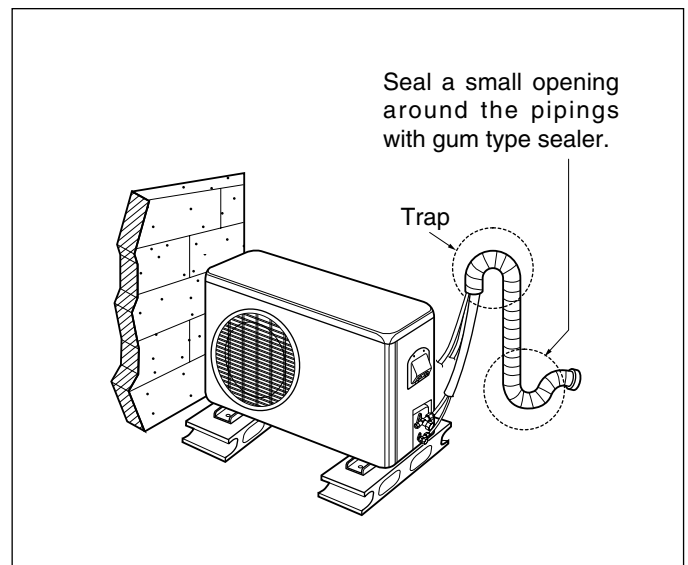

(6) Air Purging

Air and moisture remaining in the refrigerant system have undesirable effects as indicated below.

- Pressure in the system rises.
- Operating current rises.
- Cooling(or heating) efficiency drops.
- Moisture in the refrigerant circuit may freeze and block capillary tubing.
- Water will lead to corrosion and refrigeration system failure.

The indoor unit and tubing between the indoor and outdoor unit must be leak tested and evacuated to remove any noncondensables and moisture from the system.

1) Air Purging with a Vacuum Pump

■ Preparation

Check that each tube(both liquid and gas side tubes) between the indoor and outdoor units has been properly connected and all wiring for the test run has been completed. Remove the valve caps from both the gas and the liquid side service valves on the outdoor unit. Note that both liquid and gas side service valves on the outdoor unit are kept closed at this stage.

■ Leak test

1. Connect the manifold valve(with pressure gauges) and dry nitrogen gas cylinder to this service port with charge hoses.

CAUTION: Be sure to use a manifold valve for air purging. If it is not available, use a stop valve for this purpose. The "Hi" knob of the manifold valve must always be kept close.

2. Pressurize the system to no more than 150 P.S.I.G with dry nitrogen gas and close the cylinder valve when the gauge reading reached 150 P.S.I.G. Next, test for leaks with liquid soap.

CAUTION: To avoid nitrogen entering the refrigerant system in a liquid state, the top of the cylinder must be higher than its bottom when you pressurize the system. Usually, the cylinder is used in a vertical standing position.

3. Do a leak test of all joints of the tubing(both indoor and outdoor) and both gas and liquid side service valves. Bubbles indicate a leak. Be sure to wipe off the soap with a clean cloth.
4. After the system is found to be free of leaks, relieve the nitrogen pressure by loosening the charge hose connector at the nitrogen cylinder. When the system pressure is reduced to normal, disconnect the hose from the cylinder.

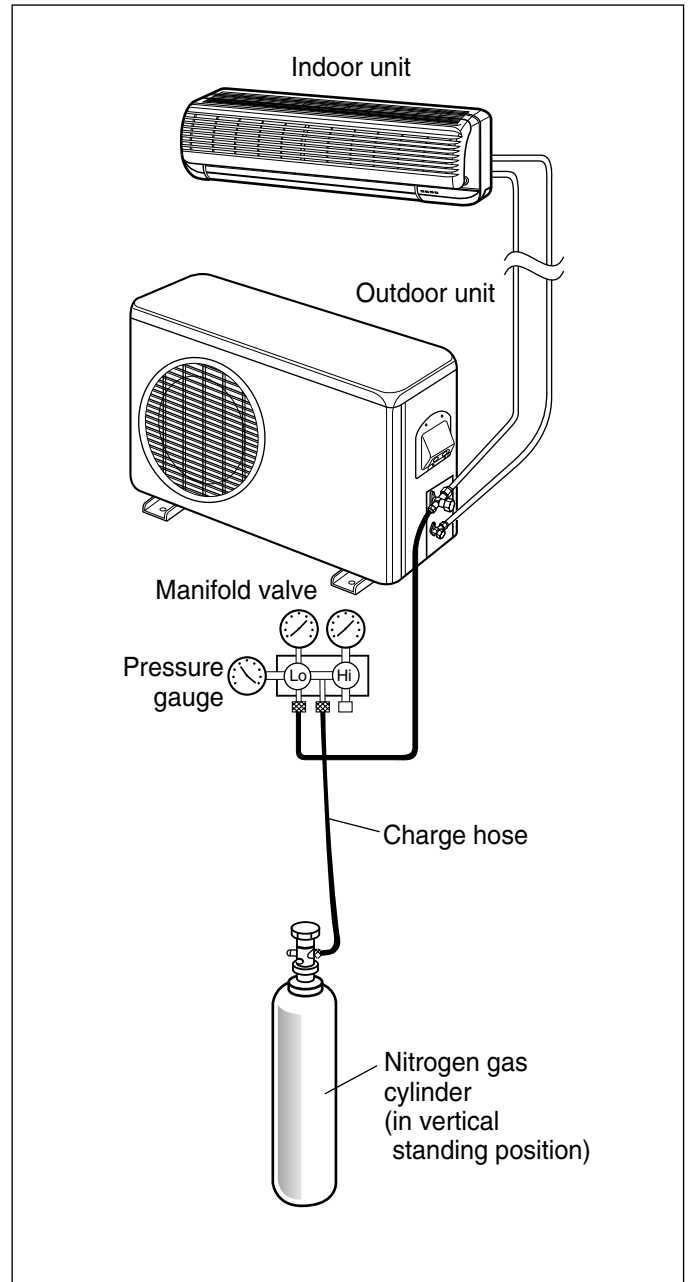

■ Evacuation

1. Connect the charge hose end described in the preceding steps to the vacuum pump to evacuate the tubing and indoor unit.

Confirm the "Lo" knob of the manifold valve is open. Then, run the vacuum pump.

The operation time for evacuation varied with the tubing length and capacity of the pump. The following table shows the amount of time for evacuation.

Allow the pump to operate until the system has been evacuated down to 300 microns. Allow the pump to continue running for an additional 15 minutes. Turn off the pump and leave the connections secured to the two service valves. After 5 minutes, if the system fails to hold 500 microns or less, check all connections for tight fit and repeat the evacuation procedure.

2. When the desired vacuum is reached, close the "Lo" knob of the manifold valve and stop the vacuum pump.

■ Finishing the job

1. With a service valve wrench, turn the valve stem of liquid side valve counter-clockwise to fully open the valve.
2. Turn the valve stem of gas side valve counter-clockwise to fully open the valve.
3. Loosen the charge hose connected to the gas side service port slightly to release the pressure, then remove the hose.
4. Replace the flare nut and its bonnet on the gas side service port and fasten the flare nut securely with an adjustable wrench. This process is very important to prevent gas leakage from the system.
5. Replace the valve caps at both gas and liquid side service valves and fasten them securely tight.

This complete air purging with a vacuum pump. The air conditioner is now ready to test run.

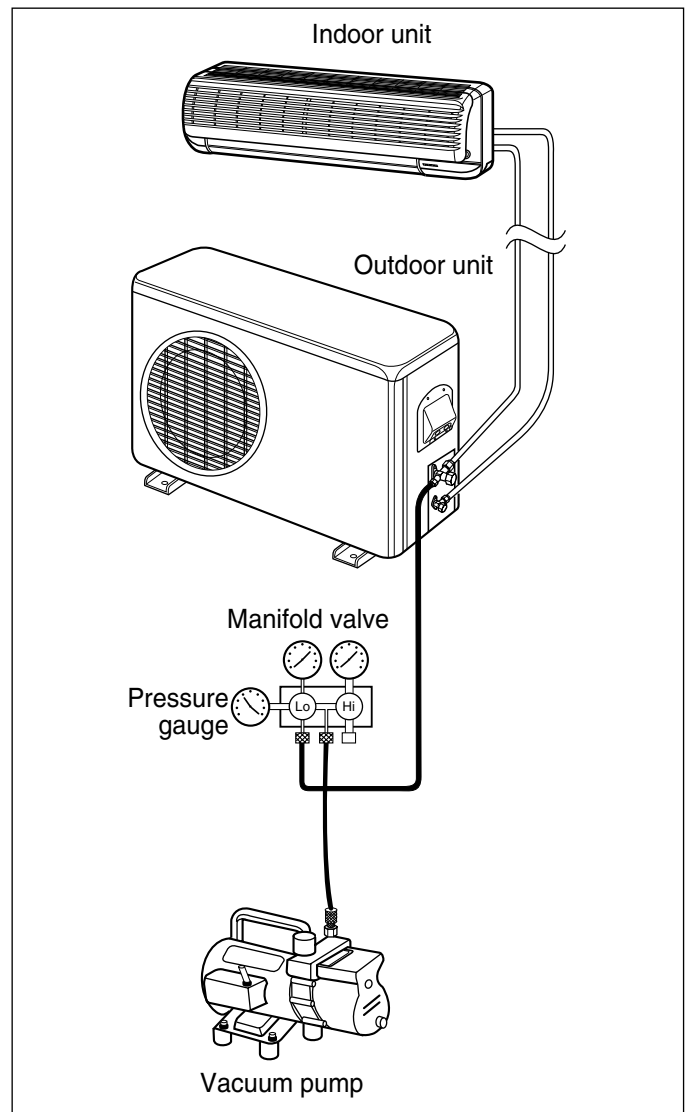

(7) Test running

- (1) Check that all tubing and wiring have been properly connected.
- (2) Check that the gas and liquid side service valves are fully open.

Prepare to Remote Control

- Insert two batteries provided.
Remove the battery cover from the remote controller.
 - Slide the cover according to the arrow direction. Insert the two batteries. (Two "R03" or "AAA" dry-cell batteries or equivalent.)
 - Be sure that the (+) and (-) directions are correct.
 - Be sure that both batteries are new. Re-attach the cover.
 - Slide it back into position.
- (3) Turn on the power and run the unit.

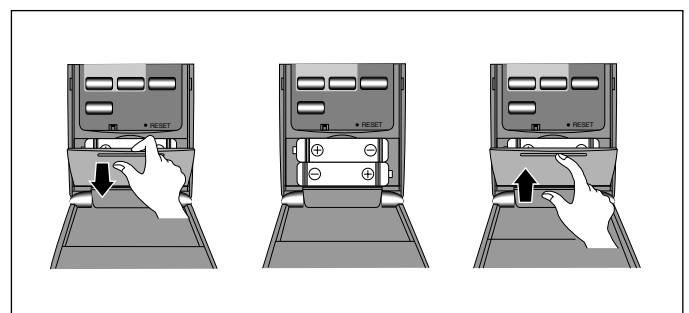

Settlement of Outdoor Unit

- Anchor the outdoor unit with a bolt and nut ($\phi 10\text{mm}$) tightly and horizontally on a concrete or rigid mount.
- When installing on the wall, roof or rooftop, anchor the mounting base securely with a nail or wire assuming the influence of wind and earthquake.
- In the case when the vibration of the unit is conveyed to the house, settle the unit with an anti-vibration rubber.

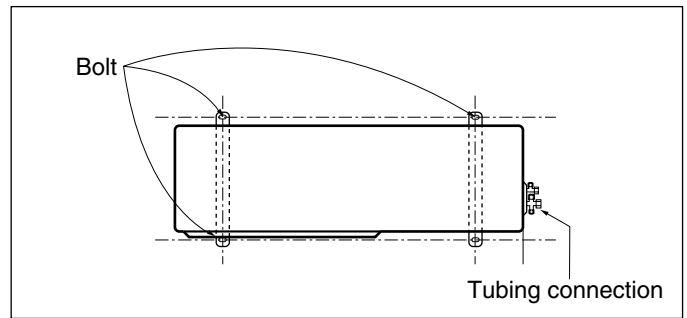

Evaluation of the performance

Operate unit for 15~20 minutes, then check the system refrigerant charge:

- (1) Measure the pressure of the gas side service valve.
- (2) Measure the outside ambient air temperature.
- (3) For reference; the gas side pressure of optimum condition is as below;

Outside ambient TEMP.	The Pressure of the gas side service valve
35°C(95°F)	4~5kg/cm ² (56.8~71.0 P.S.I.G)

NOTE: If the actual pressure are higher than shown, the system is most likely over-charged, and charge should be removed. If the actual pressure are lower than shown, the system is most likely undercharged, and charge should be added.

The air conditioner is now ready for actual operation.

Temperature, Pressure, Ampere Chart

NOTE

- Discharge Air Temperature, °F
- Low pressure, P.S.I.G
- Rated Load Current, A

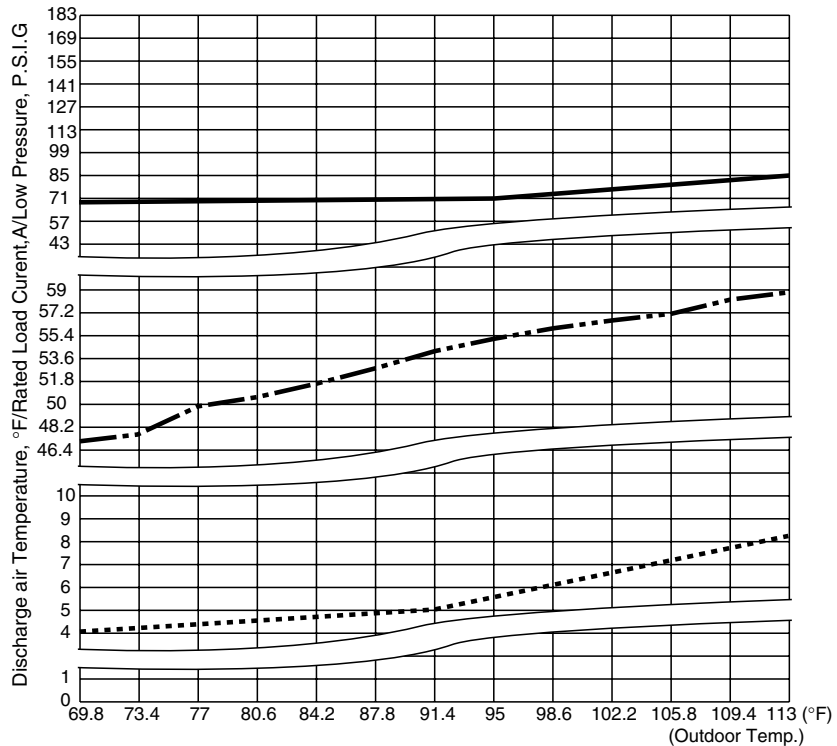

Operation

Name and Function-Remote Controller

1) Cooling Model

Remote Controller

Signal transmitter

Transmits the signals to the room air conditioner.

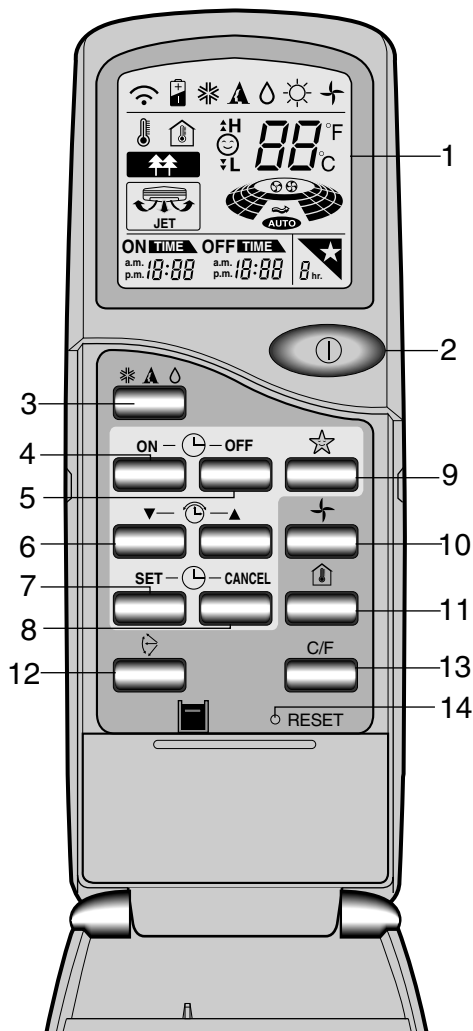

1 Operation display

Displays the operation conditions.

2 Start/Stop Button

- Operation starts when this button is pressed, and stops when the button is pressed again.
- The fan blows at low speed when start button is pressed initially, after a while the fan speed will be reached at the desired speed.

3 Operation Mode Selection Button

Used to select the operation mode.

- Cooling Operation Mode.
- Auto Operation Mode.
- Soft Dry Operation Mode.

4 ON Timer Button

Used to set the time of starting operation.

5 OFF Timer Button

Used to set the time of stopping operation.

6 Time Setting Button

Used to adjust the time.

7 Timer Set Button

Used to set the timer when the desired time is obtained.

8 Timer Cancel Button

Used to cancel the timer operation.

9 Sleep Mode Auto Button

Used to set Sleep Mode Auto Operation.

10 Air Circulation Button

Used to circulate room air without cooling.

11 Room Temperature Checking Button

Used to check the room temperature.

12 Airflow Direction Control Button

Used to set the desired vertical airflow direction.

13 °C to °F Switching Button

Used to switch temperature reading from Centigrade to Fahrenheit.

14 Reset Button

2) Heating Model

Remote Controller

Signal transmitter

Transmits the signals to the room air conditioner.

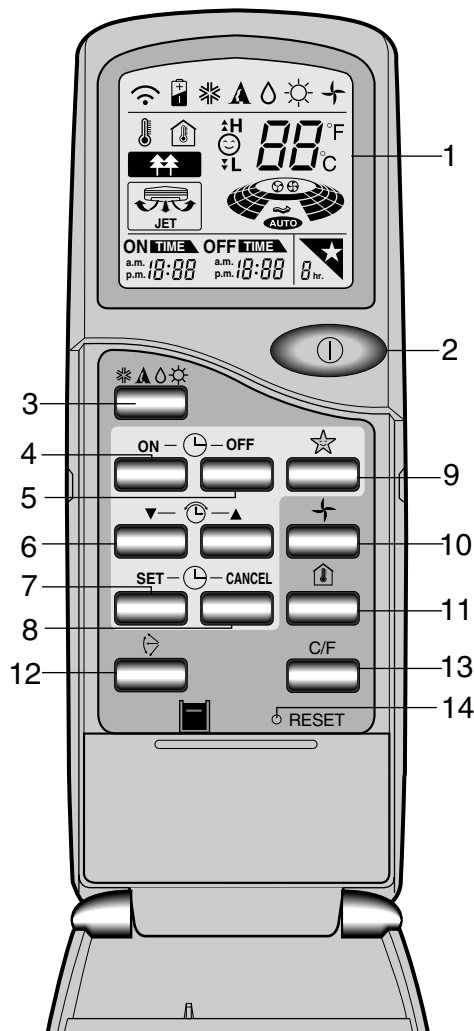

1 Operation display

Displays the operation conditions.

2 Start/Stop Button

- Operation starts when this button is pressed, and stops when the button is pressed again.
- The fan blows at low speed when start button is pressed initially, after a while the fan speed will be reached at the desired speed.

3 Operation Mode Selection Button

Used to select the operation mode.

- Cooling Operation Mode.
- Auto Operation Mode.
- Soft Dry Operation Mode.
- Heating Operation Mode(Heat Pump Only).

4 ON Timer Button

Used to set the time of starting operation.

5 OFF Timer Button

Used to set the time of stopping operation.

6 Time Setting Button

Used to adjust the time.

7 Timer Set Button

Used to set the timer when the desired time is obtained.

8 Timer Cancel Button

Used to cancel the timer operation.

9 Sleep Mode Auto Button

Used to set Sleep Mode Auto Operation.

10 Air Circulation Button

Used to circulate room air without cooling.

11 Room Temperature Checking Button

Used to check the room temperature.

12 Airflow Direction Control Button

Used to set the desired vertical airflow direction.

13 °C to °F Switching Button

Used to switch temperature reading from Centigrade to Fahrenheit.

14 Reset Button

Disassembly of the parts (Indoor unit)

(1) 9k, 12k Models(Cooling Only, Cooling & Heating)



WARNING

Hazardous voltage can cause ELECTRIC SHOCK or DEATH. Turn off circuit breaker before you start checking or servicing.

1. To remove the Grille from the Chassis

- Set the up-and-down air discharge louver to open position (horizontally) by finger pressure.
- Remove the securing screws.
- To remove the Grille, pull the lower left and right side of the grille toward you (slightly tilted) and lift it straight upward.

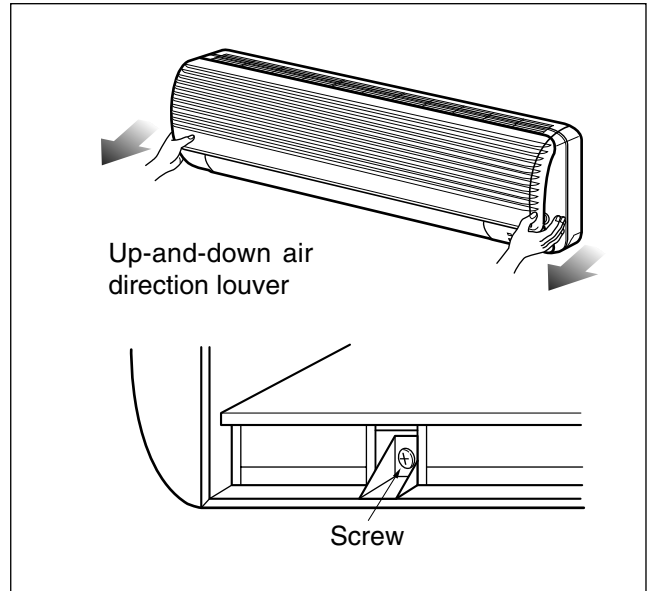

2. To remove the Control Box

- Remove the thermistors. One from thermistor holder on evaporator, the other from pipe holder.
- Remove step motor connector, motor connector from main P. C. B.
- If necessary, disconnect DC power supply cord from pillar terminal, and remove the clip screw. (Be careful not to lose the clip when reassembling)

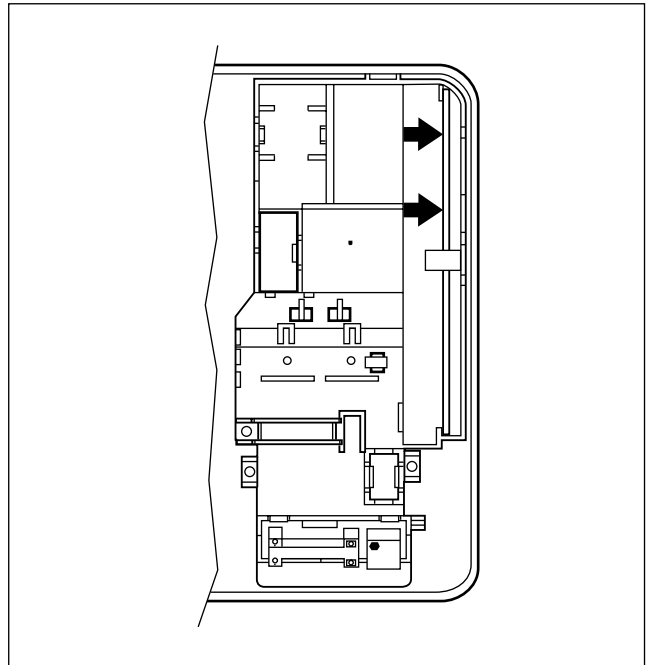

- Remove 2 securing screws.
- Unhook the three hooks.
- Pull the control box out from the chassis carefully.

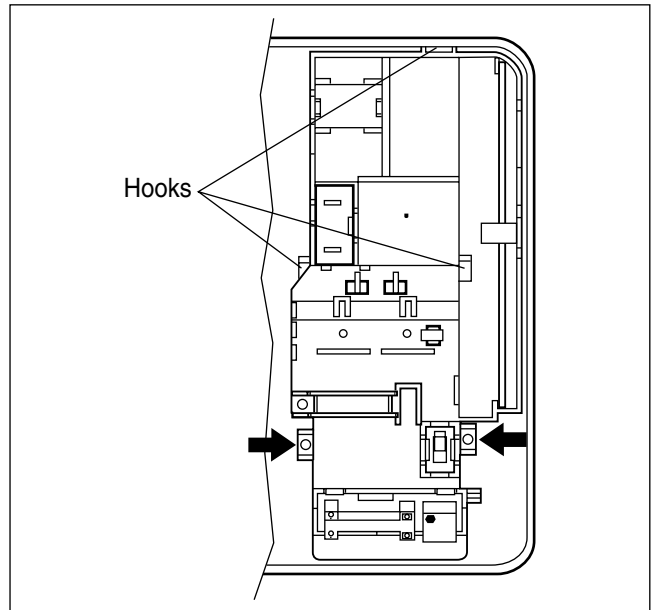

3. To remove the Discharge Grille.

- Remove the securing screw.
- Pull the discharge grille out from the chassis carefully.

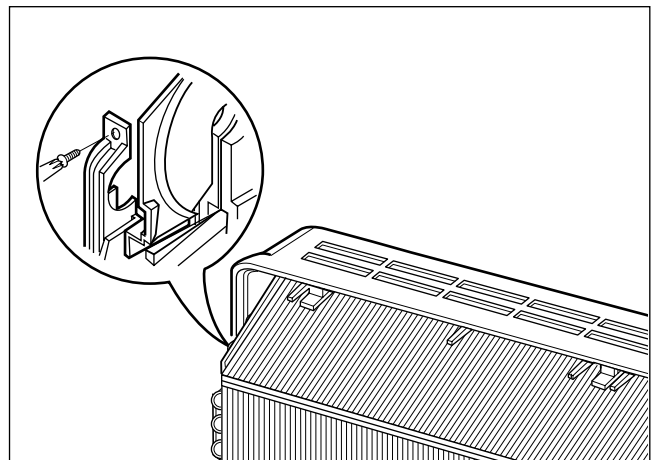

4. To remove the Evaporator.

- Remove two screws on the left side of the evaporator.

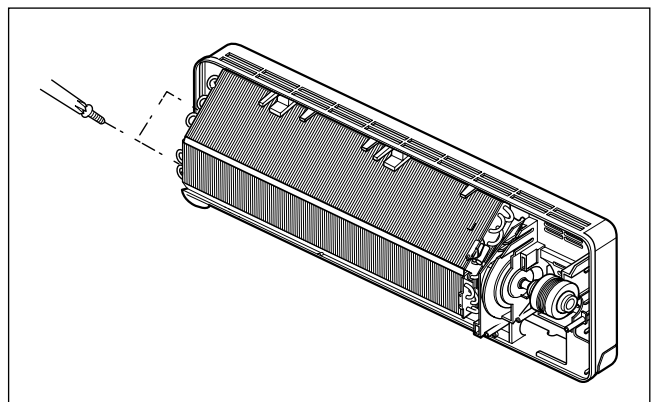

- Push right carefully in order to unhook the tabs on the right side of the chassis and pull the evaporator toward you.

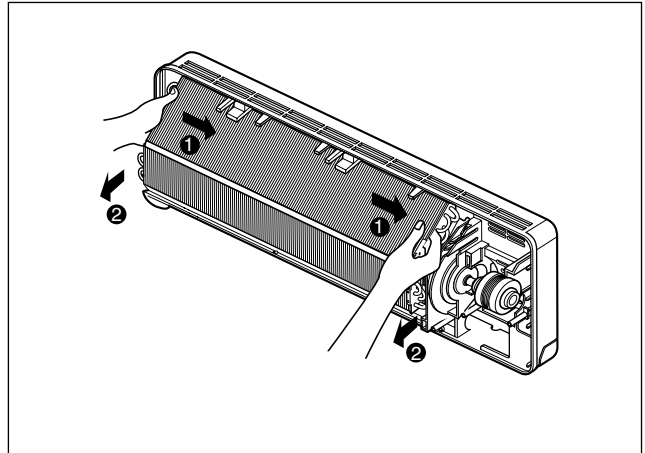

5. To remove the Cross-Flow Fan

- Loosen the screw securing the cross-flow fan to the fan motor (do not remove).

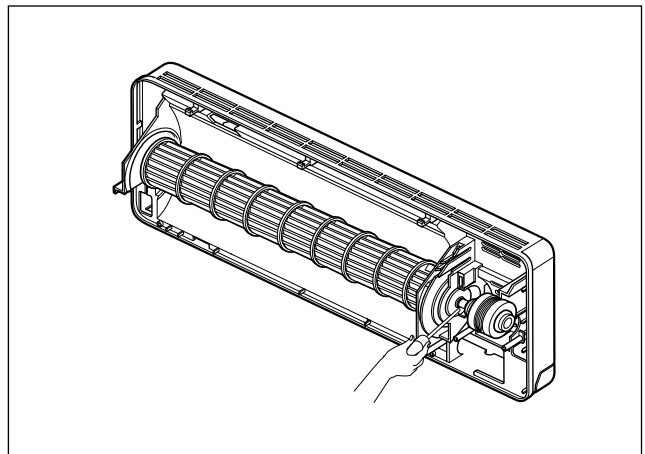

- Pull the left end of the cross-flow fan with the self-aligning bearing out the groove.
- Remove the cross-flow fan by sliding it out from the shaft of fan motor.

6. To remove the Fan Motor

- Pick it up from the groove. (Do not remove a black rubber as a spacer).

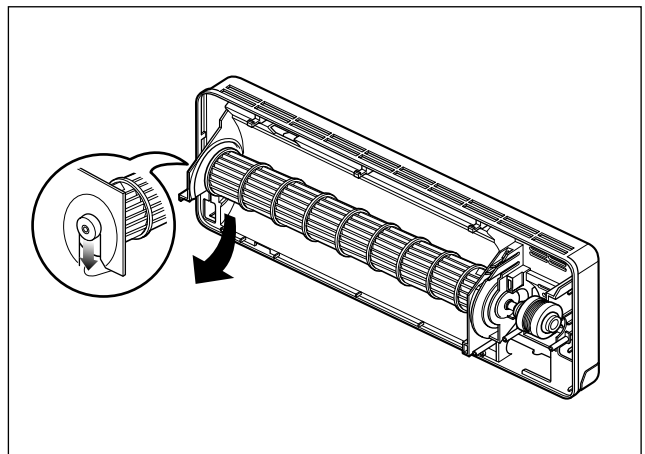

(2) 18k, 24k Models(Cooling Only, Cooling & Heating)

WARNING

Hazardous voltage can cause ELECTRIC SHOCK or DEATH. Turn off circuit breaker before you start checking or servicing.

1. To remove the Grille from the Chassis

- Set the up-and-down air discharge louver to open position (horizontally) by finger pressure.
- Remove the securing screws at the bottom of grille.
- To remove the Grille, pull the lower left and right side of the grille toward you (Slightly tilted) and lift it straight upward.

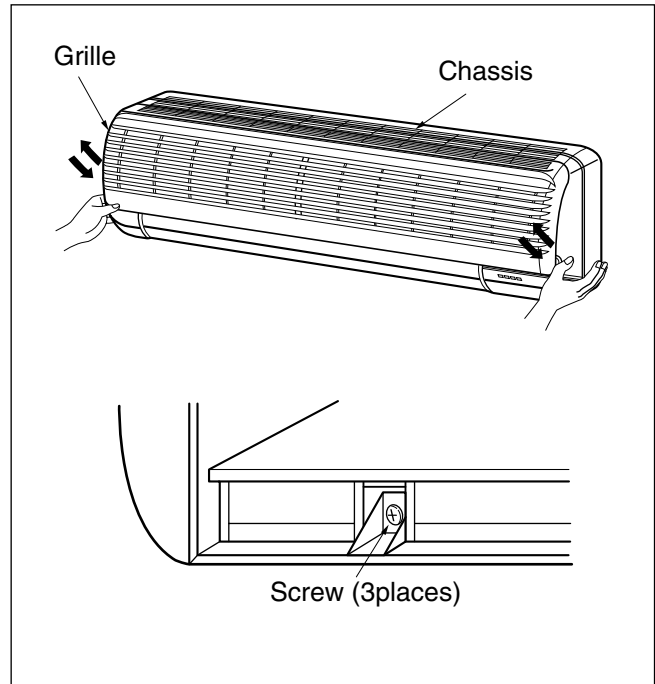

2. To remove the Control Box

- Remove the thermistors. One from thermistor holder on evaporator, the other from pipe holder.
- Remove step motor connector from main P. C. B.
- If necessary, disconnect DC power supply cord from pillar terminal, and remove the clip screw. (Be careful not to lose the clip when reassembling)

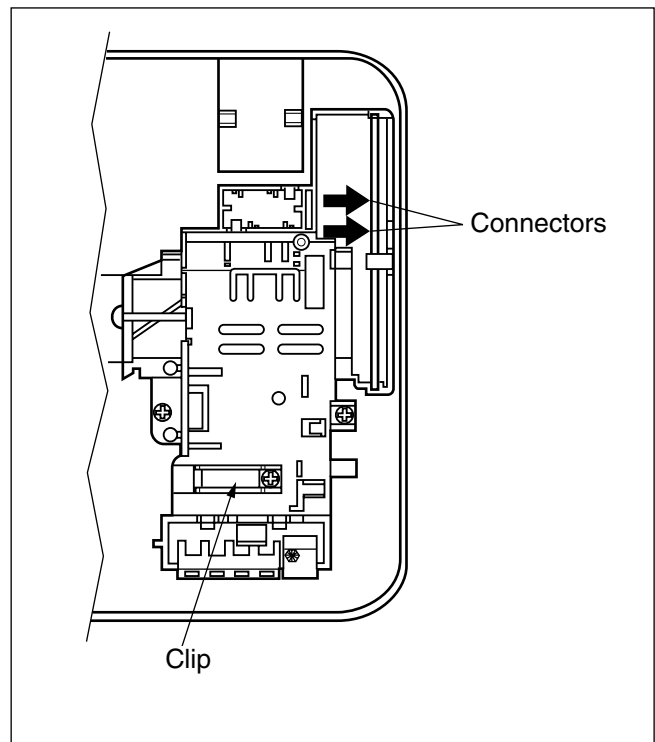
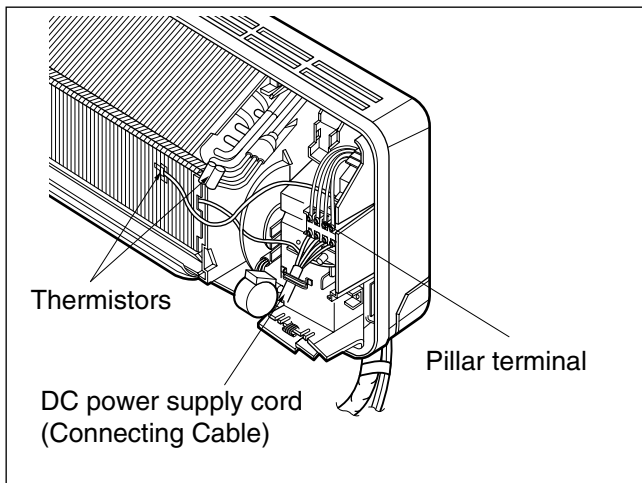

- Remove three screws fixing control box and motor.
- Remove control box assembly holding two hooks fixing upper sides of motor.

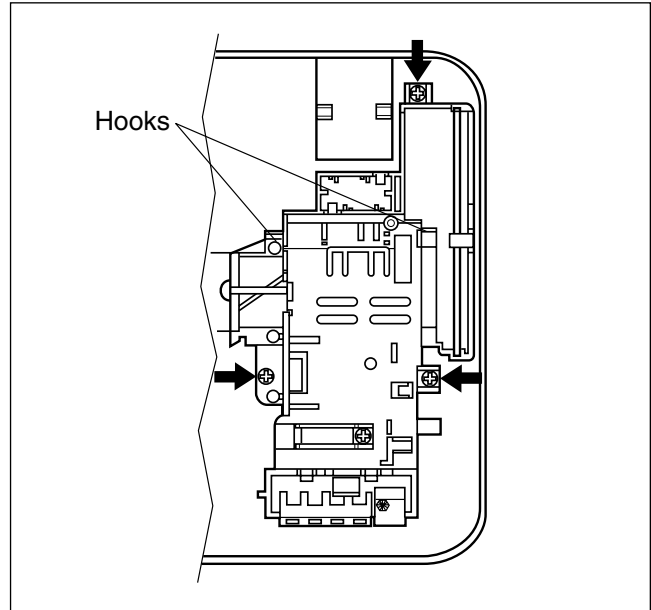

3. To remove the Discharge Grille.

- Remove a screw on the left side of chassis.
- Pull the right side of the discharge grille out from the chassis first and left side carefully.

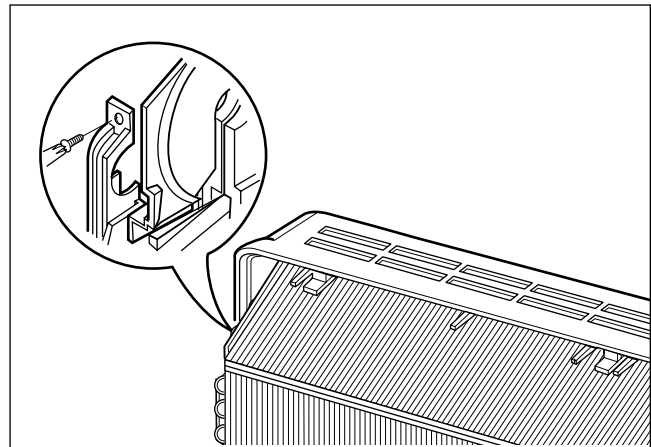

4. To remove the Evaporator.

- Unhook the tab on the left inside edge of the chassis by pressing it outwards.

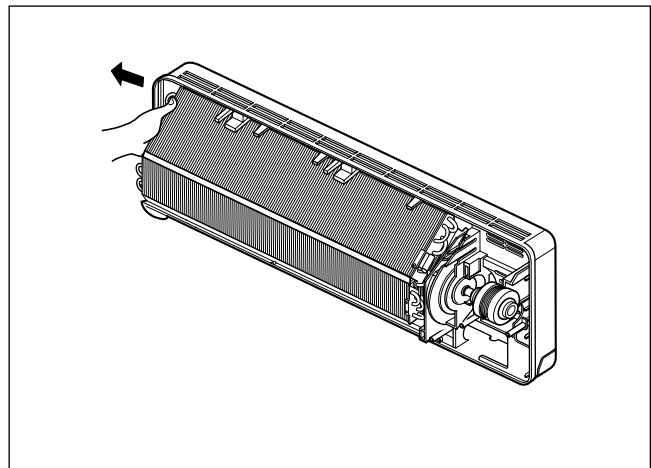

- Slightly pull the evaporator until left tab on end-plate is clear of the chassis.
- Lift the left side of evaporator slightly from the chassis carefully.

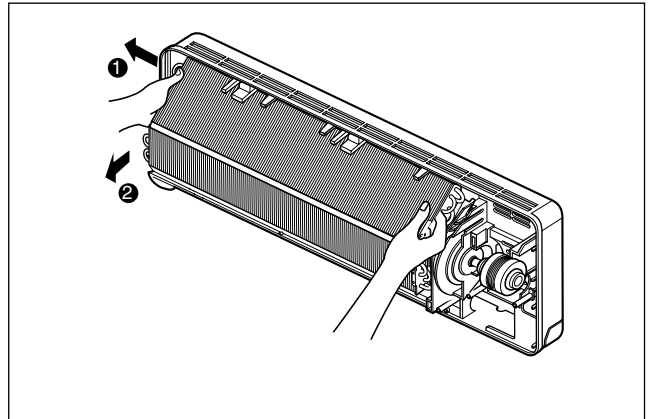

- Push right carefully in order to unhook the tabs on the right inside of the chassis and pull the evaporator toward you.

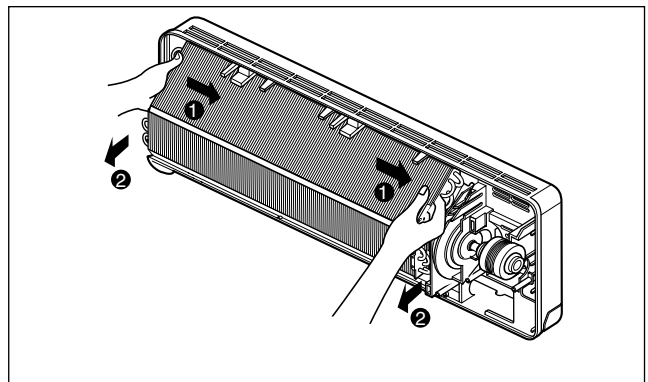

5. To remove the Cross-Flow Fan.

- Loosen the screw securing the cross-flow fan to the fan motor shaft(do not remove).

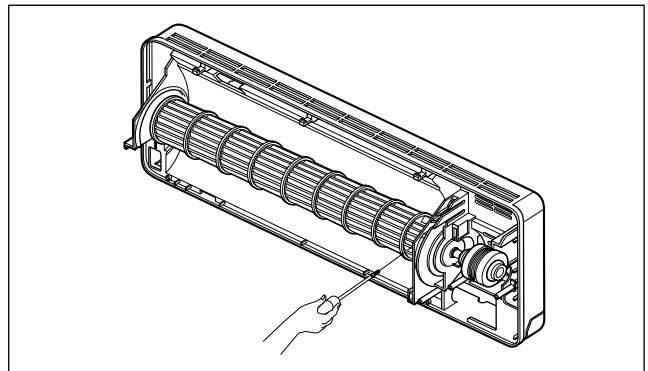

- Pull the left end of the cross-flow fan with the selfaligning bearing out the groove.
- Remove the cross-flow fan by sliding it out from the shaft of fan motor.

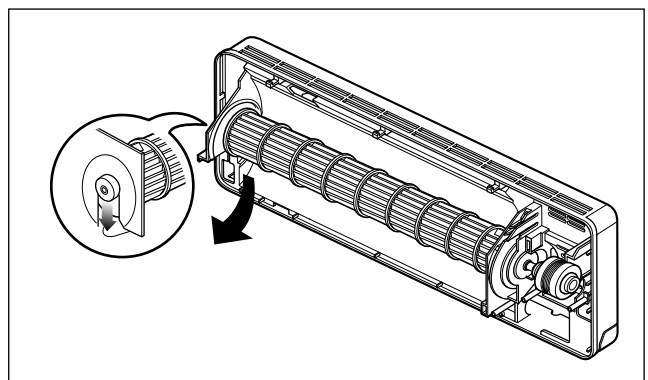

6. To remove the Fan Motor.

- Pick it up from the groove. (Do not remove a black rubber as a spacer).

Cycle Troubleshooting Guide

1. Trouble analysis

1. Check temperature difference between intake and discharge air and operating current.

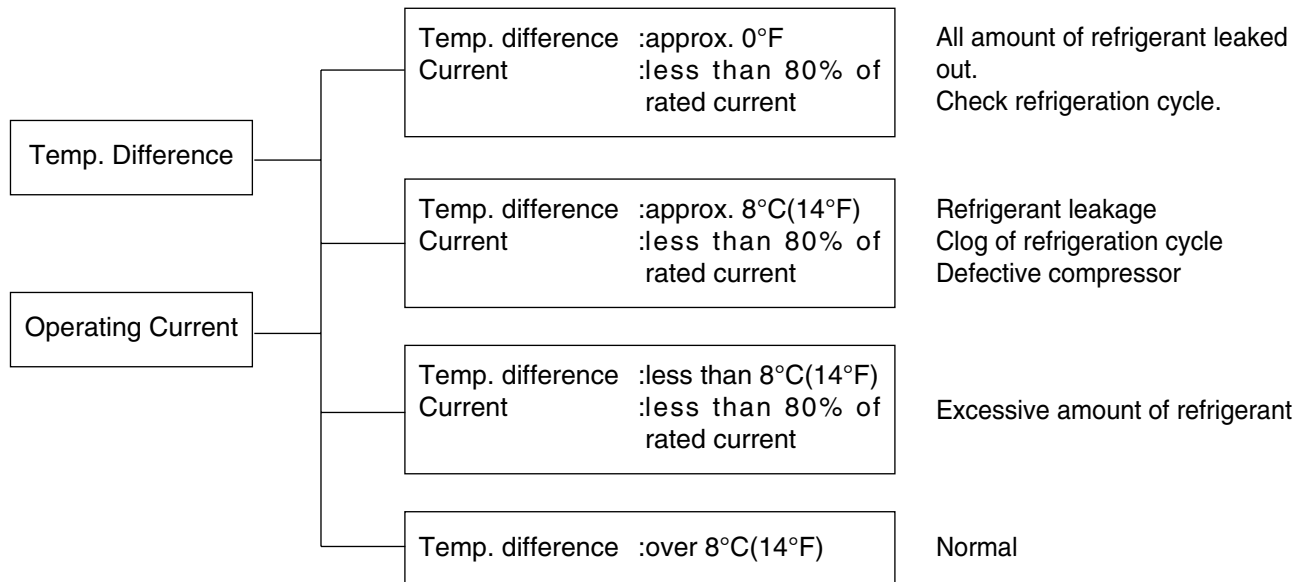

Notice:

Temperature difference between intake and discharge air depends on room air humidity. When the room air humidity is relatively higher, temperature difference is smaller. When the room air humidity is relatively lower temperature difference is larger.

2. Check temperature and pressure of refrigeration cycle.

Suction pressure (Compared with the normal value)	Temperature (Compared with the normal value)	Cause of Trouble	Description
Higher	High	Defective compressor Defective 4-way reversing valve	Current is low.
	Normal	Excessive amount of refrigerant	High pressure does not quickly rise at the beginning of operation.
Lower	Higher	Insufficient amount of refrigerant(Leakage) Clogging	Current is low. Current is low.

Notice:

1. The suction pressure is usually 56.8~71.0 PSIG at normal condition.
2. The temperature can be measured by attaching the thermometer to the low pressure tubing and wrap it with putty.

2. Product does not operate at all.

(* Refer to Electronic Control Device drawing and Schematic diagram.)

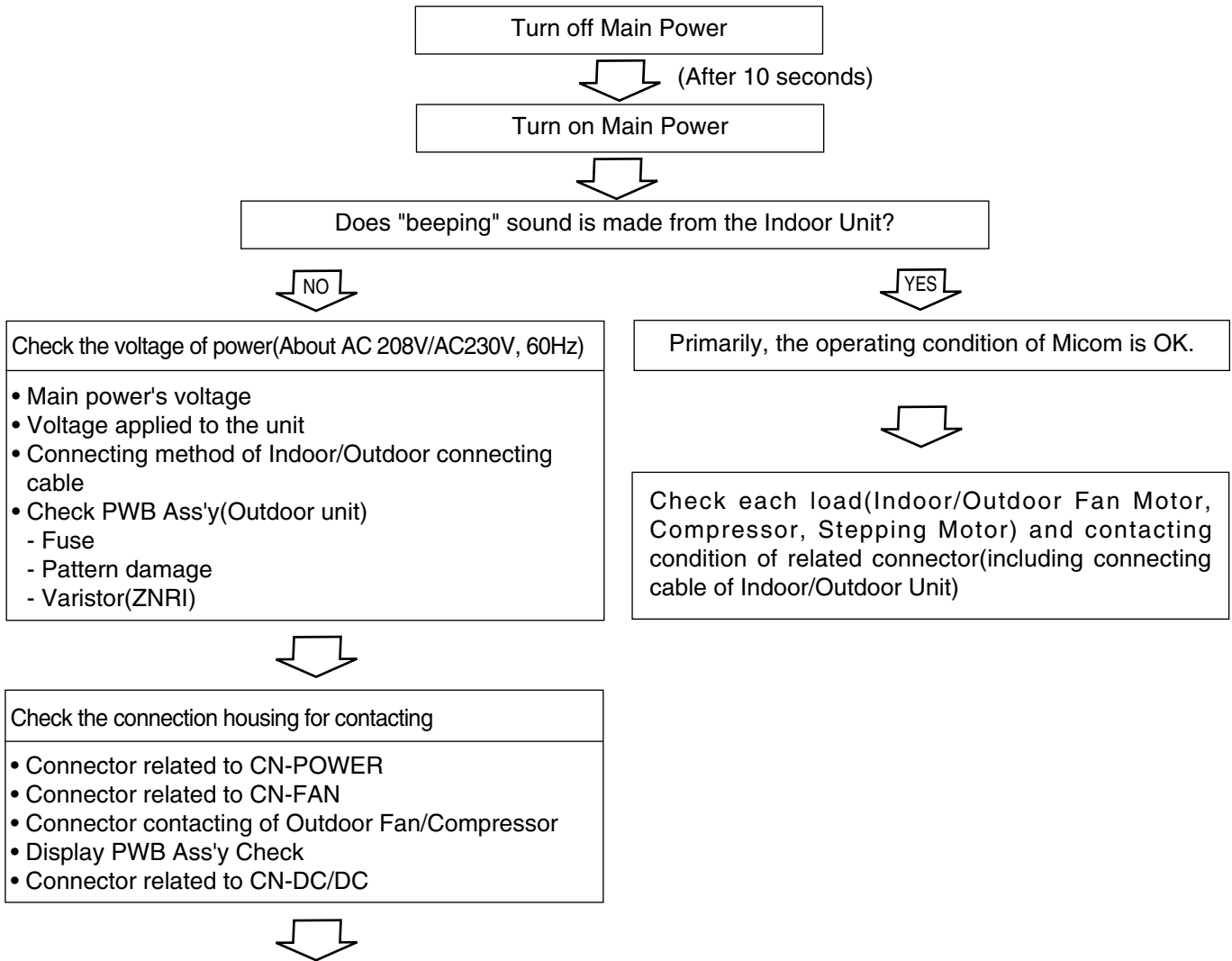

PCB Board Operation Check		
Items	Content	Remedy
<ul style="list-style-type: none"> • Power Transformer (Outdoor unit) - Input Voltage - Output Voltage <li style="text-align: center;">↓ • IC2(7812) Output (Indoor/Outdoor unit) <li style="text-align: center;">↓ • IC3(7805) Output (Indoor/Outdoor unit) <li style="text-align: center;">↓ • IC4(KIA7036, Reset IC) X01(4MHz) (Indoor/Outdoor unit) 	<ul style="list-style-type: none"> - About AC208V/230V±10% - Check the power voltage - About AC17±3V • DC +12V • DC +5V • Voltage of Outdoor unit Micom No. 8, Voltage of Indoor unit Micom No. 43 and soldering condition 	<ul style="list-style-type: none"> • Replace Trans • Replace IC2 • Replace IC3 • Replace faulty parts

3. The product is not operate with the remote controller.

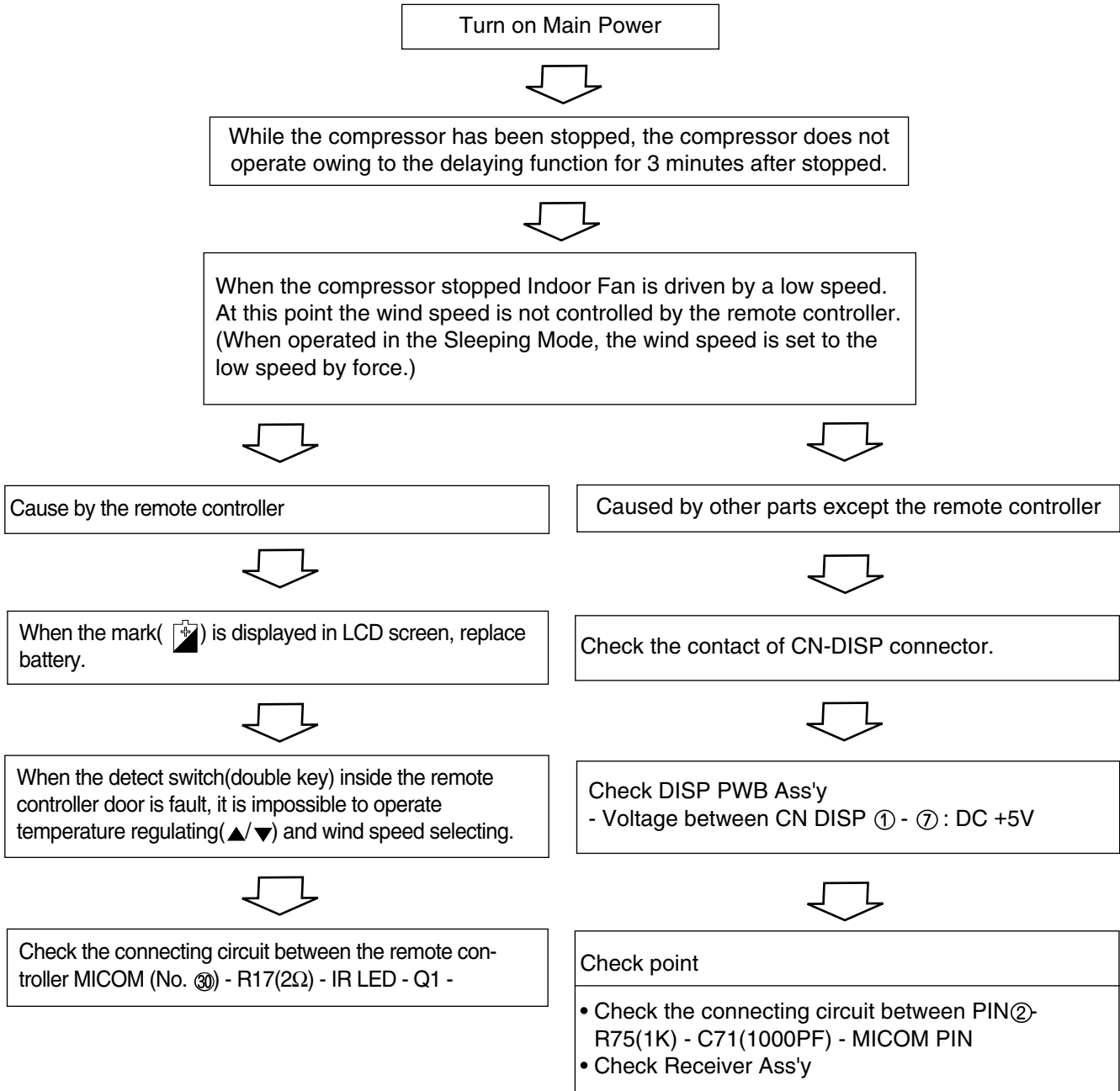

4. Compressor/Outdoor Fan are unable to drive.

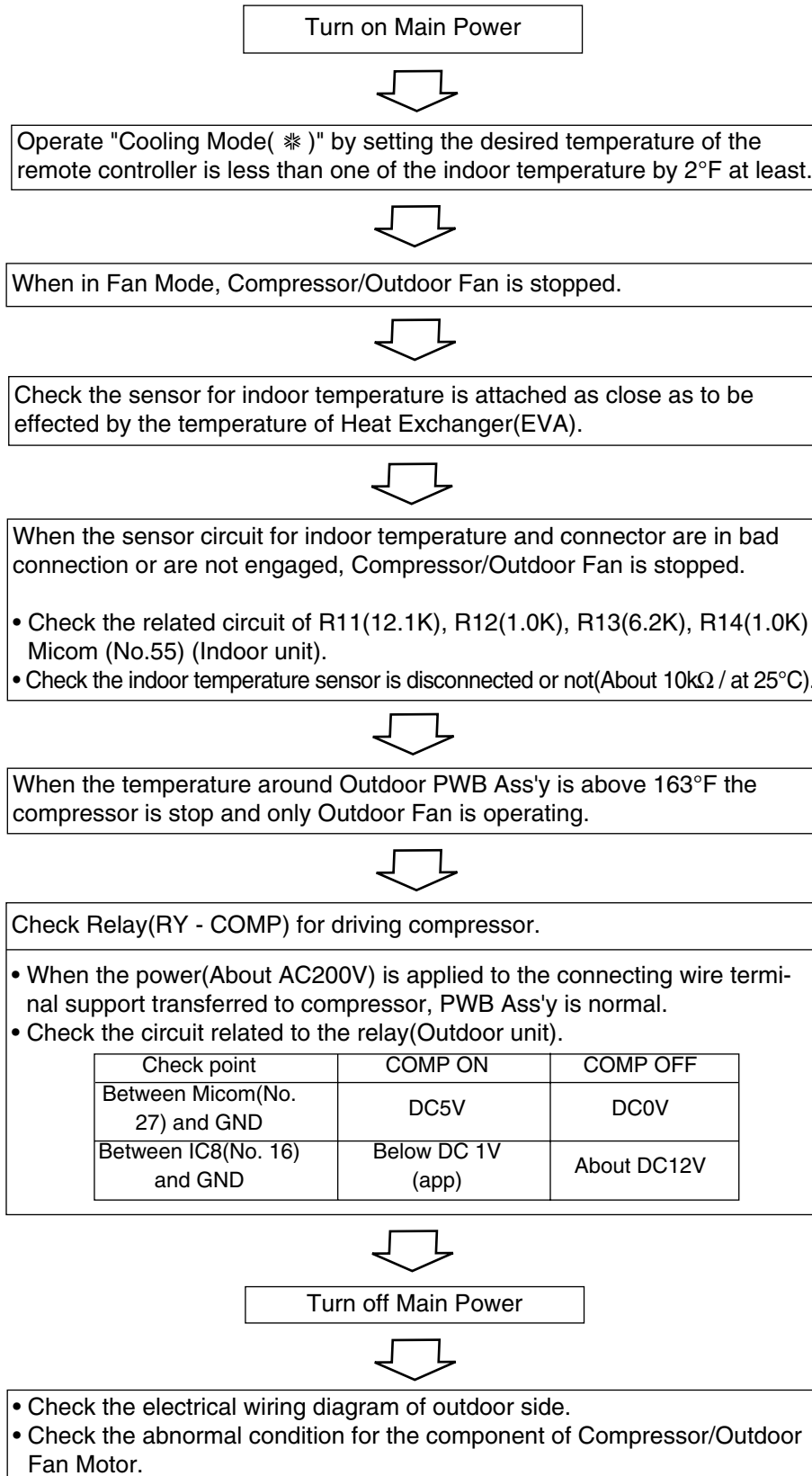

5. When Indoor Fan does not operate.

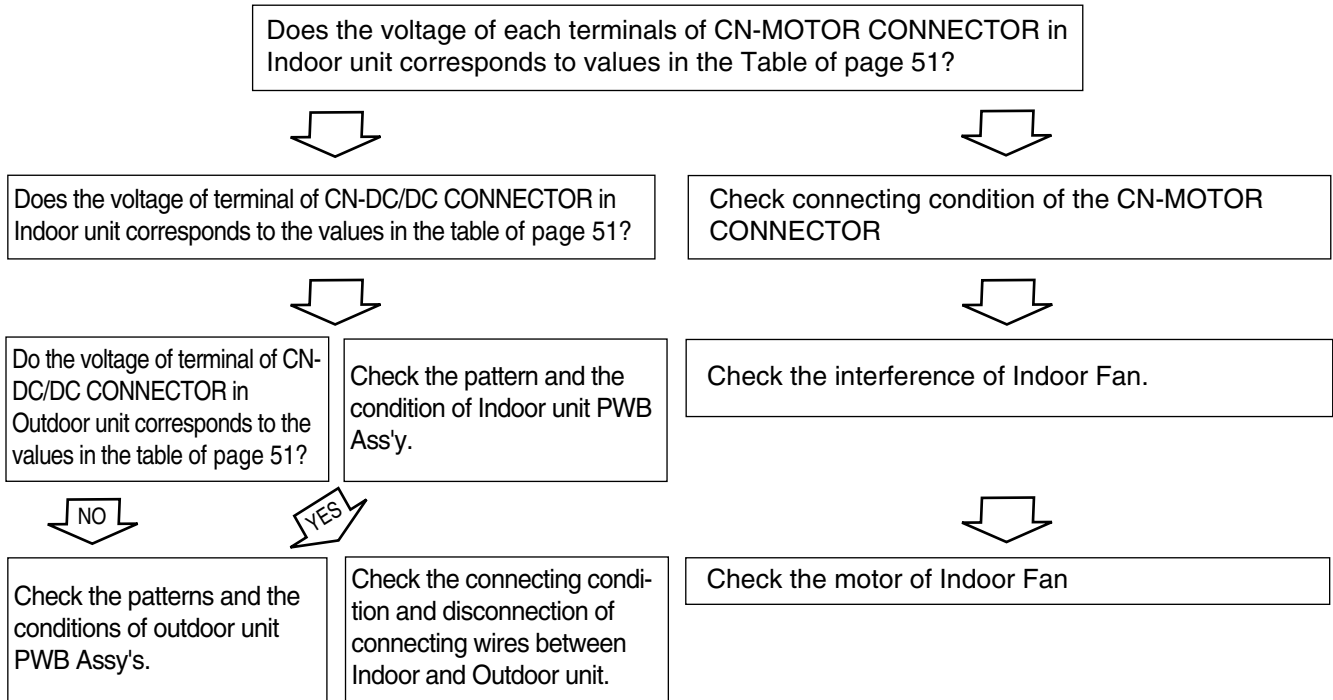

- ※ Indoor Fan may be stopped in the Soft Dry Mode(change to the Cooling Operation Mode).
- ※ Indoor Fan is to be stopped when Indoor pipe(coil) temperature is lower than 79°F.
(At that times, Defrost indicator is turned on)

6. When Vertical Louver does not operate.

- Confirm that the Vertical Louver is normally geared with the shaft of Stepping Motor.
- If the regular torque is detected when rotating the Vertical Louver with hands ⇒ Normal



- Check the connecting condition of CN-UP/DOWN Connector
- Check the soldering condition(on PWB) of CN-UP/DOWN Connector



Check the operating circuit of the Vertical Louver

- Confirm that there is DC +12V between pin②(RE D) of CN-UP/DOWN and GND.
- Confirm that there is a soldering short at following terminals.
 - Between ②⑥, ②⑦, ②⑧ and ②⑨ of MICOM
 - Between ③, ④, ⑤ and ⑥ of IC7
 - Between ⑪, ⑫, ⑬ and ⑭ of IC7
 - Between ①, ②, ③, ④ and ⑤ of CN-UP/DOWN



If there are no problems after above checks

- Confirm the assembly conditions that are catching and interfering parts in the rotation radial of the Vertical Louver

7. When a communication error occurs.

- The operation indicator of Indoor unit blinks five times.
- The red indicator of Outdoor unit blinks five times.



Check the connecting wires between Indoor and Outdoor unit for the connecting error and the contacting condition.



Check the installation condition of outdoor unit.



Check for the communication error and the operating condition of product after also operating with the remote controller, then taking above 2 minutes.



Apply the power again after about 10 seconds by the power of Outdoor unit is off.



Check for the communication error and the operating condition of product after also operating with the remote controller, then taking above 2 minutes.



Check the PWB assembly of Indoor and Outdoor unit.

Caution: If the connecting wires of Indoor and Outdoor unit are not connected within 2 minutes after the power of Outdoor unit is applied, a communication error will occur. Therefore, the power should be applied after connecting them.

8. The phenomena in case of connecting error

INDOOR UNIT

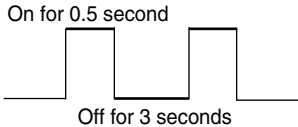
Connector Type	Condition	Phenomena
CN-DC/DC  ① Blue ② Black ③ Brown ④ Red	Open and connecting error	<ul style="list-style-type: none"> The same as the phenomenon of Outdoor Unit.
CN-MOTOR	Open	<ul style="list-style-type: none"> The indoor fan does not operate. The operation indicator of Indoor unit blinks 8 times.
CN-UP/DOWN	Open	<ul style="list-style-type: none"> The up/down vane does not operate.
	Short between terminals	<ul style="list-style-type: none"> The up/down vane does not smoothly operate.
CN-DISP	Open	<ul style="list-style-type: none"> It does not operate with a remote controller.
CN-TH	Open	<ul style="list-style-type: none"> The operation indicator blinks once.  <ul style="list-style-type: none"> The compressor and the outdoor fan stop. The indoor fan speed is low.
	Short between terminals (③ and ④) of ROOM-TH.	<ul style="list-style-type: none"> The operation indicator blinks once (on for 0.5 second, off for 3 seconds). The compressor operates continuously regardless of the setting temperature and the variation of room temperature.
	Short between terminals (① and ②) of PIPE-TH.	<ul style="list-style-type: none"> The operation indicator blinks once (on for 0.5 second, off for 3 seconds) Continuous operation

OUTDOOR UNIT

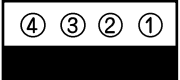
Connector Type	Condition	Phenomena
CN-POWER	OPEN	<ul style="list-style-type: none"> All functions stop. The operation with the remote controller, forced and test one do not operate.
	Connecting reversely	<ul style="list-style-type: none"> PWB pattern is damaged when applying the power.
RY-COMP terminal	OPEN	<ul style="list-style-type: none"> All functions stop or the compressor does not operate. The operation with the remote controller, forced and test one do not operate.
	Connecting reversely	<ul style="list-style-type: none"> All functions stop. The operation with the remote controller, forced and test one do not operate.
CN-TRANS	OPEN	<ul style="list-style-type: none"> All functions stop. The operation with the remote controller, forced and test one do not operate.
CN-FAN	OPEN	<ul style="list-style-type: none"> The Indoor Fan does not operate.
The connecting wire of CN-DC/DC, and Indoor and Outdoor Unit  ① Blue ② Black ③ Brown ④ Red	OPEN	<ul style="list-style-type: none"> All functions stop. The operation with the remote controller, forced and test one do not operate.
	Connecting error (① ↔ ②)	<ul style="list-style-type: none"> The only signal of remote controller operation/stop is inputted, but the product does not operate. The RED indicator of outdoor unit blinks 5 times after 2 minutes with applying the power.
	Connecting error (① ↔ ③)	<ul style="list-style-type: none"> The beep sound, such as "beep, beep, beep, beep, beep", occurs periodically in Indoor unit. The signal input of a remote controller and operation of product is impossible. The RED indicator blinks 5 times after 2 minutes with applying the power.
	Connecting error (① ↔ ④)	<ul style="list-style-type: none"> The signal of remote controller is inputted, but the product does not operate. The RED indicator of outdoor unit and the operation indicator of indoor one blinks 5 times after 2 minutes with applying the power.
	Connecting error (② ↔ ③)	<ul style="list-style-type: none"> No power for Indoor unit. The signal input of the remote controller and operation of product is impossible. The thermal protector of the Power Trans operates when let it alone for long time.
	Connecting error (② ↔ ④)	<ul style="list-style-type: none"> The signal of the remote controller is inputted. The fuse and Q61 in the Outdoor unit are damaged when the indoor fan is operated.
	Connecting error (③ ↔ ④)	<ul style="list-style-type: none"> No power for Indoor unit. The signal input of the remote controller and operation of product is impossible. The RED indicator of the Outdoor unit blinks 5 times after 2 minutes with applying the power.

9. Voltage of Connectors according to Indoor Fan Speed

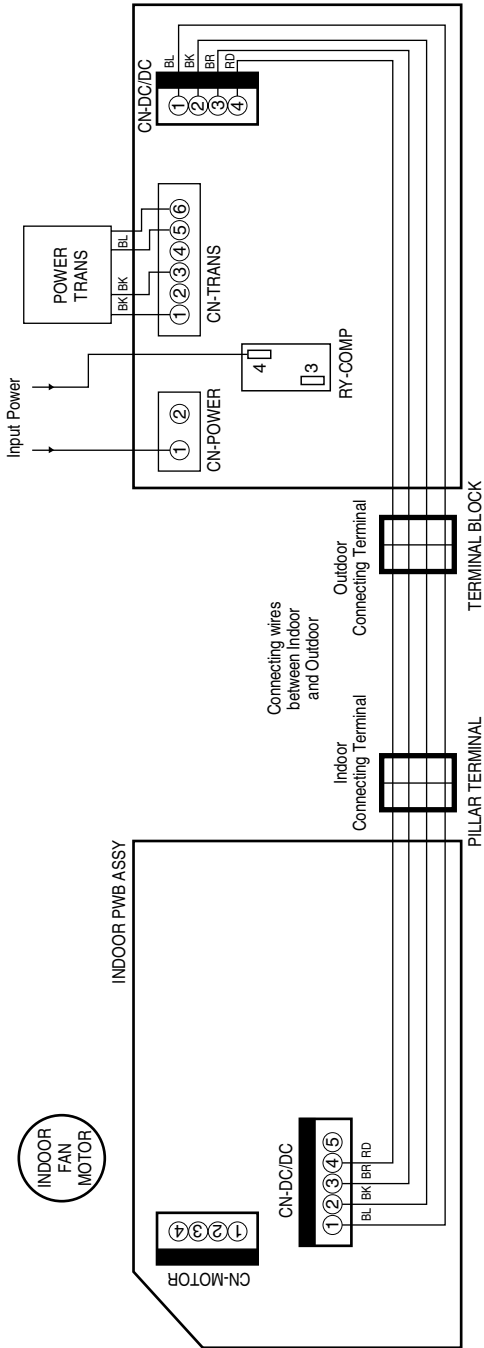

MODELS	No. of pins		12k			18k			24k					
	+	-	Hi	Med	Low	OFF	Hi	Med	Low	OFF	Hi	Med	Low	OFF
Indoor PWB Assy CN-MOTOR	①	②	25.8	23.2	20.0	0.0	27.5	24.6	22.1	0.0	34.0	30.8	27.5	0.0
	③	②	5.0	5.0	5.0	5.0	5.0	5.0	5.0	5.0	5.0	5.0	5.0	5.0
	④	②	0~5	0~5	0~5	5.0	0~5	0~5	0~5	5.0	0~5	0~5	0~5	5.0
	④	③	0~12	0~12	0~12	0~12	0~12	0~12	0~12	0~12	0~12	0~12	0~12	0~12
Indoor Pillar Terminal	②	③	17.0	17.0	17.0	17.0	17.0	17.0	17.0	17.0	17.0	17.0	17.0	17.0
	①	③	25.8	23.2	20.2	0.0	27.5	24.6	22.1	0.0	0.0	34.0	27.5	0.0
	④	③	0~12	0~12	0~12	0~12	0~12	0~12	0~12	0~12	0~12	0~12	0~12	0~12
Outdoor Terminal Block	②	③	17.0	17.0	17.0	17.0	17.0	17.0	17.0	17.0	17.0	17.0	17.0	17.0
	①	③	26.2	23.5	20.3	0.0	28.2	25.2	22.6	0.0	0.0	34.9	28.2	0.0
	④	③	0~12	0~12	0~12	0~12	0~12	0~12	0~12	0~12	0~12	0~12	0~12	0~12

Electronic Control Device

(1) MAIN PWB ASSY(Indoor Unit)

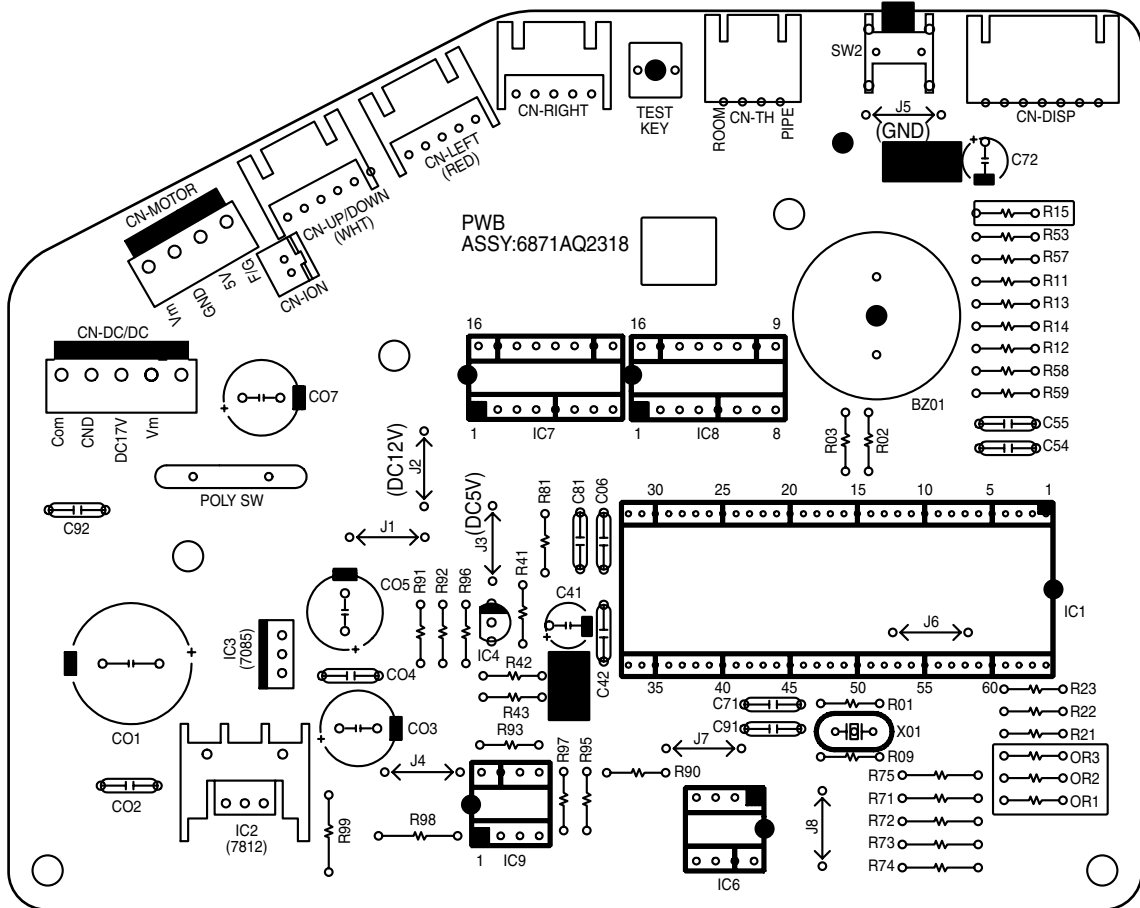

• PWB ASSY SVC PART LIST

NO	MODEL	P/No.	OPTIONAL FUNCTION				
			OR1	OR2	OR3	R15	SW2
1	12k Heating Model	2011-0002	91K	39K	OPEN	OPEN	KPT-1112
2	9k, 12k Cooling Model	2011-0001	5.1K	39K	OPEN	10K	KPT-1112
3	18k/24k Heating Model	2011-0004	91K	10K	OPEN	OPEN	KPT-1122A
4	18k/24k Cooling Model	2011-0003	5.1K	10K	OPEN	OPEN	KPT-1122A

(2) MAIN PWB ASSY(Outdoor Unit)

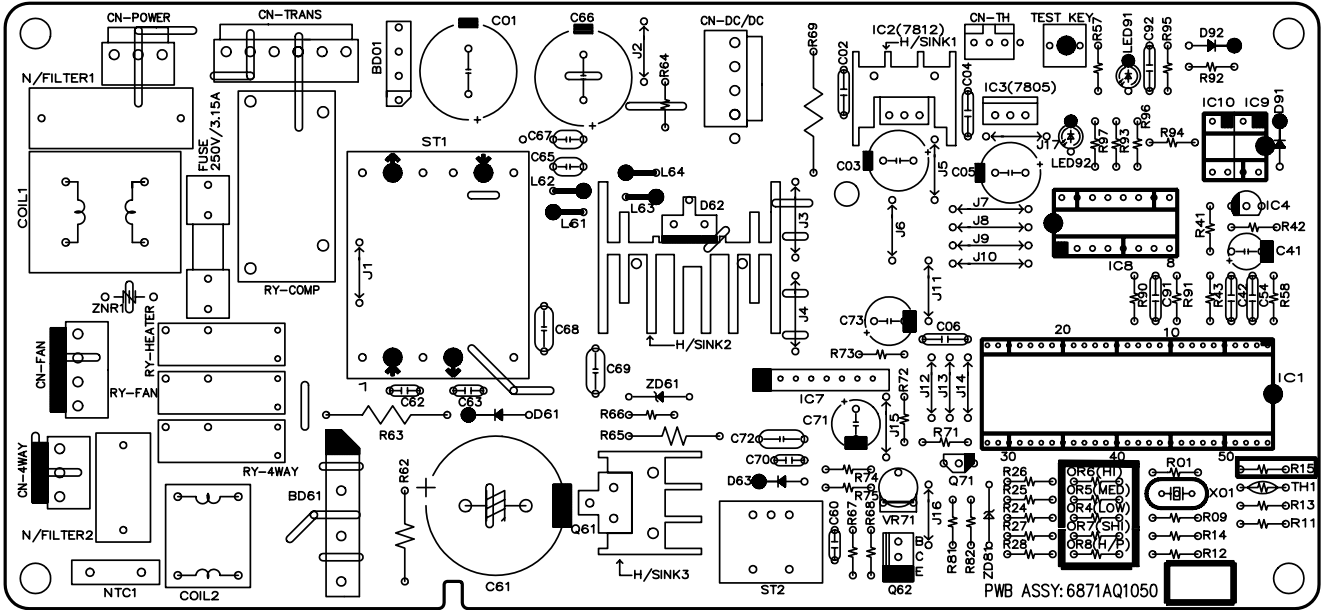

• PWB ASSY SVC PART LIST

NO	MODEL	P/No.	OPTIONAL FUNCTION													
			OR4	OR5	OR6	OR7	OR8	R15	R81	FUSE	RY-HEATER	RY-4WAY	RY-FAN	CN-4WAY	CN-FAN	CN-TH
1	12k Heating Model	2011-0010	20K	20K	15K	OPEN	6.8K	OPEN	36.7K	250V 3.15A	O	O	O	O	O	
2	12k Cooling Model	2011-0009	20K	20K	15K			10K			X	X	X	X	X	X
	9k Cooling Model	2011-0017	12K	6.8K	3K			10K			X	X	X	X	X	X
3	18k Heating Model	2011-0008	20K	27K	20K			OPEN			O	O	O	O	O	O
4	18k Cooling Model	2011-0007	20K	27K	20K			10K			X	X	O	X	O	X
5	24k Heating Model	2011-0006	56K	91K	56K			OPEN			O	O	O	O	O	O
6	24k Cooling Model	2011-0005	56K	91K	39K	10K	X	X	O	X	O	X				

(3) DISPLAY PWB ASSY

< 9k, 12k >

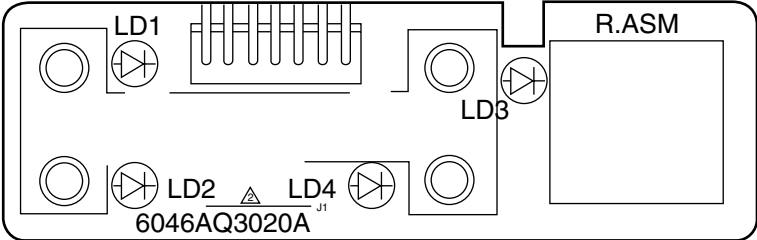

(P/No: 6047AQ3021E)

< 18k, 24k >

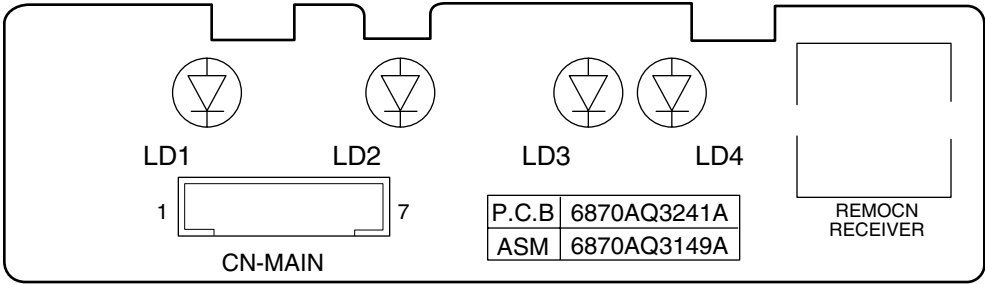

(P/No: 6871AQ3149A)

Schematic Diagram

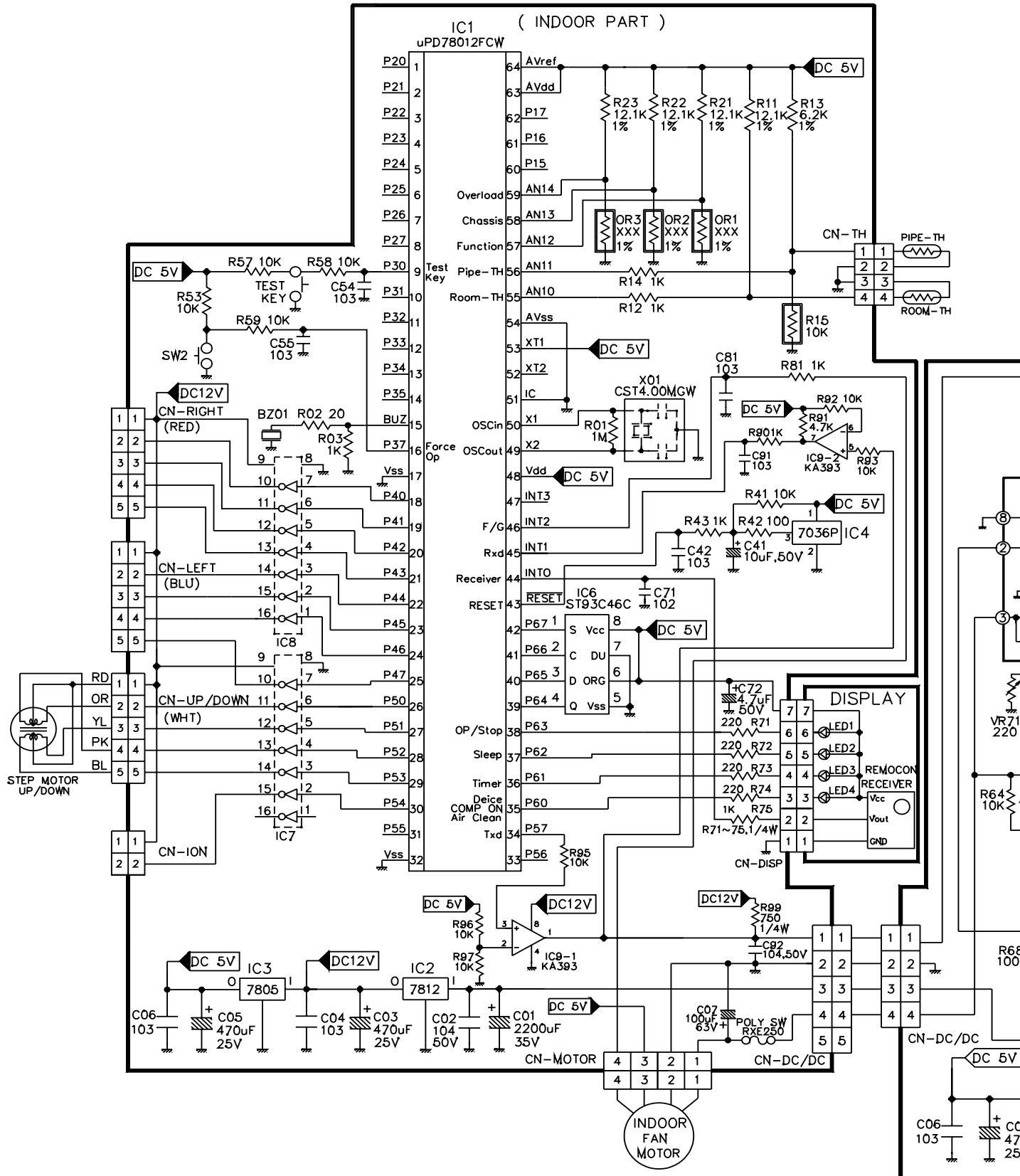

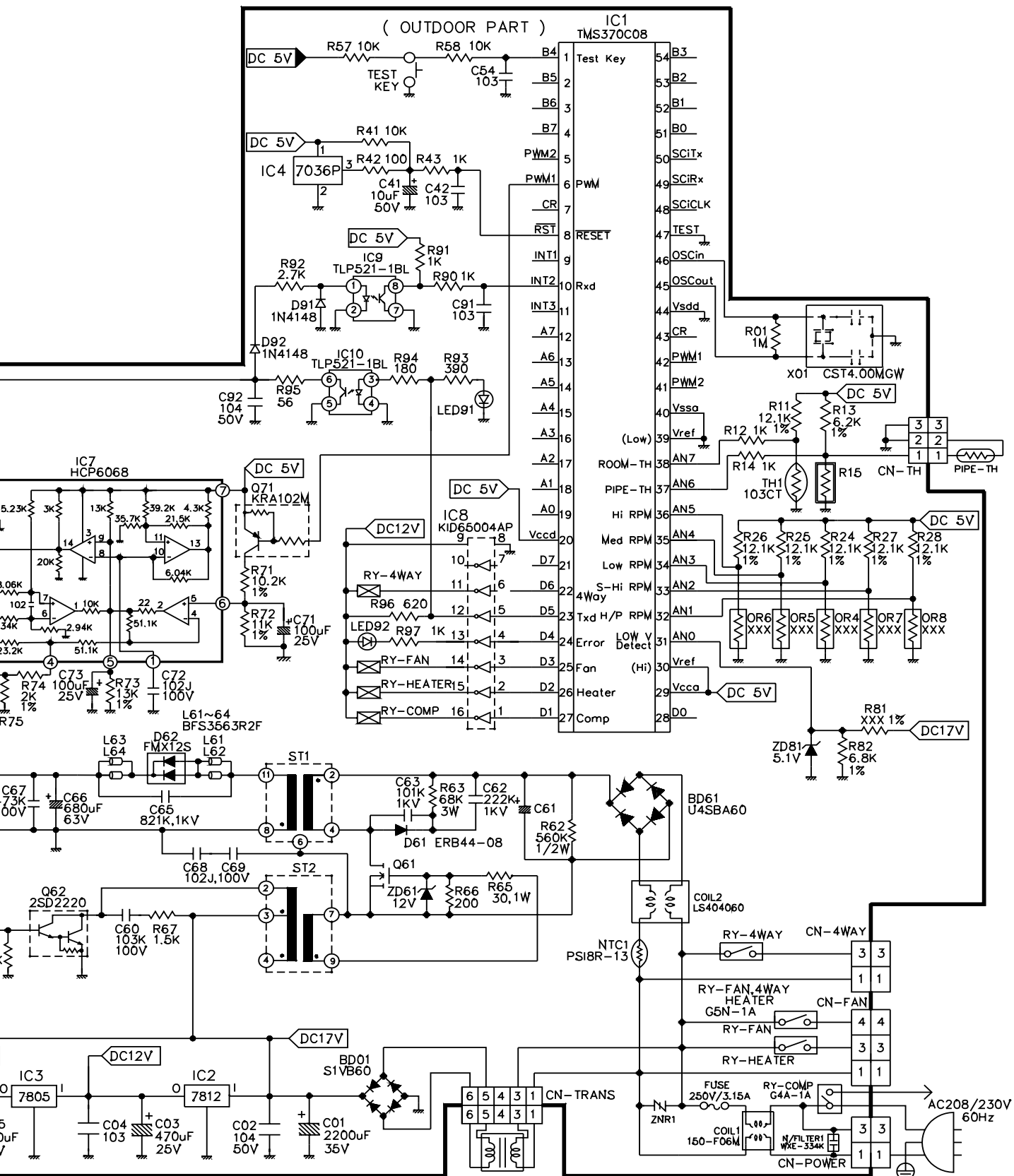

Exploded View

1. Indoor Unit (9k, 12k)

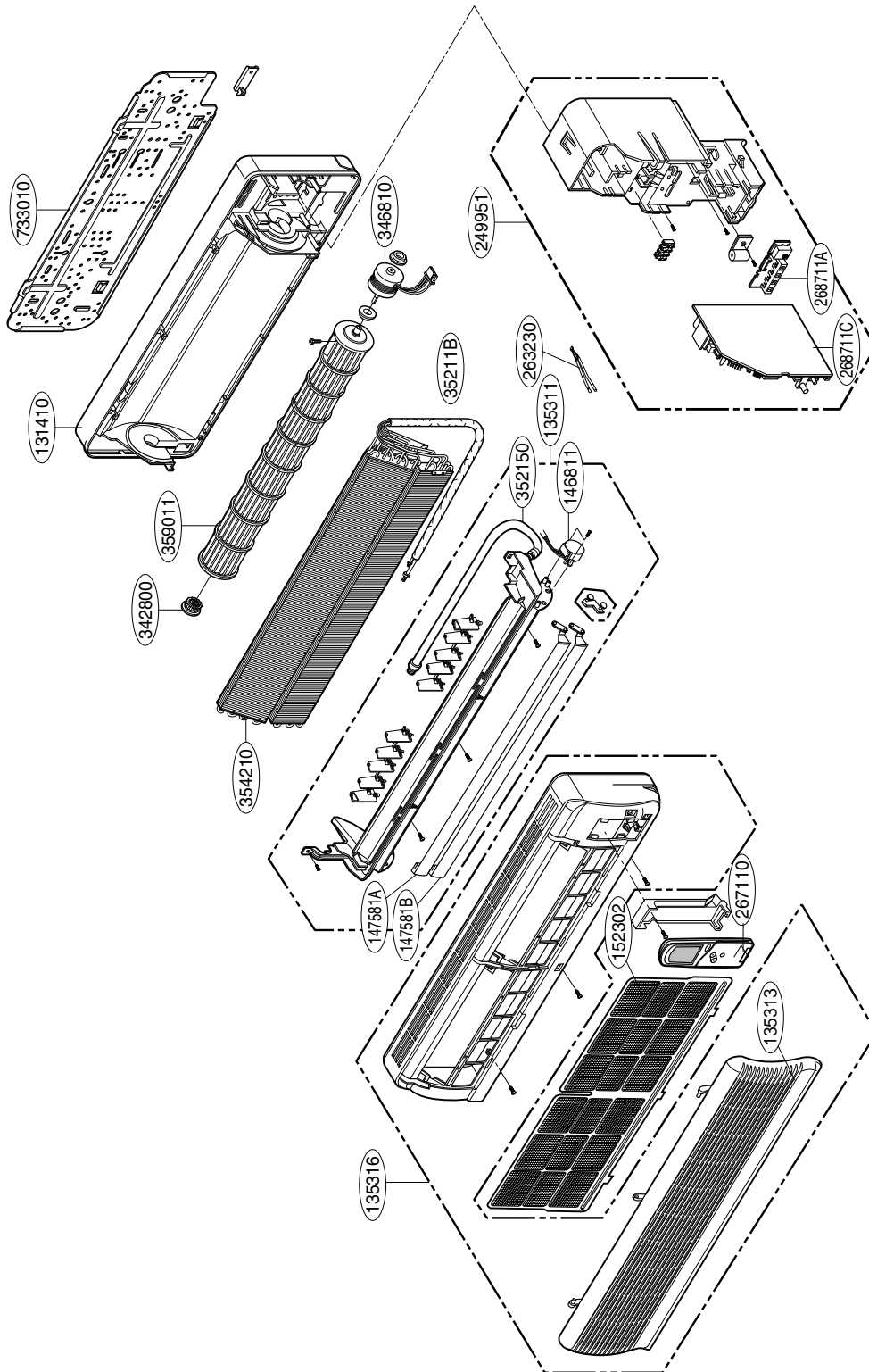

2. Indoor Unit(18k, 24k)

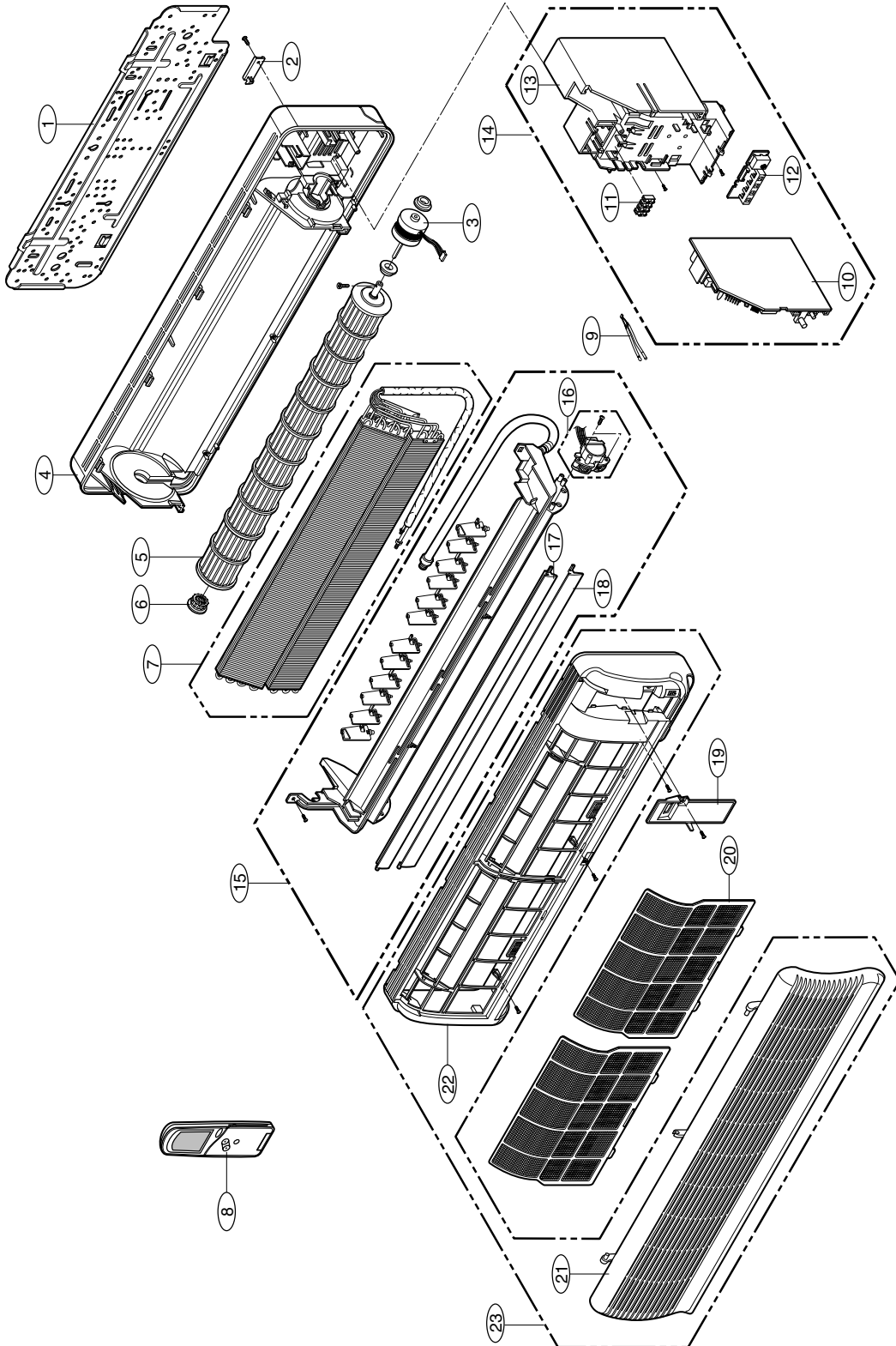

3. Outdoor Unit(9k, 12k)

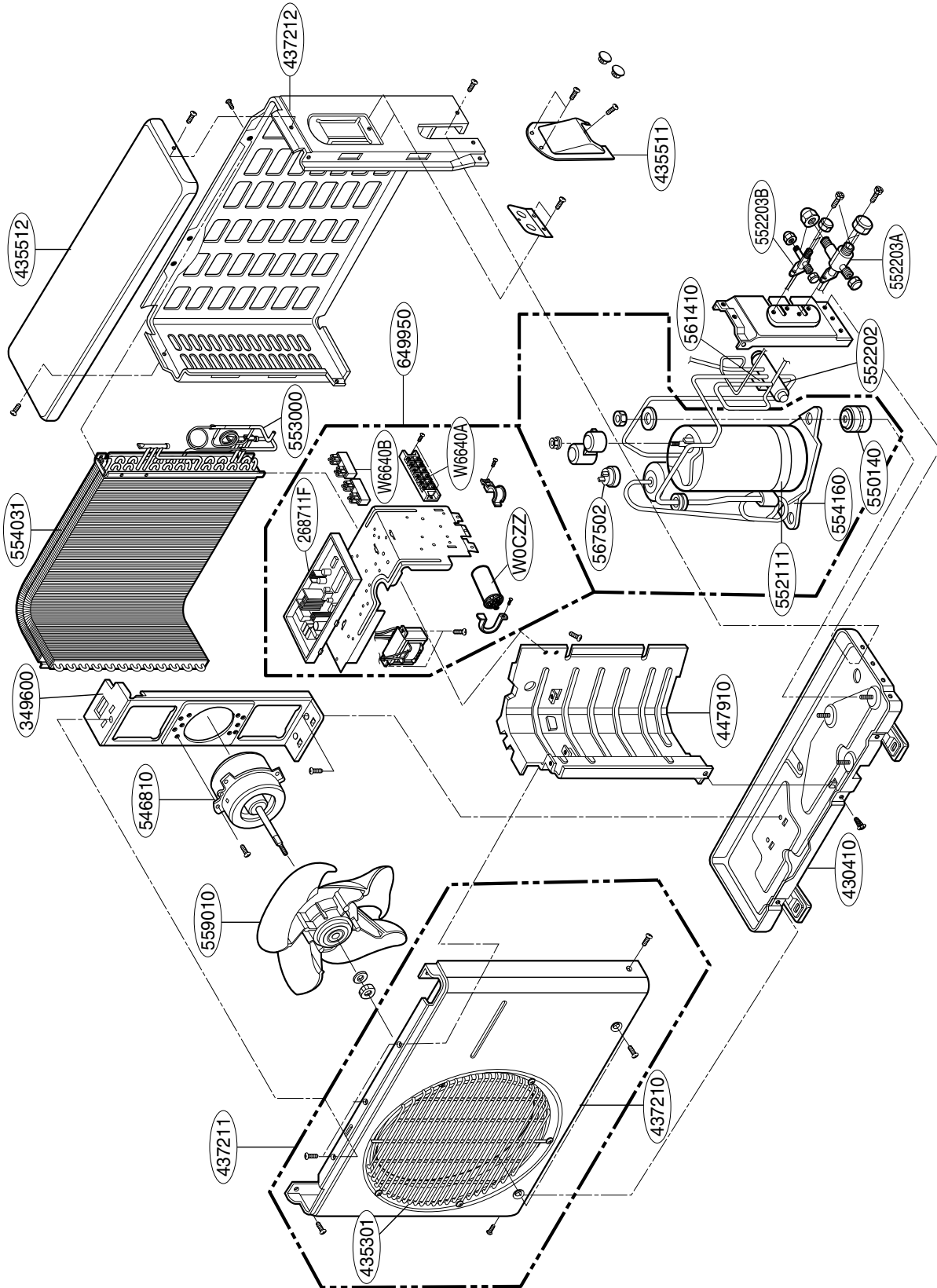

4. Outdoor Unit(18k)

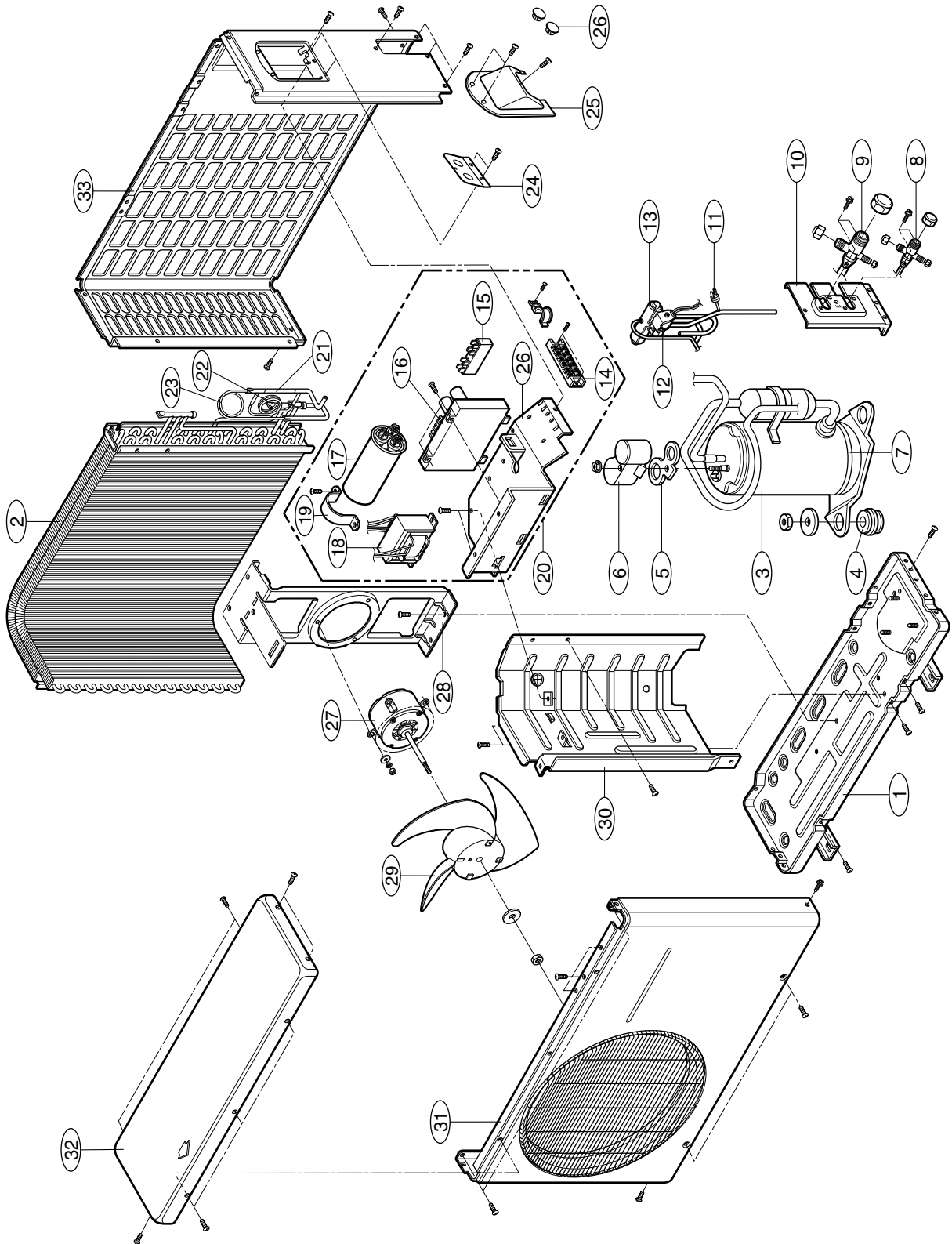

5. Outdoor Unit(24k)

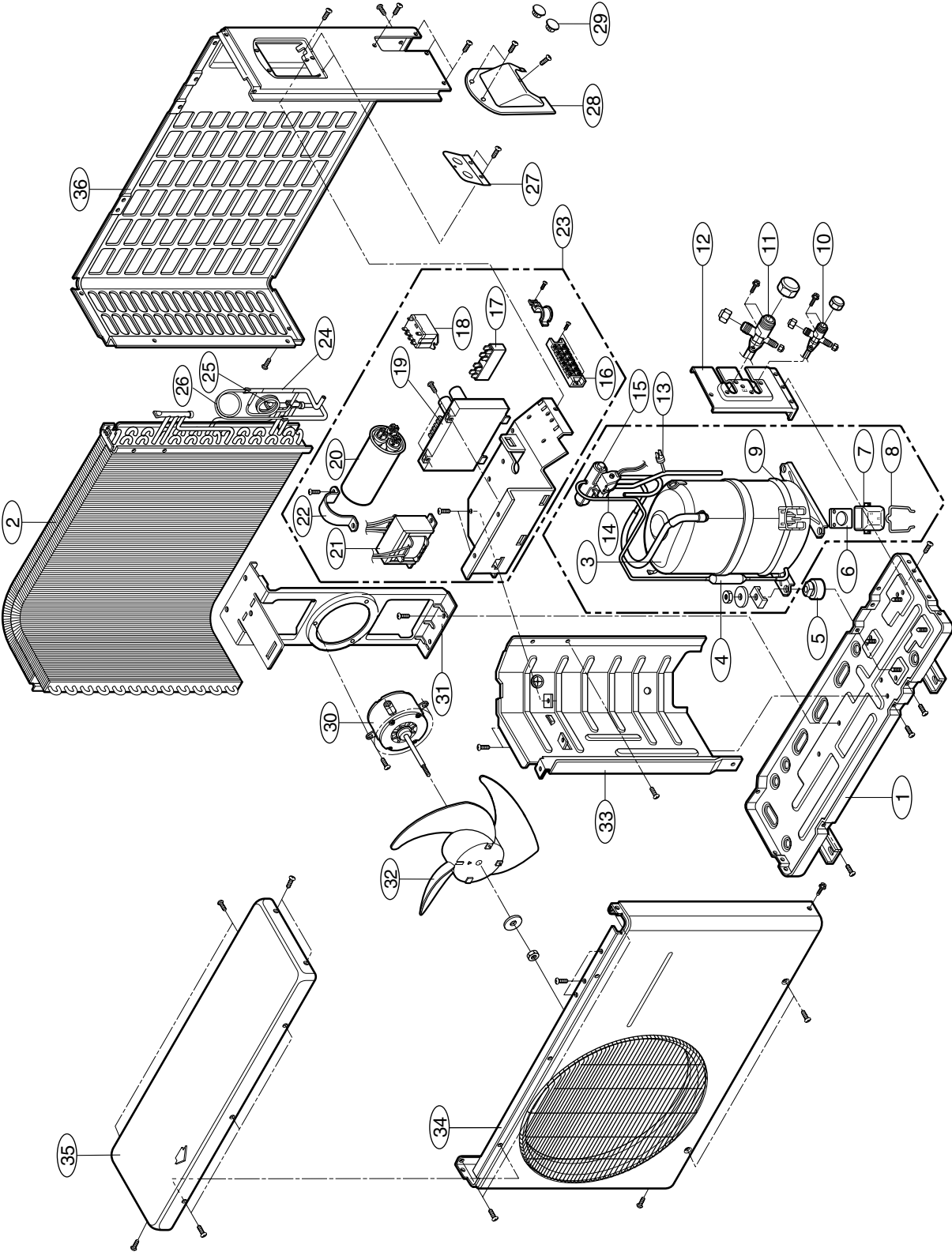

Specifications and performance data subject to change without notice.

HEAT CONTROLLER, INC.

1900 WELLWORTH AVENUE • JACKSON, MICHIGAN 49203

THE QUALITY LEADER IN CONDITIONING AIR