

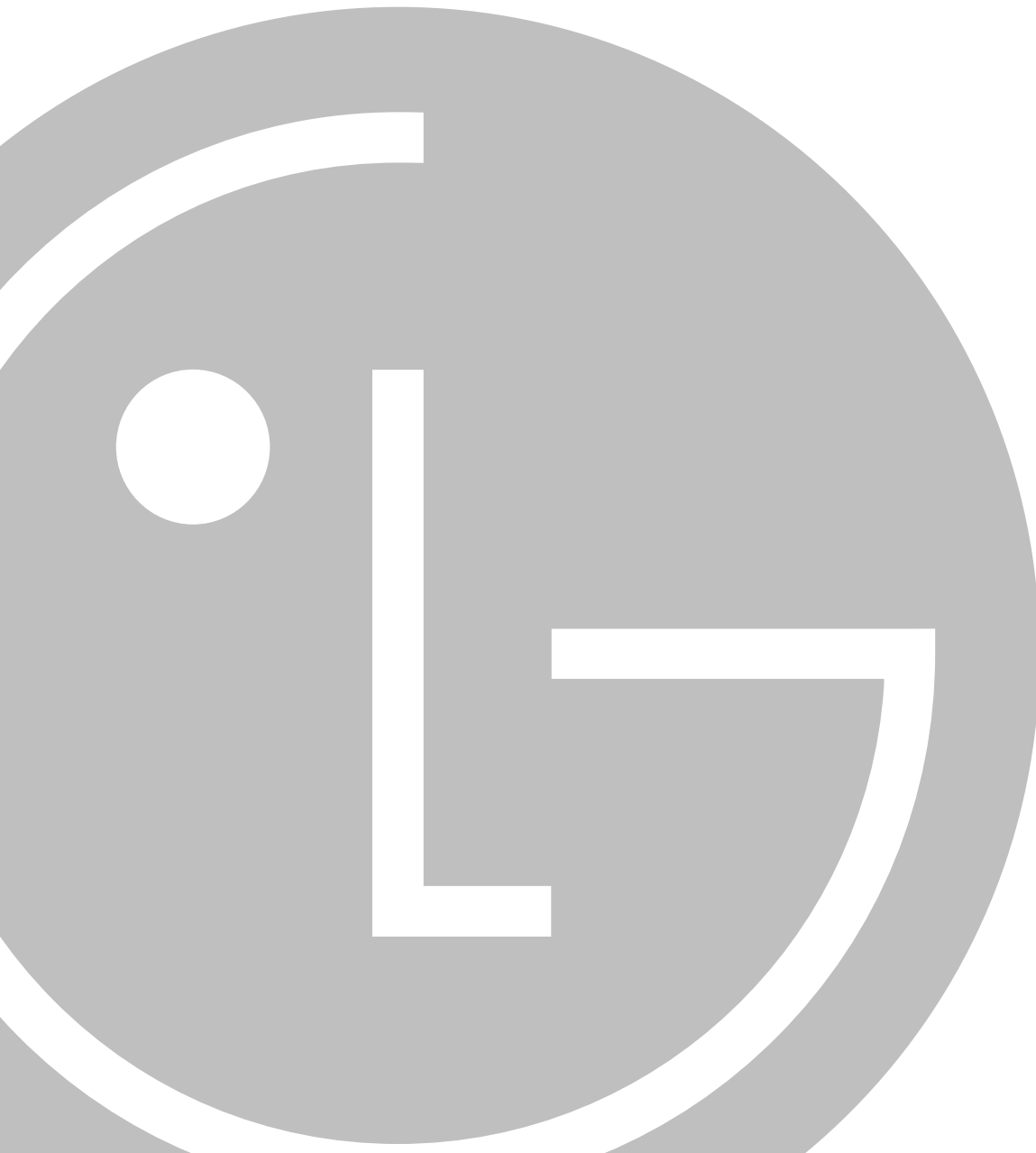

# Floor Standing Type Air Conditioner **SERVICE MANUAL**

**MODEL: LF300CP(LP-C303R20)  
LF480CE(LP-C483TA0)**



# Contents

---

<b>Safety Precautions .....</b>	<b>3</b>
<b>Functions .....</b>	<b>7</b>
<b>Product Specifications .....</b>	<b>10</b>
<b>Dimensions .....</b>	<b>11</b>
<b>Wiring Diagram.....</b>	<b>15</b>
<b>Operation Details .....</b>	<b>17</b>
<b>Installation of Indoor, Outdoor Unit.....</b>	<b>23</b>
<b>Test Running .....</b>	<b>25</b>
<b>Cycle Troubleshooting Guide.....</b>	<b>27</b>
<b>Electronic Parts Troubleshooting Guide.....</b>	<b>28</b>
<b>Exploded View and Replacement Parts List.....</b>	<b>29</b>

# Safety Precautions

To prevent injury to the user or other people and property damage, the following instructions must be followed.

■ Incorrect operation due to ignoring instruction will cause harm or damage. The seriousness is classified by the following indications.

**⚠ WARNING** This symbol indicates the possibility of death or serious injury.

**⚠ CAUTION** This symbol indicates the possibility of injury or damage to properties only.

■ Meanings of symbols used in this manual are as shown below.

	<b>Be sure not to do.</b>
	<b>Be sure to follow the instruction.</b>

## ⚠ WARNING

### ■ Installation

**Do not use a defective or underrated circuit breaker. Use this appliance on a dedicated circuit.**

- There is risk of fire or electric shock.

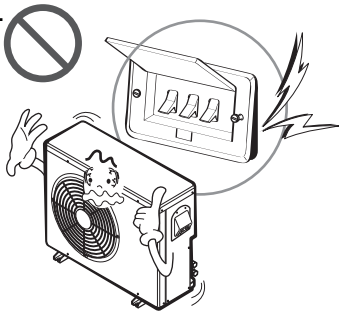

**Always ground the product.**

- There is risk of fire or electric shock.

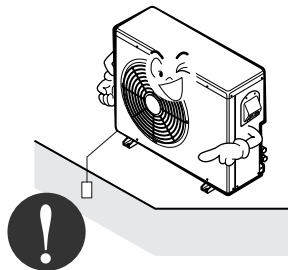

**Install the panel and the cover of control box securely.**

- There is risk of fire or electric shock.

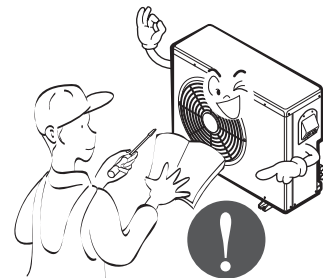

**Always install a dedicated circuit and breaker.**

- Improper wiring or installation may cause fire or electric shock

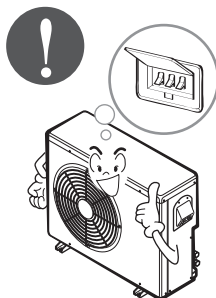

**Use the correctly rated breaker or fuse.**

- There is risk of fire or electric shock.

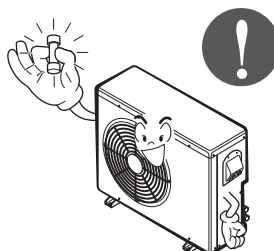

**Do not modify or extend the power cable.**

- There is risk of fire or electric shock.

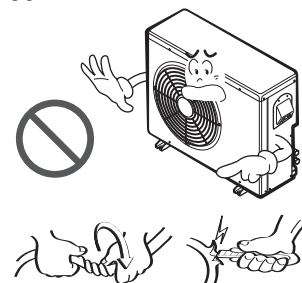

**Do not install, remove, or re-install the unit by yourself (customer).**

- There is risk of fire, electric shock, explosion, or injury.

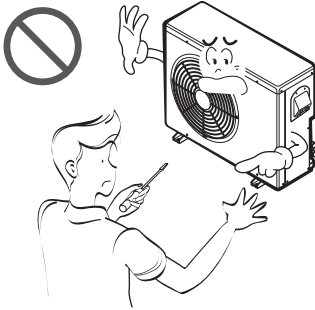

**Be cautious when unpacking and installing the product.**

- Sharp edges could cause injury. Be especially careful of the case edges and the fins on the condenser and evaporator.

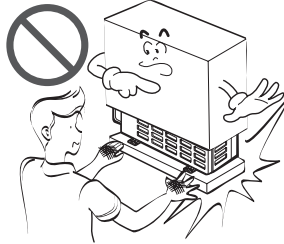

**For installation, always contact the dealer or an Authorized Service Center.**

- There is risk of fire, electric shock, explosion, or injury.

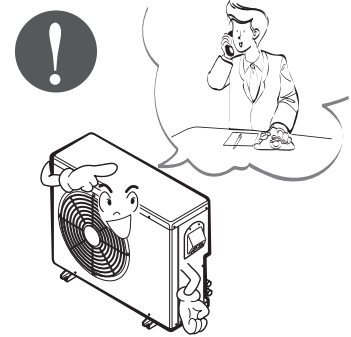

**Do not install the product on a defective installation stand.**

- It may cause injury, accident, or damage to the product.

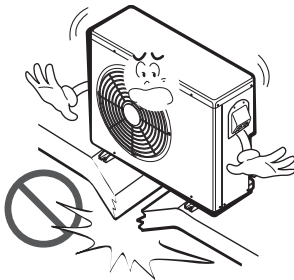

**Be sure the installation area does not deteriorate with age.**

- If the base collapses, the air conditioner could fall with it, causing property damage, product failure, and personal injury.

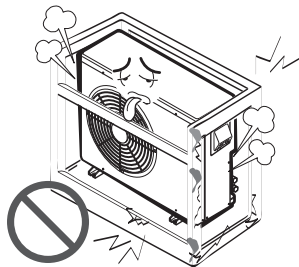

**Do not let the air conditioner run for a long time when the humidity is very high and a door or a window is left open.**

- Moisture may condense and wet or damage furniture.

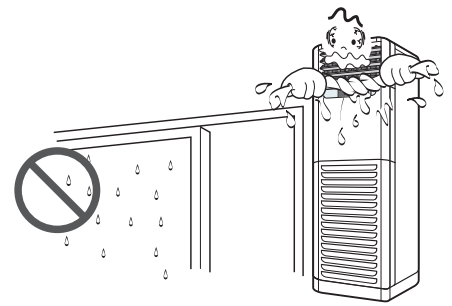

## ■ Operational

**Do not touch (operate) the product with wet hands.**

- There is risk of fire or electrical shock.



**Do not place a heater or other appliances near the power cable.**

- There is risk of fire or electric shock.

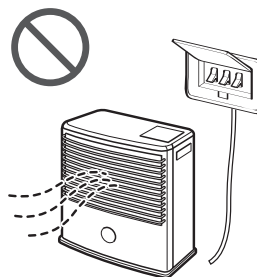

**Do not let electric parts of the product get wet.**

- There is risk of fire, failure of the product, or electric shock.

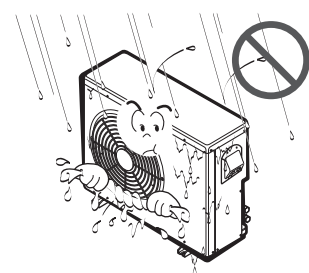

**Do not store or use flammable gas or combustibles near the product.**

- There is risk of fire or failure of product.

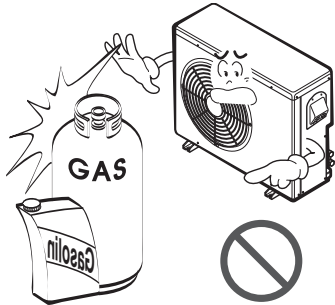

**If strange sounds, or small or smoke comes from product. Turn the breaker off or disconnect the power supply cable.**

- There is risk of electric shock or fire.

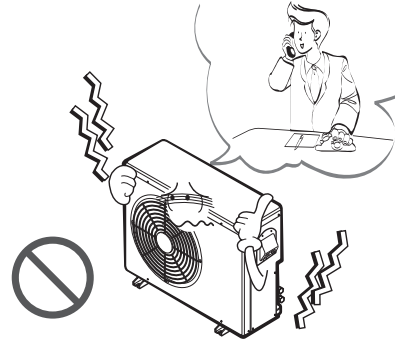

**Do not open the inlet grill of the product during operation. (Do not touch the electrostatic filter, if the unit is so equipped.)**

- There is risk of physical injury, electric shock, or product failure.

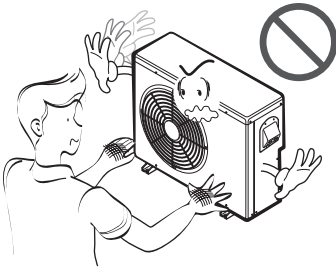

**Be cautious that water could not enter the product.**

- There is risk of fire, electric shock, or product damage.

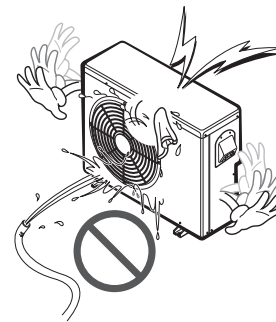

## **⚠ CAUTION**

### **■ Installation**

**Always check for gas (refrigerant) leakage after installation or repair of product.**

- Low refrigerant levels may cause failure of product.

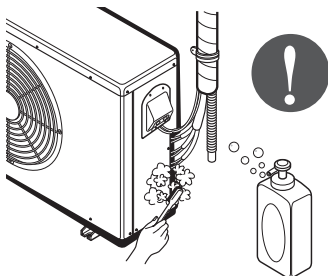

**Install the drain hose to ensure that water is drained away properly.**

- A bad connection may cause water leakage.

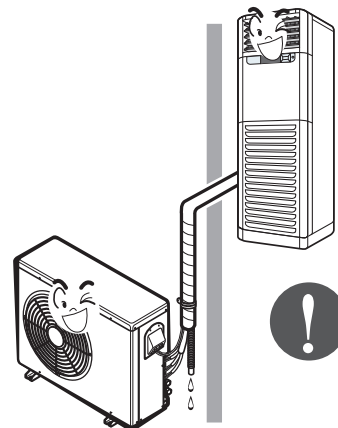

**Keep level even when installing the product.**

- To avoid vibration or water leakage.

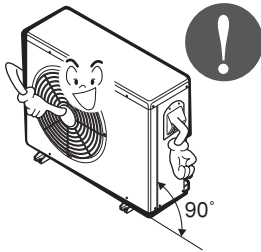

**Use two or more people to lift and transport the product.**

- Avoid personal injury.

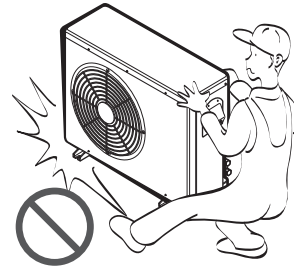

**Operational**

**Use a soft cloth to clean. Do not use harsh detergents, solvents, etc.**

- There is risk of fire, electric shock, or damage to the plastic parts of the product.



**Do not touch the metal parts of the product when removing the air filter. They are very sharp!**

- There is risk of personal injury.

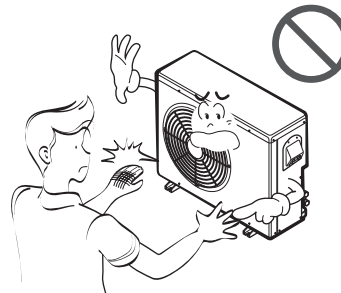

**Do not step on or put anything on the product. (outdoor units)**

- There is risk of personal injury and failure of product.



**Do not insert hands or other objects through the air inlet or outlet while the product is operated.**

- There are sharp and moving parts that could cause personal injury.

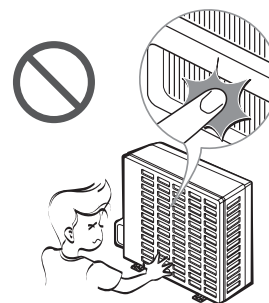

# Functions

---

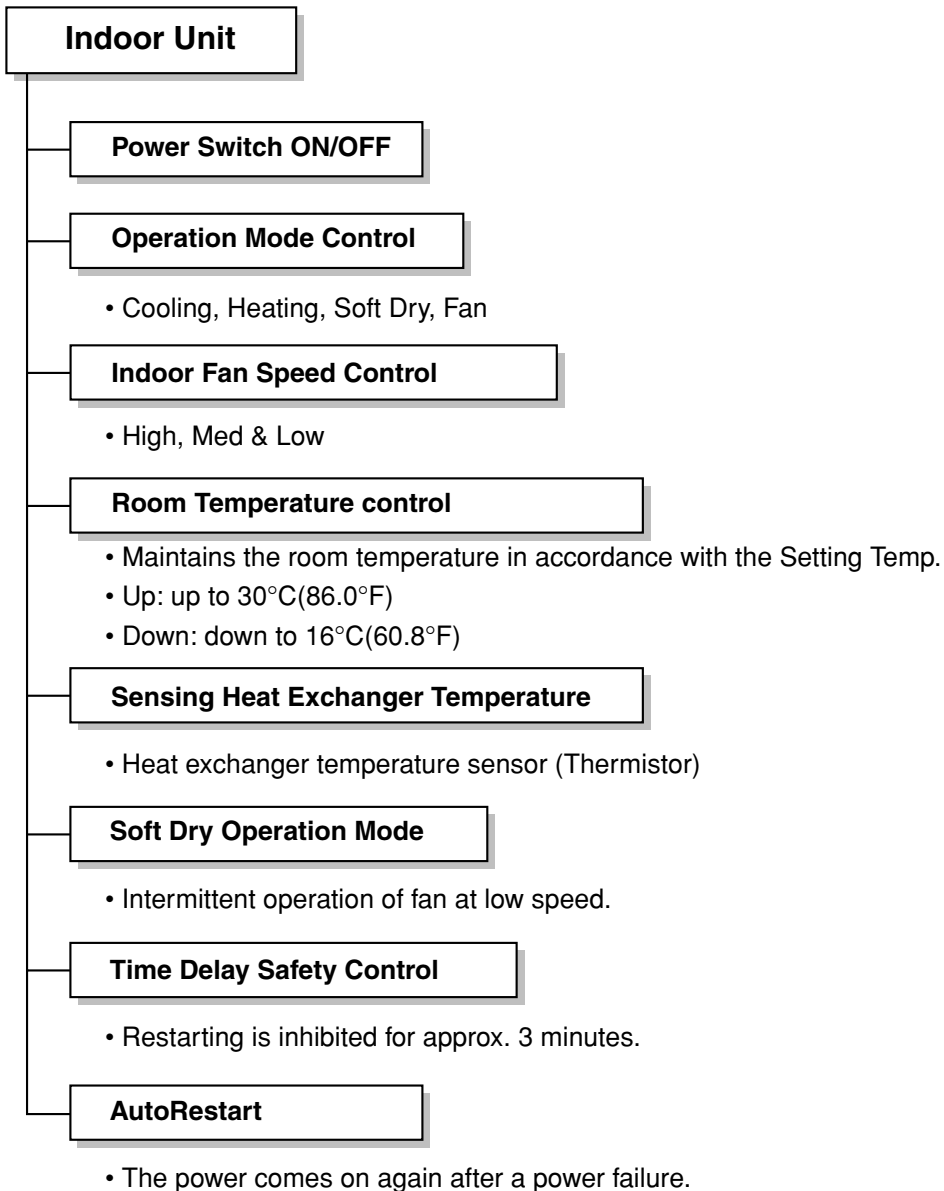

## Remote Control

### Operation ON/OFF

### Cooling Operation Mode

### Heating Operation Mode

### Sot Dry Operation Mode

- Intermittent operation of fan at low speed.

### Fan Operation

- Used to circulate room air without cooling.

### Timer Control

- OFF Timer (1, 2, 3,.....7 hour)

### Airflow Direction Control

- Airflow direction Auto-swing and Manual Control.

### Room Temperature Control

- Up: up to 30°C(86.0°F)
- Down: down to 16°C(60.8°F)

### Indoor Fan speed control

- High, Med & Low

## Outdoor Unit

### Deice Control (Heating Model Only)

- De-ice PCB

### Outdoor Fan Speed Control

- One speed

### Sensing Heat Exchanger Temperature

- Heat exchanger temperature sensor (Thermistor)

# Product Specifications

MODEL			LF300CP(LP-C303R20)	LF480CE(LP-C483TA0)
POWER SOURCE (ø, V, Hz)			1, 208/230, 60	1, 208/230, 60
COOLING	CAPACITY	Btu/h	28,000	48,000
		W	8,206	14,067
	INPUT	W	2,600	4,500
	CURRENT	A	11.5	20
HEATING	CAPACITY	Btu/h	-	-
		W	-	-
	INPUT	W	-	-
	CURRENT	A	-	-
COMPRESSOR	MAKER		LG	LG
	TYPE		Rotary	Rotary
	MODEL		QJ250KAB/QK145KBD	QP325KBD * 2
	CAPACITY	Btu/h	17,658/10,100	24000
	CURRENT	A	7.7/4.5	10.2
	INPUT	W	1,635/935	2162
NOISE LEVEL(1m)	INDOOR	dB(A)	50/45/39/32	57/54/51
	OUTDOOR		56	62
AIR VOLUME	INDOOR	CMM (CFM)	20/16.5/13/6 (706/583/459/212)	35/33/30(1,236/1,165/1,059)
	OUTDOOR		47 (1,660)	104(3,672)
REFRIGERANT R-22		Kg(Oz)	1.84 (65)	3.92(124.2)
HEAT EXCHANGER	INDOOR	R/C/FPI	2R/30C/18FPI	3R/28C/18FPI
	OUTDOOR	R/C/FPI	2R/36C/20FPI	2R/26C/21FPI
FAN	INDOOR	TYPE	TURBO FAN	TURBO FAN
	OUTDOOR		Propeller	Propeller
ROOM TEMPERATURE CONTROL			Thermistor	Thermistor
NET WEIGHT	INDOOR	Kg(lbs)	32(70.5)	58(127.9)
	OUTDOOR		66(145.5)	90(198.4)
Gross Weight	INDOOR	Kg(lbs)	38(83.8)	66(145.5)
	OUTDOOR		71(156.5)	100(220.5)
DIMENSIONS (W ¥ H ¥ D)	INDOOR	mm (Inch)	570 x 1,820x 310 (22.45 x 71.7 x 12.2)	590 x 1,810 x 440 (23.23 x 71.26 x 17.32)
	OUTDOOR		870 x 808 x 320 (34.3 x 31.8 x 12.6)	900 x 1,225 x 370 (35.43 x 48.23 x 14.57)
SVC VALVE	LIQUID	mm (Inch)	9.52(3/8)	9.52(3/8)
	GAS		15.88(5/8)	19.05(3/4)
POWER CABLE		P*mm <sup>2</sup>	3x4.0	3x5.5
CONNECTING CABLE		P*mm <sup>2</sup>	4x1.0	4x1.0
BREAKER CAPACITY		A	20	40

# Dimensions

## Indoor Unit: LPNC303R20 (LF300CP)

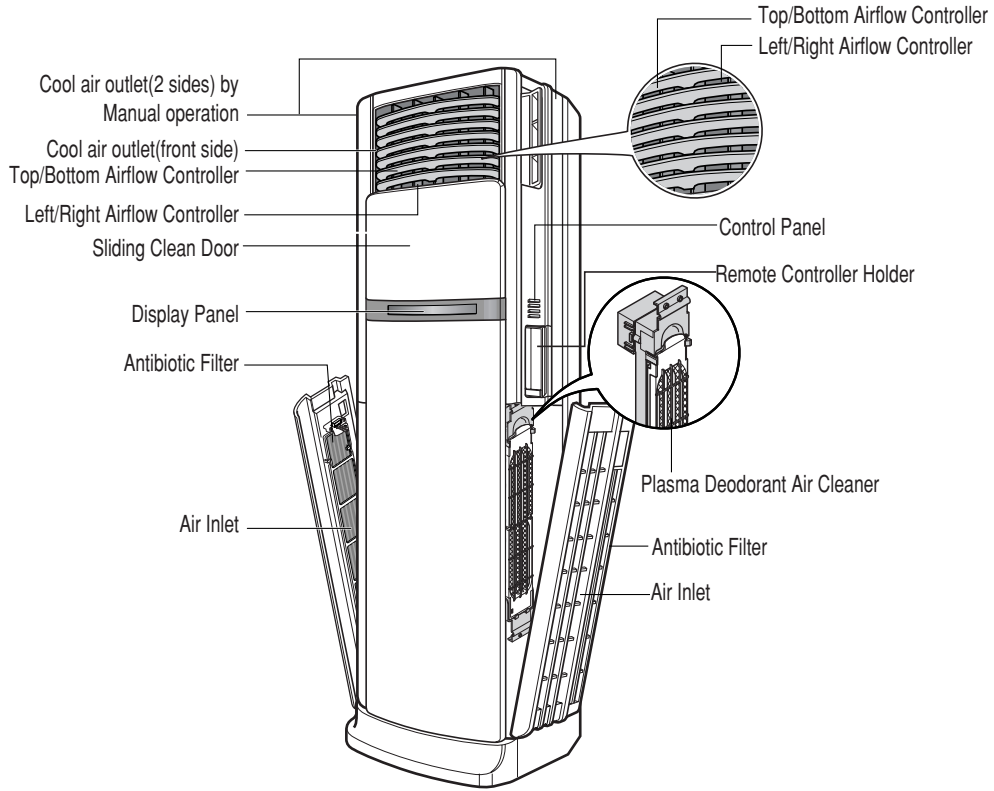

## Outdoor Unit : LPUC303R20 (LF300CP)

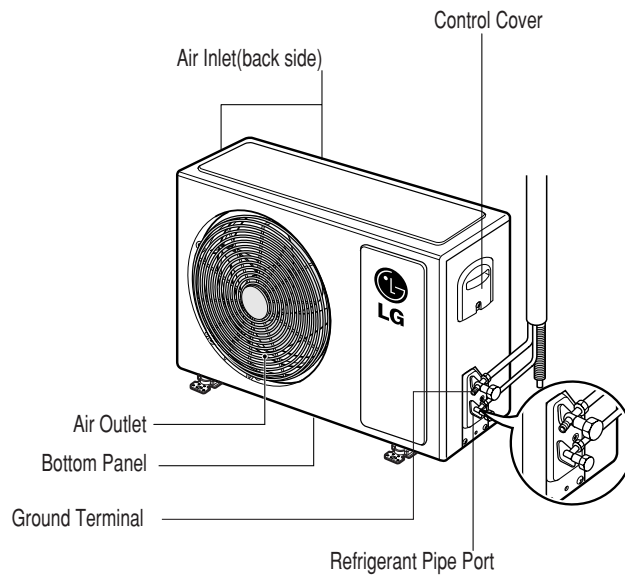

## Indoor Unit

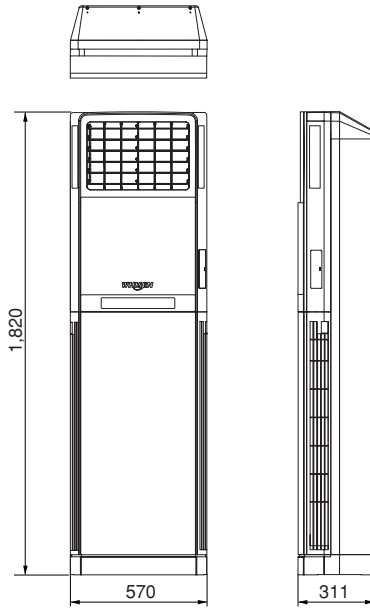

No.	Items
1	Control Display
2	Air outlet vent
3	Air inlet vent

## Outdoor Unit

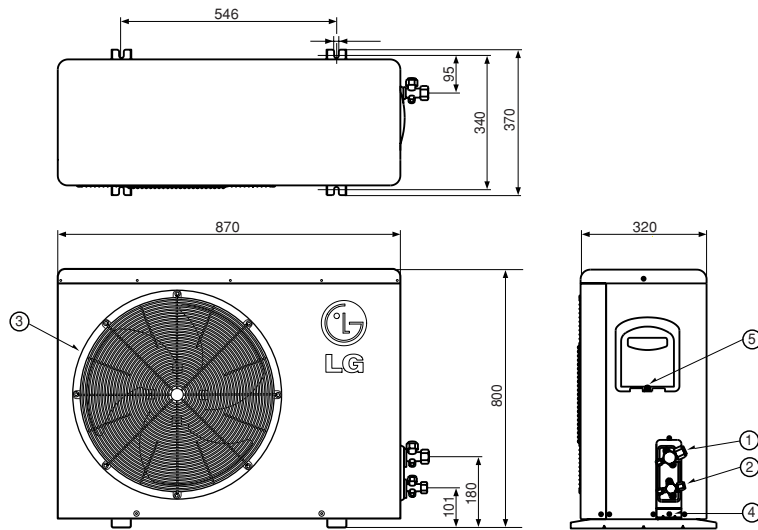

No.	Items
1	Gas side service valve (Ø 15.88)
2	Liquid side service valve (Ø 9.52)
3	Fan cover
4	Earth screw
5	Connecting cable hole

**Indoor Unit : LPNC483TA0 (LF480CE)**

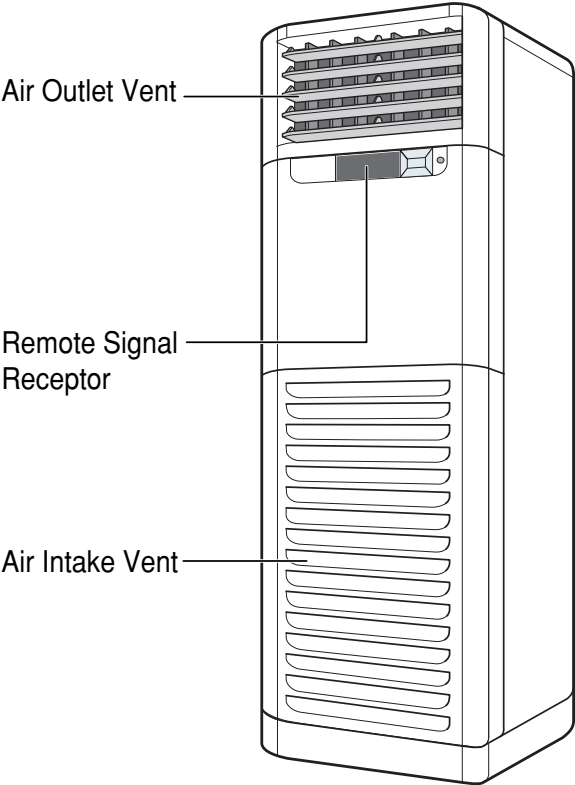

**door Unit : LPUC483TA0 (LF480CE)**

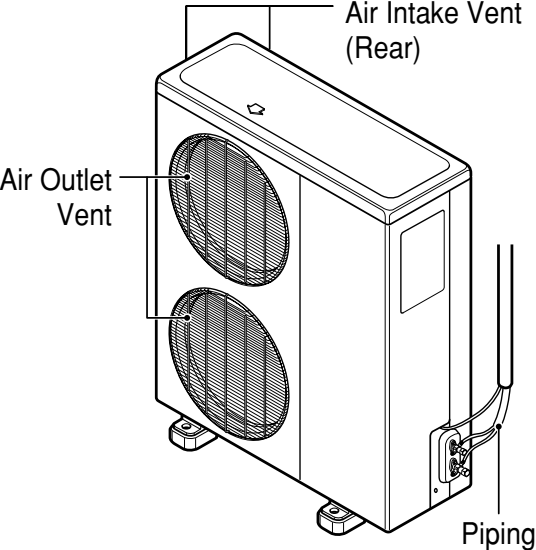

## Indoor Unit

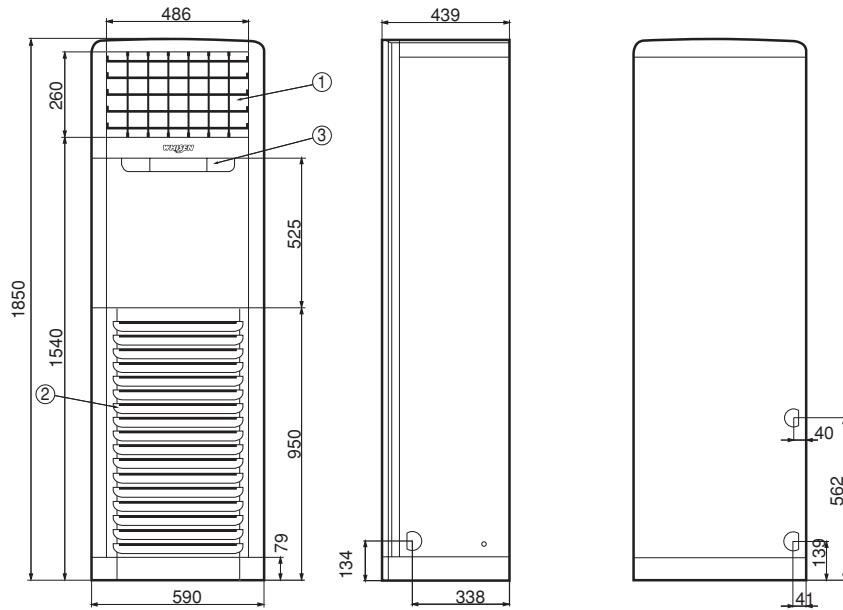

No.	Items
1	Air Outlet Vent
2	Air Inlet Vent
3	Control display

## Outdoor Unit

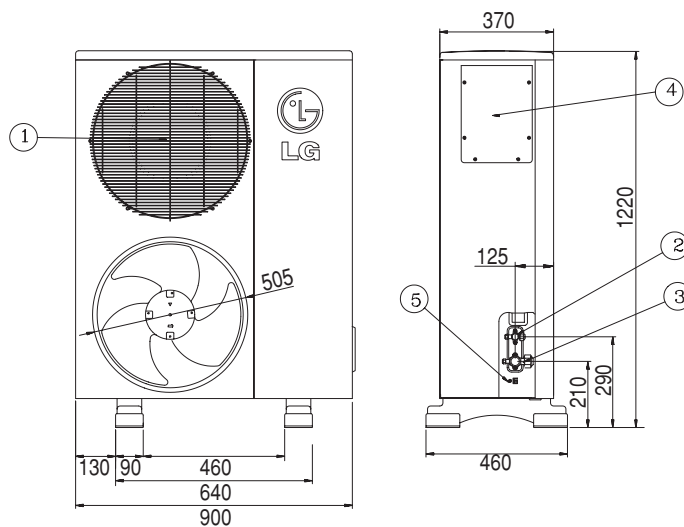

No.	Items
1	Air Outlet Vent
2	Liquid Side SVC Valve(Ø 9.52)
3	Gas Side SVC Valve(Ø 19.05)
4	Control Box
5	Earth Screw

# Wiring Diagram

## 1. LF300CP(LP-C303R20)

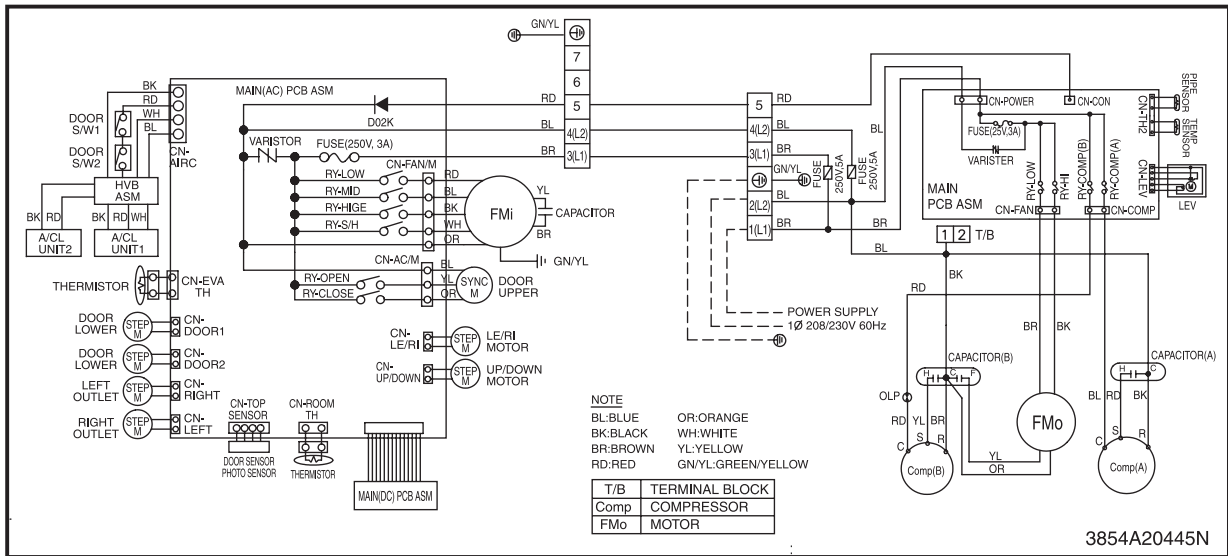

## Outdoor

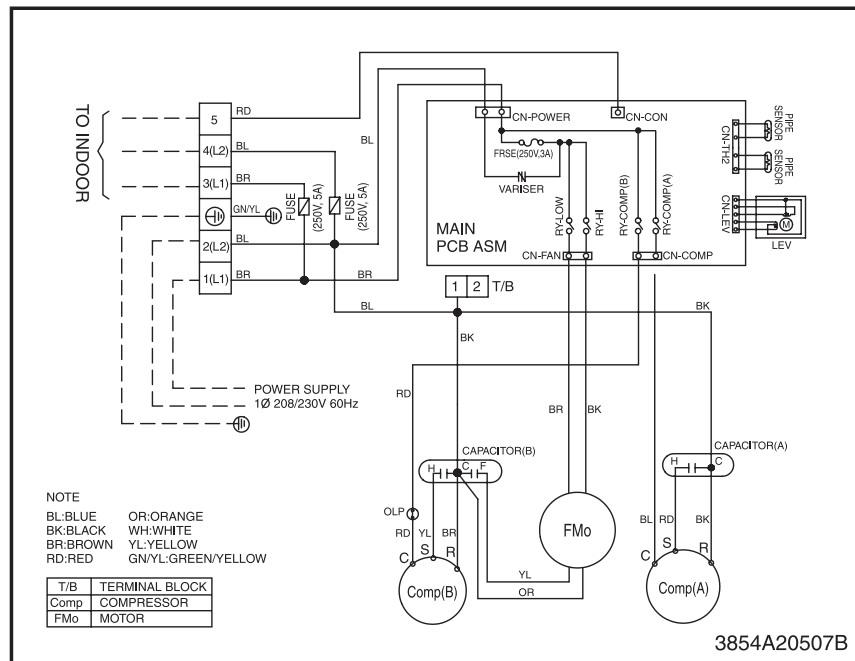

## 2. LF480CE(LP-C483TA0)

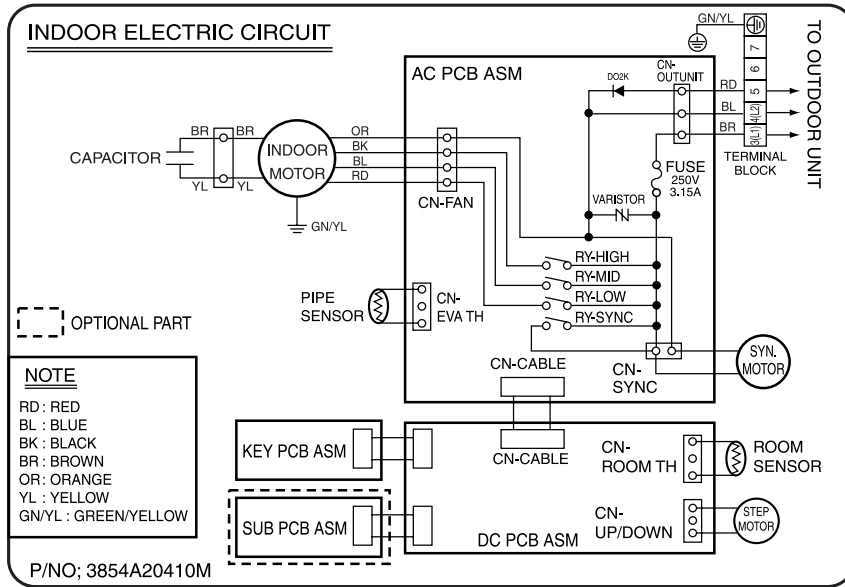

## Outdoor

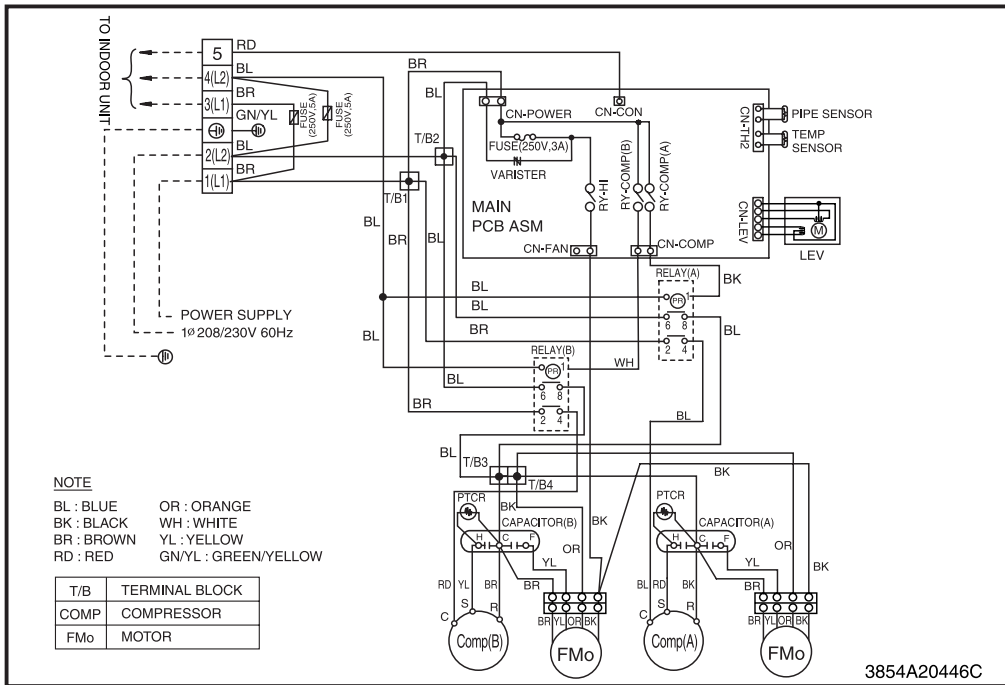

# Operation Details

## 1. Time Delay Safety Control

- 3min... The compressor is ceased for 3 minutes to balance the pressure in the refrigeration cycle.  
(Protection of compressor)
- 3sec... The indoor fan is ceased for 3 seconds to prevent relay noise.  
(Protection of fan relay and micro chip)
- 30sec... The 4-way valve is ceased for 30 sec. to prevent the refrigerant-gas abnormal noise when the Heating operation is OFF or switched to the other operation mode.

## 2. Airflow Direction Control

- This function is to swing the louver left and right automatically and to set it at the desired position.
- The procedure is as the following.
  - 1st : Press the ON/OFF Button to operate the product.
  - 2nd : Press the Airflow Direction Control Button to swing the louver left and right automatically.  
(Remote controller)
  - 3rd : Re-press the Airflow Direction Control Button to set the louver as the desired position.  
(Remote controller)

## 3. Cooling Mode Operation

- When selecting the Cooling(❄) Mode Operation, the unit will operate according to the setting by the controller and the operation diagram is as following.

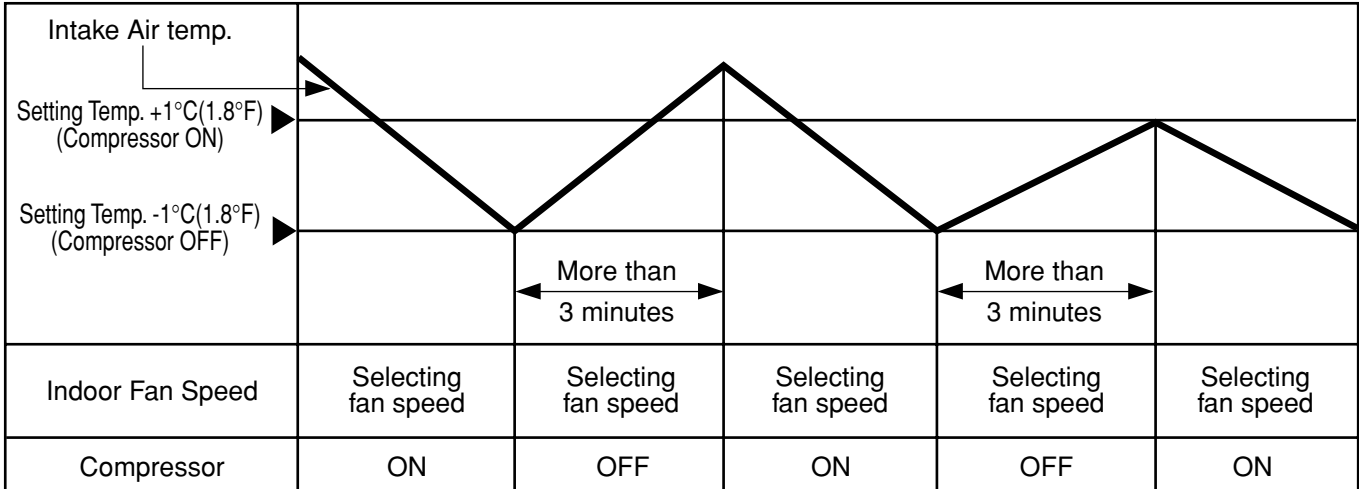

## 4. Off Timer Function

This function is to set the time of stopping the unit operation.

The procedure is as the following.

**1st:** Press the timer set button on the Remocon.

**2nd:** The buzzer sounds and then the display window shows the Off-Time to be set as 1 → ... → 7 → 0

- The Off-Time is shifted as the following by each press.

1 → 2 → 3 → 4 → 5 → 6 → 7 → 0

- If you select '0', the Off-Timer function will be cancelled.
- During Off-Timer Operation, if you repress the timer set button, the rest time will be displayed.

## 5. Heating Mode Operation

The unit will operate according to the setting by the remote controller and the operation diagram is shown as following.

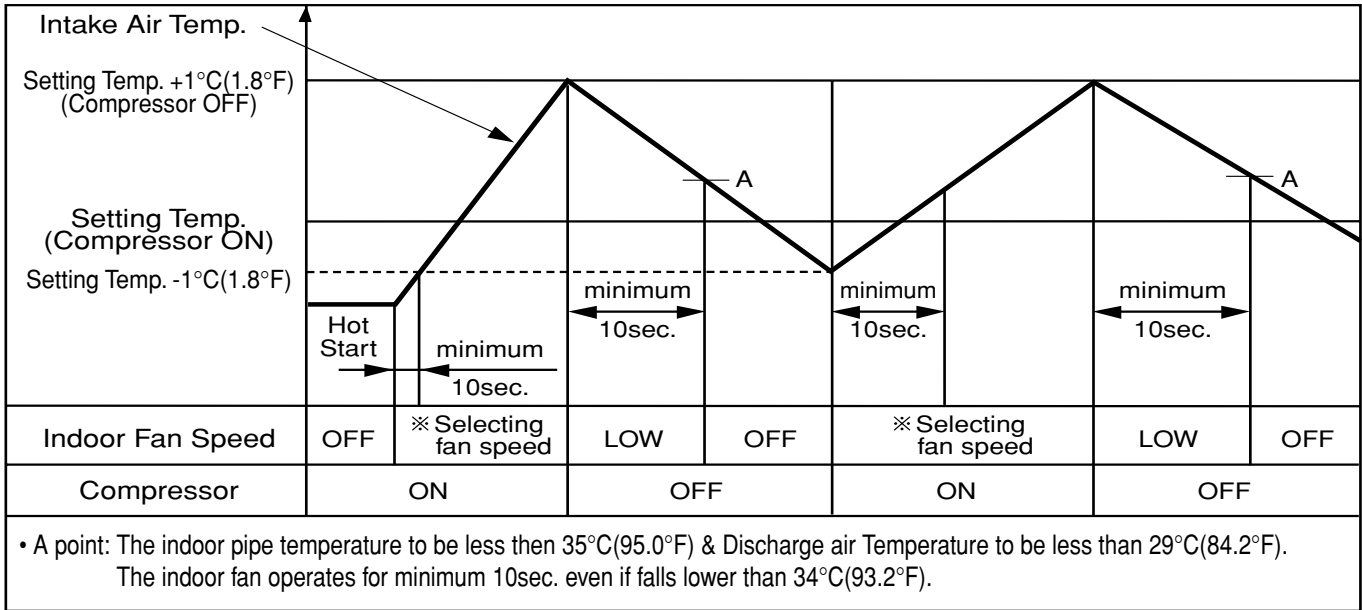

※ During heating operation, the operating procedure of the indoor fan is as the following.

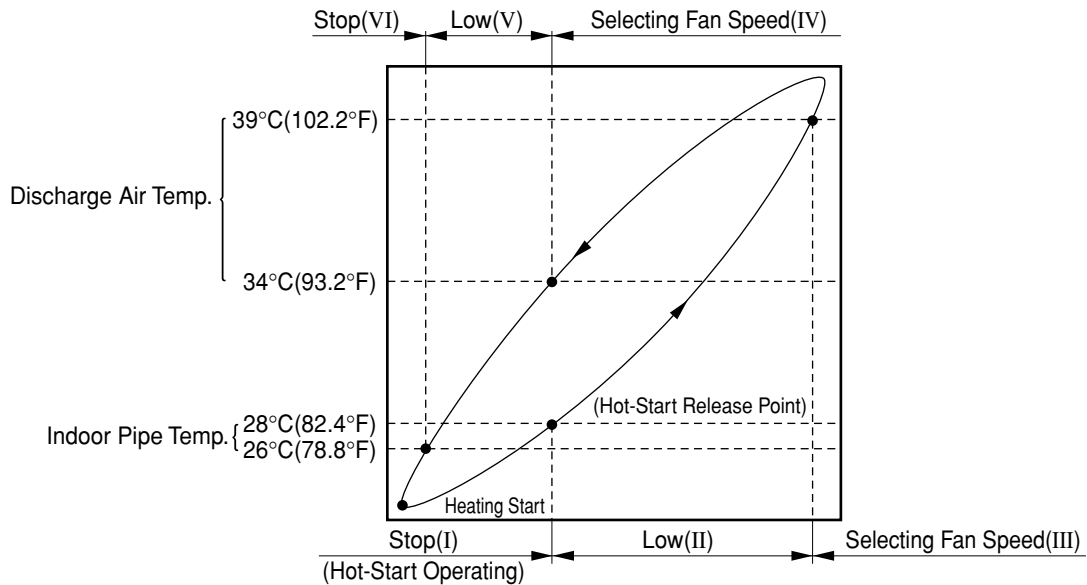

Step	Indoor fan speed	Pipe temp.	Air discharge temp.
I	Off	≤28°C(82.4°F)(Hot start operating)	-
II	Low	≥28°C(82.4°F)	< 39°C(102.2°F)
III	Selecting speed	≥28°C(82.4°F)	≥ 39°C(102.2°F)
IV	Selecting speed	≥28°C(82.4°F)	> 34°C(93.2°F)
V	Low	≥26°C(78.8°F)	≤ 34°C(93.2°F)
VI	Off	≤26°C(78.8°F)	-

## 6. Hot-Start Control

- The indoor fan stops until the evaporator piping temperature will be reached to 28°C(82.4°F).
- During heating operation, if piping temperatures fall below 26°C(78.8°F) fan stops.
- The operation diagram is as following.

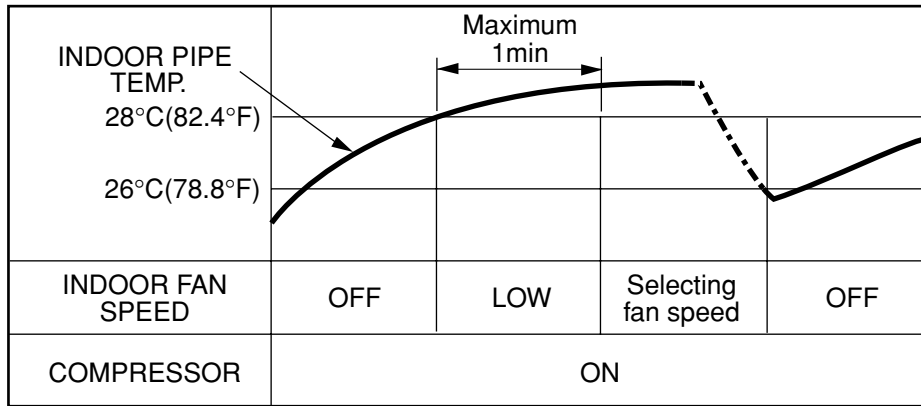

## 7. Defrost Control

- Defrost operation is controlled by timer and sensing temperature of outdoor pipe.
- The first defrost starts only when the outdoor pipe temperature falls below -6°C(21.2°F) after 45 minutes passed from starting of heating operation and more than.
- Defrost ends after 10 minutes pass from starting of defrost operation or when the outdoor pipe temperature rises over 12°C(53.6°F) even if before 10 minutes.
- The second defrost starts only when the outdoor pipe temperature falls below -6°C(21.2°F) after 45 minutes pass from ending of the first defrost and more than.

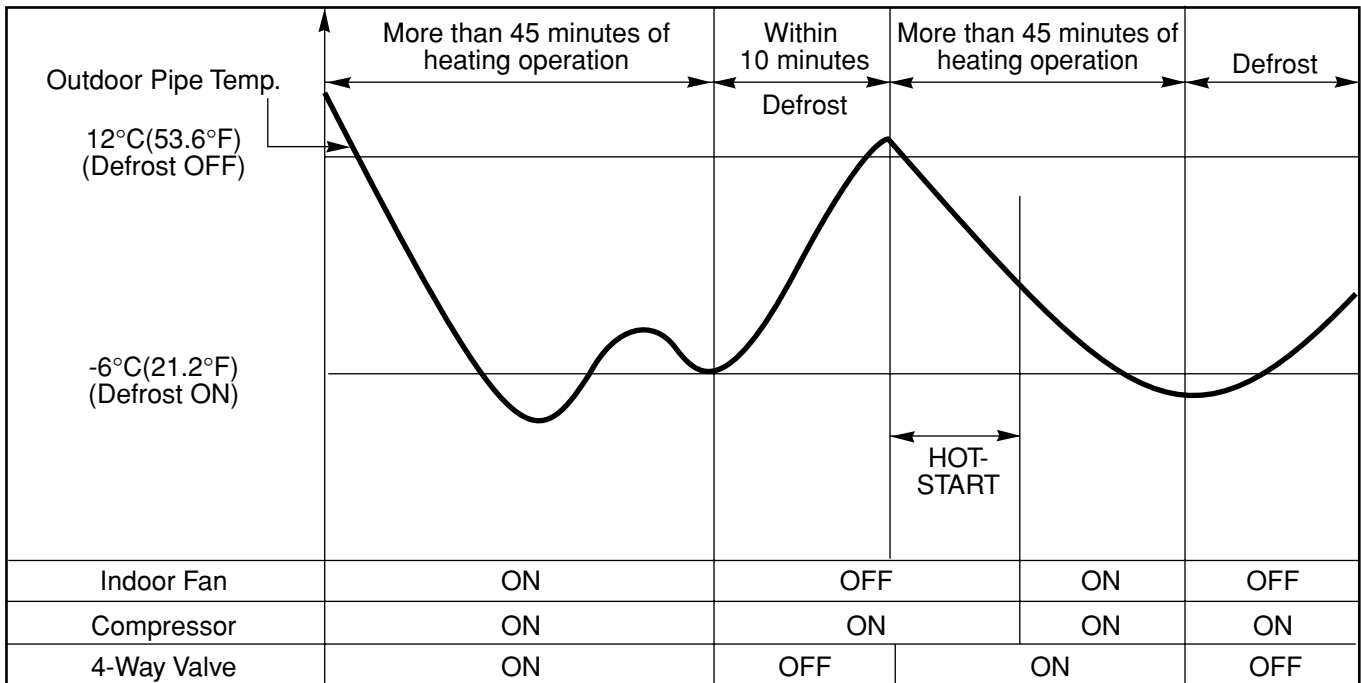

## 8. Soft Dry Operation Mode

- During Soft Dry Operation, the compressor ON temperature is the setting temperature plus 2°C(3.6°F), the compressor OFF temperature is the setting temperature minus 1°C(1.8°F).
- When the room temperature rises over the compressor ON temperature, the operation mode is switched to the Cooling mode.
- When the room temperature falls between the compressor ON temperature and OFF temperature, the operation mode is switched to the Soft Dry Operation.
- The operation diagram is shown below.

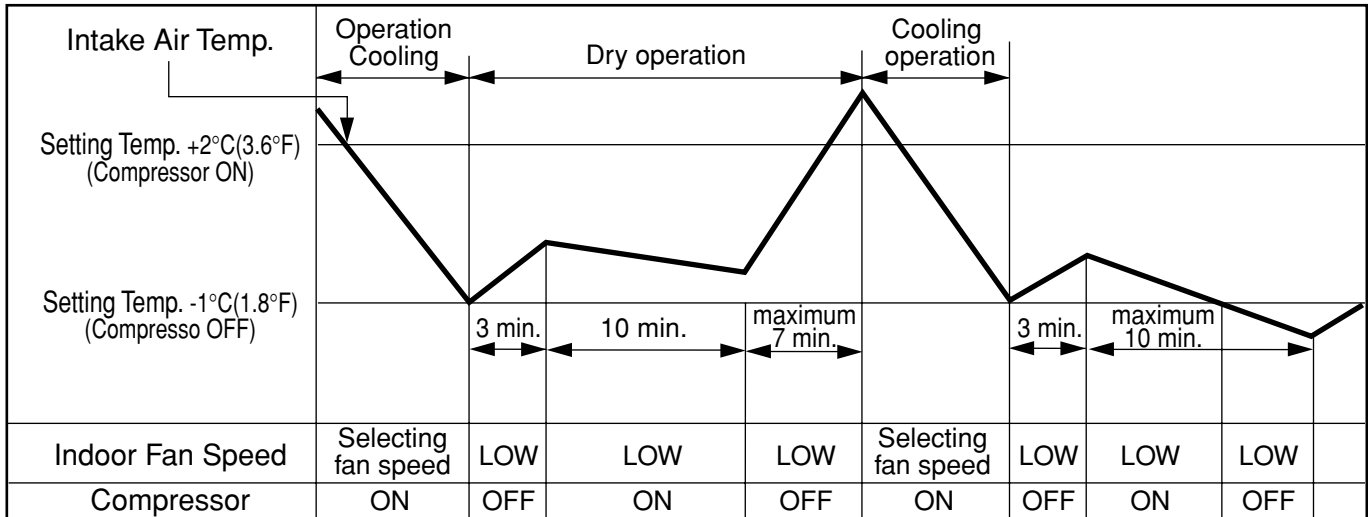

## 9. Protection of the evaporator pipe from frosting

- Compressor and outdoor fan stop when indoor pipe temperature is below -2°C(28.4°F) and restart at the pipe temperature is above 12°C(53.6°F).

## 10. Air Purifying Operation(AP-Z286RC0, AP-Z286R20, AP-Z488TC0)

Mode Selecting	Operating Mode	Fan Speed	Outdoor	OFF
Initial Starting of Air purifying Operation	- Outdoor not operating - Fan operating + Air purifying operating	- Low at the initial - But could be switched to Med. Hi	OFF	Repress Air purifying Button or ON/OFF Button
When switched to Air purifying operation	- Outdoor operating - Main Operating + Air purifying operating	Selecting Speed of Main Operating Mode	ON or OFF depend on main operating condition.	

## 11. Child Lock function

This function is to operate Air conditioner only by Remocon.

The procedure is as the following

**1st:** Press the 2 buttons of the temperature control simultaneously, to raise-to lower on the Display Panel of the product for more 3 seconds.

**2nd:** The buzzer sounds and then the window of Display Panel shows  $\overline{CL}$  (CL) mark.

**3rd:** To release this function, the reverse again the operating procedure could be done.

\* During this function is operating, any buttons of Display Panel don't work. But it is possible to operate with Remote controller.

## 12. Alarm mode display / only displayed while operating.

⌈ 0 : The sensor for sensing room temperature is open or short.

⌈ 1 : The sensor for sensing piping temperature is open or short.

## 13. Energy Saving

- ① If setting temperature of starting energy saving operation is under 22°C(71.6°F), first, setting temperature it up to 22°C(71.6°F) and perform energy saving operation.
- ② After energy saving operation starts, if adaptation time of the human body pass from the point which room temperature and setting temperature meet together, increase setting temperature 1°C(1.8°F) more.
- ③ If it doesn't satisfy number ① even in 50 minutes from the start of energy saving operation, increase 1°C(1.8°F).
- ④ After increasing setting temperature 1°C(1.8°F) more by number ①, ②, perform number ②, ③ again, if setting temperature goes up to 25°C(77.0°F), maintain this temperature.
- ⑤ If setting temperature goes down to under 25°C(77.0°F), during the operation, do number ②, ③, ④ again.

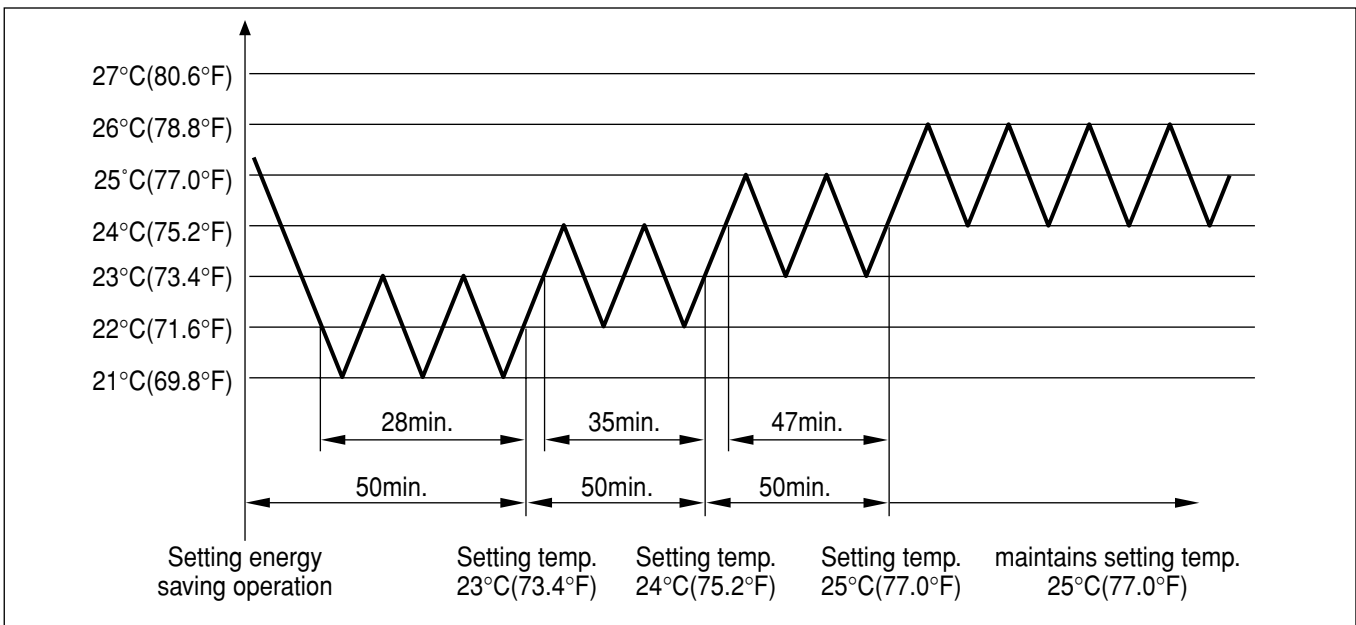

## 14. AUTO RESTART

In case the power comes on again after a power failure, Auto Restarting Operation is the function to operate procedures automatically to the previous operating conditions.

## 15. Function of changing set temperature when re-operation after stop.

Operation is set the following condition when re-operation with start/stop button.

1. Operation mode.

Cooling/soft dry mode → Cooling mode

Heating mode → Heating mode

2. Setting the set temperature when cooling operation.

Room temperature > Set temperature: to be set to the previous set temperature.

Room temperature ≤ Set temperature

a) Room temperature ≥ 26°C(78.8°F): to be set to 24°C(75.2°F)

b) 22°C(71.6°F) ≤ Room temperature ≤ 25°C(77.0°F): to be set to 21°C(69.8°F)

c) 19°C(66.2°F) ≤ Room temperature ≤ 21°C(69.8°F): to be set to -1°C(1.8°F) less than room temperature.

d) Room temperature ≤ 18°C(64.4°F): to be set to 18°C(64.4°F)

3. Setting the set temperature when heating operation.

Room temperature < Set temperature: to be set to the previous set temperature.

Room temperature  $\geq$  Set temperature

a) Room temperature  $\leq 20^{\circ}\text{C}(68.0^{\circ}\text{F})$ : to be set to  $23^{\circ}\text{C}(73.4^{\circ}\text{F})$

b)  $21^{\circ}\text{C}(69.8^{\circ}\text{F}) \leq$  Room temperature  $\leq 25^{\circ}\text{C}(77.0^{\circ}\text{F})$ : to be set to  $26^{\circ}\text{C}(78.8^{\circ}\text{F})$

c)  $26^{\circ}\text{C}(78.8^{\circ}\text{F}) \leq$  Room temperature  $\leq 28^{\circ}\text{C}$ : to be set to  $+1^{\circ}\text{C}$  more than room temperature.

d)  $29^{\circ}\text{C}(84.2^{\circ}\text{F}) \leq$  Room temperature : to be set to  $30^{\circ}\text{C}(86.0^{\circ}\text{F})$

## 16. Function for test operation

### 1) Outline of Operation

- This is for checking the condition of installation during the installation, and it is operated by cooling, Fan speed is high, comp. on, and Auto air flow operations without setting temperature.

### 2) Operation or Cancel

- Do test operation, if you push ON/OFF button and the down room temperature checking button over 3 seconds at the same time.

- During the operation, if you push the stop button or push ON/OFF button and the down room temperature checking button over 3 seconds at the same time, the test operation will be cancelled and unit come to rest.

- During the operation, if you input remote key or key on Display panel, it performs its duties.

### 3) Function

- It operates cooling, fan speed is high, auto air flow operation, comp. on for  $18 \pm 1$  minutes, regardless of room temperature.

- After  $18 \pm 1$  minutes of operation, it becomes off itself.

- During the operation, signal *BB* stands for "Lo"

# Installation of Indoor, Outdoor Unit

## 1. Selection of the best location

### 1) Indoor unit

- There should not be any heat source or steam near the unit.
- There should not be any obstacles to prevent the air circulation.
- A place where air circulation in the room will be good.
- A place where drainage can be easily obtained.
- A place where noise prevention is taken into consideration.
- Do not install the unit near the door way.
- Ensure the spaces indicated by arrows from the wall, ceiling, fence, or other obstacles.

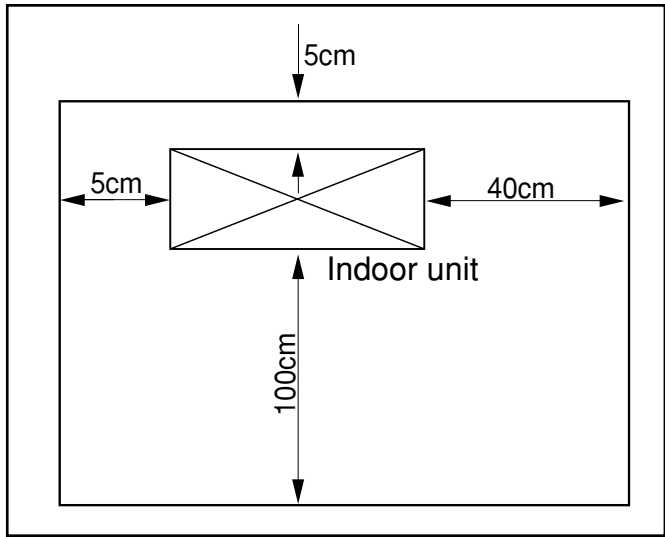

### 2) Outdoor unit

- If an awning is built over the unit to prevent direct sunlight or rain exposure, be careful that heat radiation from the condenser is not restricted.
- There should not be any animals or plants which could be affected by discharged hot air.
- Ensure the space indicated by arrows from the wall, ceiling, fence, or other obstacles.

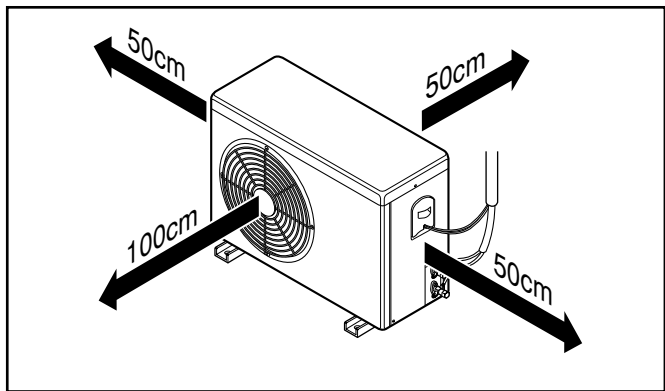

### 3) Piping length and the elevation

#### Cooling Only Model

MODEL	PIPE SIZE		Max. Length A (m)	Max. Elevation B (m)
	GAS SIDE	LIQUID SIDE		
48K	3/4"	3/8"	30	20
30K	5/8"	3/8"	30	20

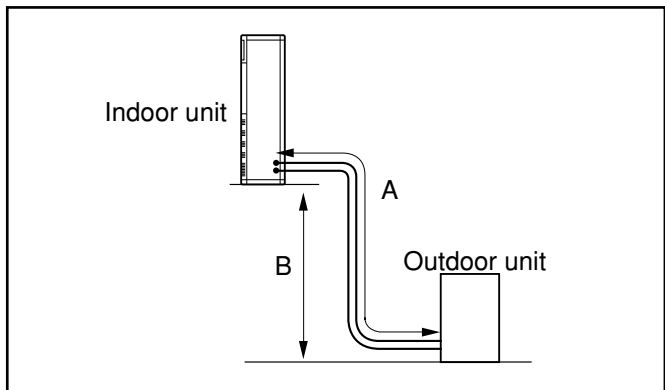

## 2. Indoor Unit installation

- ① The mounting floor should be strong and solid enough to prevent it from vibration.
- ② Drill the piping hole with 70mm diameter hole-core drill at either the right or the left of indoor unit. The hole should be slightly slant to the outdoor side.

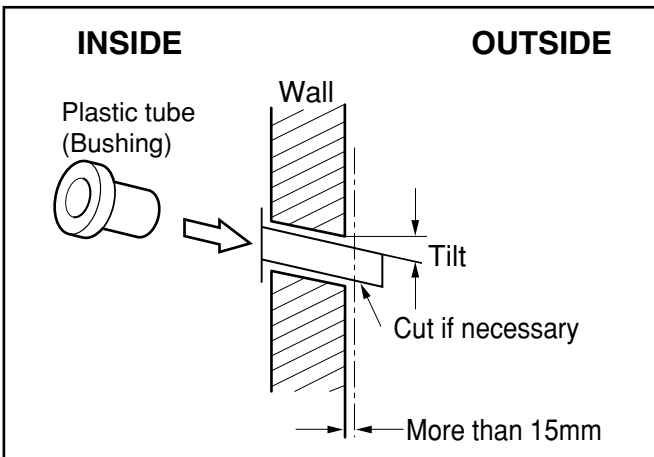
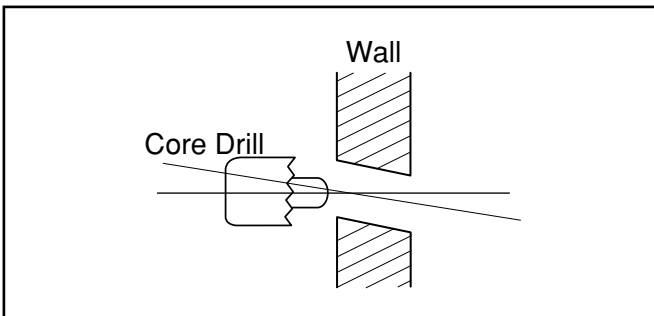
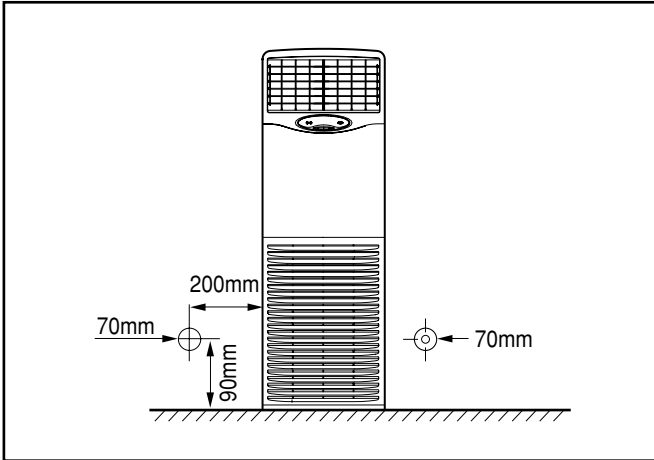

- ③ Insert the plastic tube through the hole.
- ④ Cut the extruded outside part of the plastic tube, if necessary.

## 3. Outdoor unit Installation

- ① Install the outdoor unit on the concrete or any solid base securely and horizontally by securing it with bolts (Ø12mm) and nuts.
- ② If there is any vibration transmitted to the building, mount the rubber underneath the outdoor unit.

## 4. Refrigerant amount

Before shipment, this air conditioner is filled with the rated amount of refrigerant including additional amount required for air-purging, subject to 5m piping length. (The rated amount of refrigerant is indicated on the name plate.) But when the piping length exceeds 5 meters, additional charge is required according to the following table.

MODEL	REFRIGERANT CHARGE
48K	40g per 1m
30K	30g per 1m

Example)

In case of 10m long pipe(one-way), the amount of refrigerant to be replenished is:

$$(10 - 5) \times 30 = 150g$$

# Test running

---

## 1. PRECAUTIONS IN TEST RUN

- The initial power supply must provide at least 90% of the rated voltage. Otherwise, the air conditioner should not be operated.

**Caution**

Carry out the test run more than 5 minutes without fail.  
(Test run will be cancelled 18 minutes later automatically)

- The test run is started by pressing the down room temperature checking button and ON/OFF button for 3 seconds at the same time.
- To cancel the test run, press ON/OFF button.

### CHECK THE FOLLOWING ITEMS WHEN INSTALLATION IS COMPLETE

- After completing work, be sure to measure and record trial run properties, and store measured data, etc.
- Measuring items are room temperature, outside temperature, suction temperature, blow out temperature, wind velocity, wind volume, voltage, current, presence of abnormal vibration and noise, operating pressure, piping temperature, compressive pressure.
- As to the structure and appearance, check following items.

- Is the circulation of air adequate?
- Is the draining smooth?
- Is the heat insulation complete (refrigerant and drain piping)?
- Is there any leakage of refrigerant?

- Is the remote controller switch operated?
- Is there any faulty wiring?
- Are not terminal screws loosened?

M4...118N·cm{12kgf·cm}    M5...196N·cm{20kgf·cm}  
M6...245N·cm{25kgf·cm}    M8...588N·cm{60kgf·cm}

## 2. Connection of power supply

1. Connect the power supply cord to the independent power supply.
  - Circuit breaker is required.
2. Operate the unit for fifteen minutes or more.

## 3. Evaluation of the performance

1. Measure the temperature of the intake and discharge air.
2. Ensure the difference between the intake temperature and the discharge one is more than 8°C(46.4°F) (Cooling) or reversely (Heating).

## CAUTION

After the confirmation of the above conditions, prepare the wiring as follows:

- 1) **Never fail to have an individual power specialized for the air conditioner. As for the method of wiring, be guided by the circuit diagram pasted on the inside of control box cover.**
- 2) **Provide a circuit breaker switch between power source and the unit.**
- 3) **The screw which fasten the wiring in the casing of electrical fittings are liable to come loose from vibrations to which the unit is subjected during the course of transportation. Check them and make sure that they are all tightly fastened. (If they are loose, it could give rise to burn-out of the wires.)**
- 4) **Specification of power source**
- 5) **Confirm that electrical capacity is sufficient.**
- 6) **Be sure that the starting voltage is maintained at more than 90 percent of the rated voltage marked on the name plate.**
- 7) **Confirm that the cable thickness is as specified in the power sources specification. (Particularly note the relation between cable length and thickness.)**
- 8) **Never fail to equip a leakage breaker where it is wet or moist.**
- 9) **The following troubles would be caused by voltage drop-down.**
  - Vibration of a magnetic switch, damage on the contact point there of, fuse breaking, disturbance to the normal function of a overload protection device.
  - Proper starting power is not given to the compressor.

## HAND OVER

Teach the customer the operation and maintenance procedures, using the operation manual (air filter cleaning, temperature control, etc.).

If Error Code happens in the display of indoor.

Error Code	Error Contents	Checking Point
C0	Indoor Air Sensor Open or Short	1.Check Sensor Connection to PCB whether it's connected well or not. 2.Replace it with new Sensor.
C1	Indoor Pipe Sensor Open or Short	
C3	Outdoor Air Sensor Open or Short	
C4	Outdoor Pipe Sensor Open or Short	
C5	Communication failure between Indoor and outdoor unit.	1.Check connecting cable wiring order between Indoor and outdoor diagram. 2.Check all wire connector whether it is connected or not. 3.Indoor AC PCB defects.(short inside). 4.Outdoor PCB defects.(short inside)

# Cycle Troubleshooting Guide

## Trouble analysis

1. Check temperature difference between intake and discharge air and operating current.

	Temp. difference : approx. 0°C(0°F) Current : less than 80% of rated current	All amount of refrigerant leaked out Check refrigeration cycle
Temp. Difference	Temp. difference : approx. 8°C(14.4°F) Current : less than 80% of rated current	Refrigerant leakage Clog of refrigeration cycle Defective compressor
Operating Current	Temp. difference : less than 8°C(14.4°F) Current : over the rated current	Excessive amount of refrigerant
	Temp. difference : over 8°C(14.4°F)	Normal

### Notice :

Temperature difference between intake and discharge air depends on room air humidity. When the room air humidity is relatively higher, temperature difference is smaller. When the room air humidity is relatively lower temperature difference is larger.

2. Check temperature and pressure of refrigeration cycle.

Suction pressure (Compared with the normal value)	Temperature (Compared with the normal value)	Cause of Trouble	Description
Higher	High	Defective compressor Defective 4-way reverse valve	Current is low
	Normal	Excessive amount of refrigerant	High pressure does not quickly rise at the beginning of operation
Lower	Higher	Insufficient amount of refrigerant (Leakage) Clogging	Current is low Current is low

### Notice :

- The suction pressure is usually 4.5~6.0 kg/cm<sup>2</sup>G at normal condition.
- The temperature can be measured by attaching the thermometer to the low pressure tubing and wrap it with putty.

# Electronic Parts Troubleshooting Guide

## 1) No Cooling operation performed

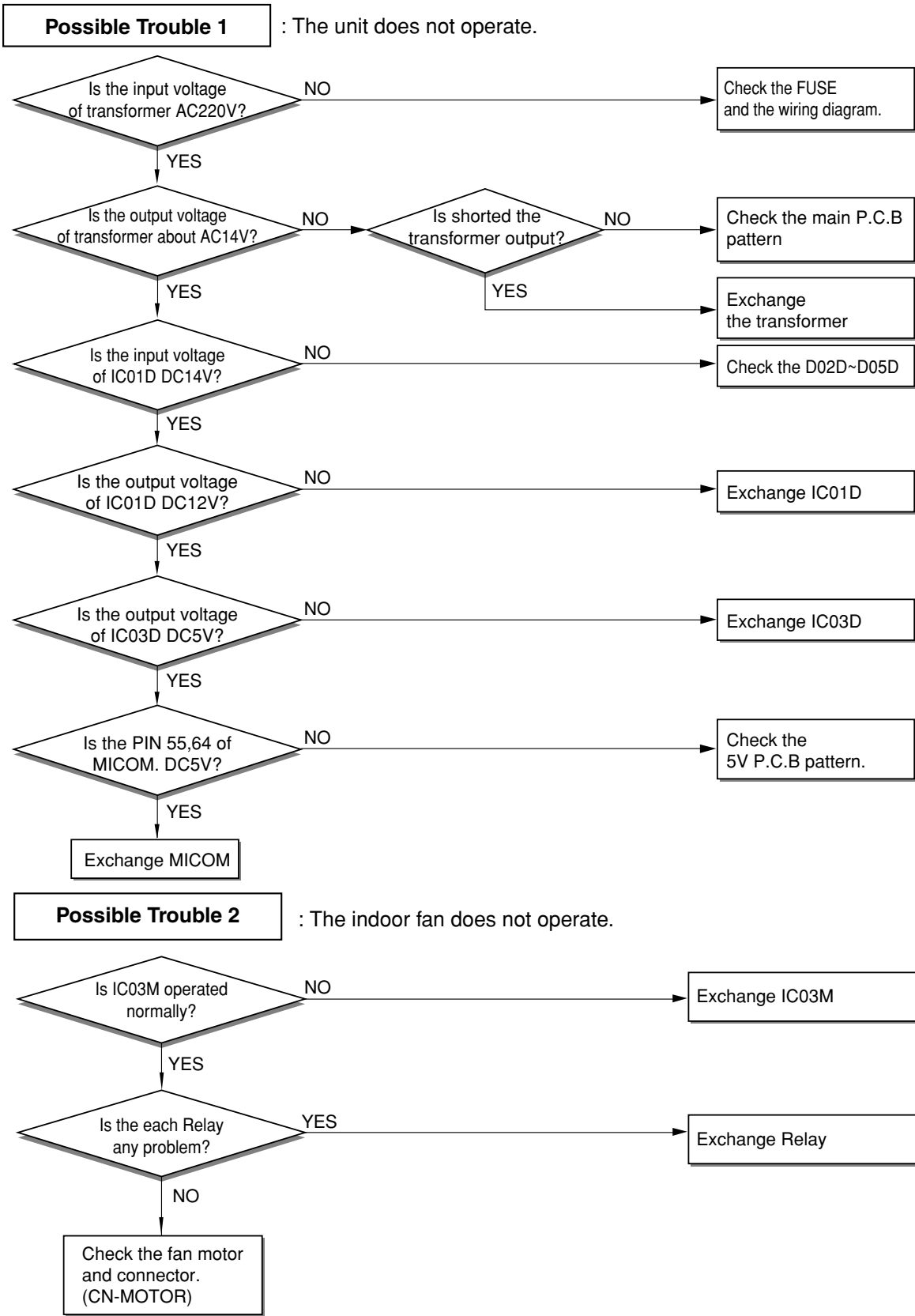

# Exploded View and Replacement Parts List

## 1. Indoor Unit

• Model : LF300CP(LP-C303R20)

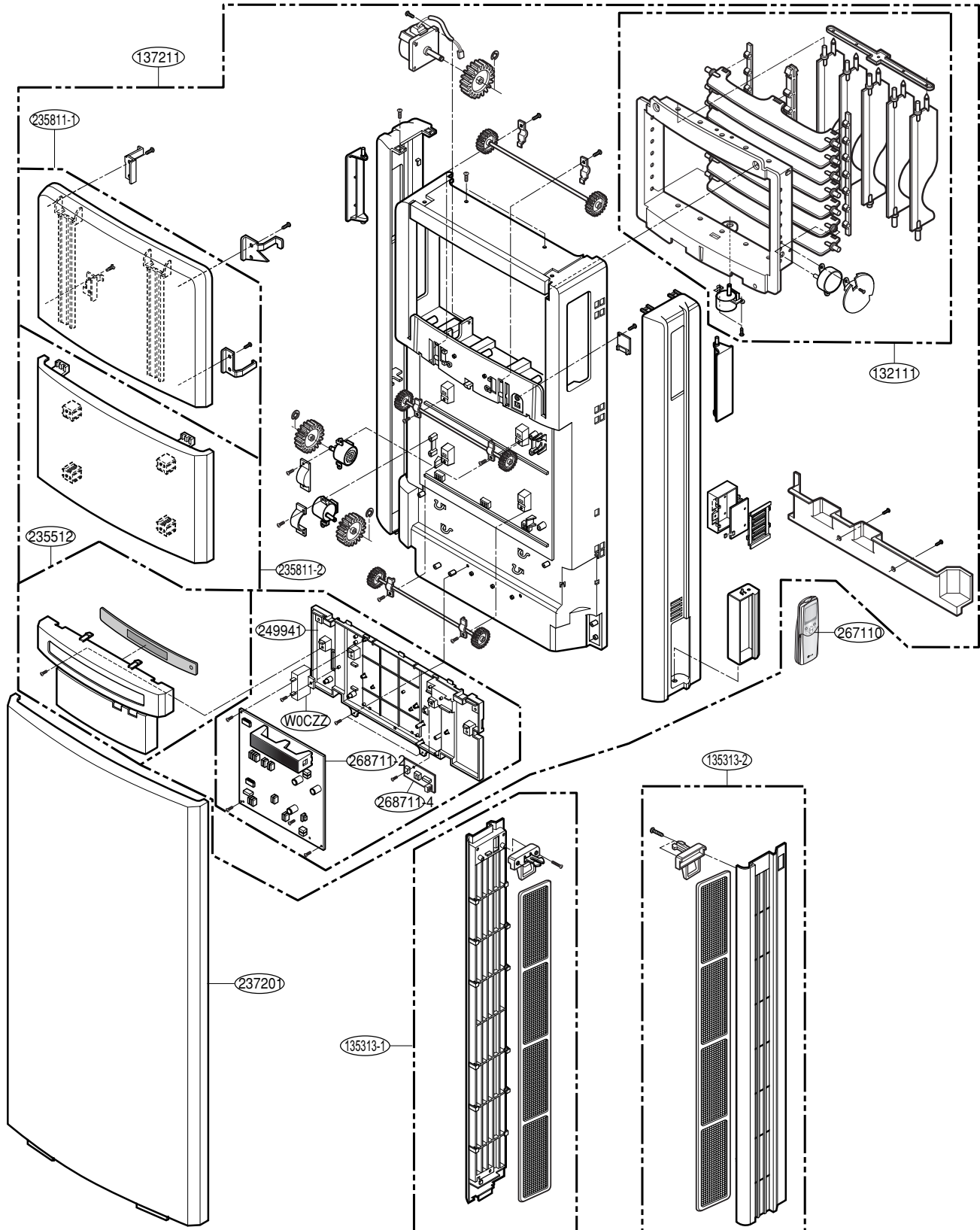

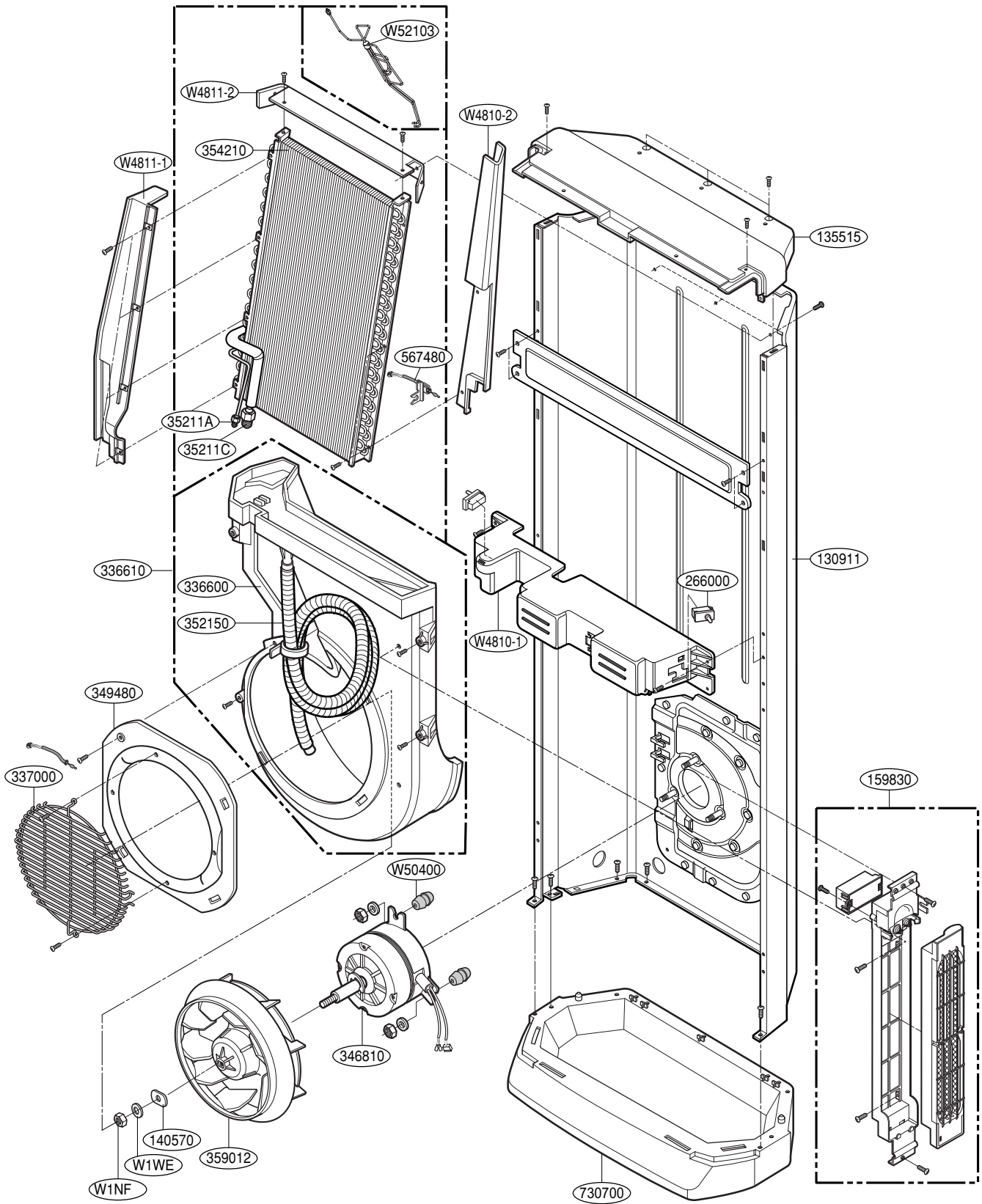

## Parts List (Indoor Unit )

LOCATION No.	DESCRIPTION	PART No.	Remark
		LF300CP	
130911	CABINET ASSEMBLY,INDOOR	3091A10037V	R
132111	FRAME ASSEMBLY	3210A20046A	R
137211	PANEL ASSEMBLY,FRONT(INDOOR)	3721A10130R	R
140570	LOCKER ASSEMBLY	4A01405C	R
159830	AIR CLEANER ASSEMBLY	5983A10004L	R
235512	COVER ASSEMBLY,DISPLAY	3551A20135N	R
237201	PANEL, BASE	3720A10105H	R
249941	CONTROL BOX,INDOOR	4994A10042B	R
266000	SWITCH,PUSH	6600AP2059A	R
267110	REMOTE CONTROLLER ASSEMBLY	6711A20060F	R
268711-2	PWB(PCB) ASSEMBLY,MAIN(AC)	6871A10136T	R
567480	THERMISTOR ASSEMBLY	6323A20016A	R
336600	HOUSING (MECH),WRAPPER	3660A20023L	R
336610	HOUSING ASSEMBLY(MECH)	3661A20017M	R
337000	NET,STEEL	3700A30001A	R
346810	MOTOR ASSEMBLY,INDOOR	4681A20180A	R
349480	ORIFICE	4948A20008A	R
352150	HOSE ASSEMBLY,DRAIN	5251AR1222N	R
354210	EVAPORATOR ASSEMBLY,FIRST	5421A20039P	R
359012	FAN ASSEMBLY,TURBO	5901A20021B	R
135515	COVER ASSEMBLY, TOP(INDOOR)	3551A10022A	R
268711-4	PWB(PCB) ASSEMBLY,SUB	6871AQ3212D	R
730700	BASE,INSTALL	3040A20067B	R
135313-1	GRILLE ASSEMBLY,INLET	3531A10203R	R
135313-2	GRILLE ASSEMBLY,INLET	3531A10203S	R
235811-1	DOOR ASSEMBLY,CLEAN	3581A20005V	R
235811-2	DOOR ASSEMBLY,CLEAN	3581A20006M	R
35211A	TUBE ASSEMBLY,SUCTION INDOOR	5211A20851B	R
35211C	TUBE ASSY,DISCHARGE (INDOOR)	5211A20854A	R
W0CZZ	CAPACITOR,DRAWING	3H00660N	R
W1NF	NUT,HEXAGON	1NHA0801206	R
W1WE	WASHER,SPRING LOCK	1WSD0800030	R
W4810-1	BRACKET	4810A20142A	R
W4810-2	BRACKET	4810A10008A	R
W4811-1	BRACKET ASSEMBLY	4811A30011B	R
W4811-2	BRACKET ASSEMBLY	4811A30021A	R
W50400	RUBBER	5040A30031A	R
W52103	TUBE,DISTRIBUTOR	2H00351D	R

• Model : LF480CE(LP-C483TA0)

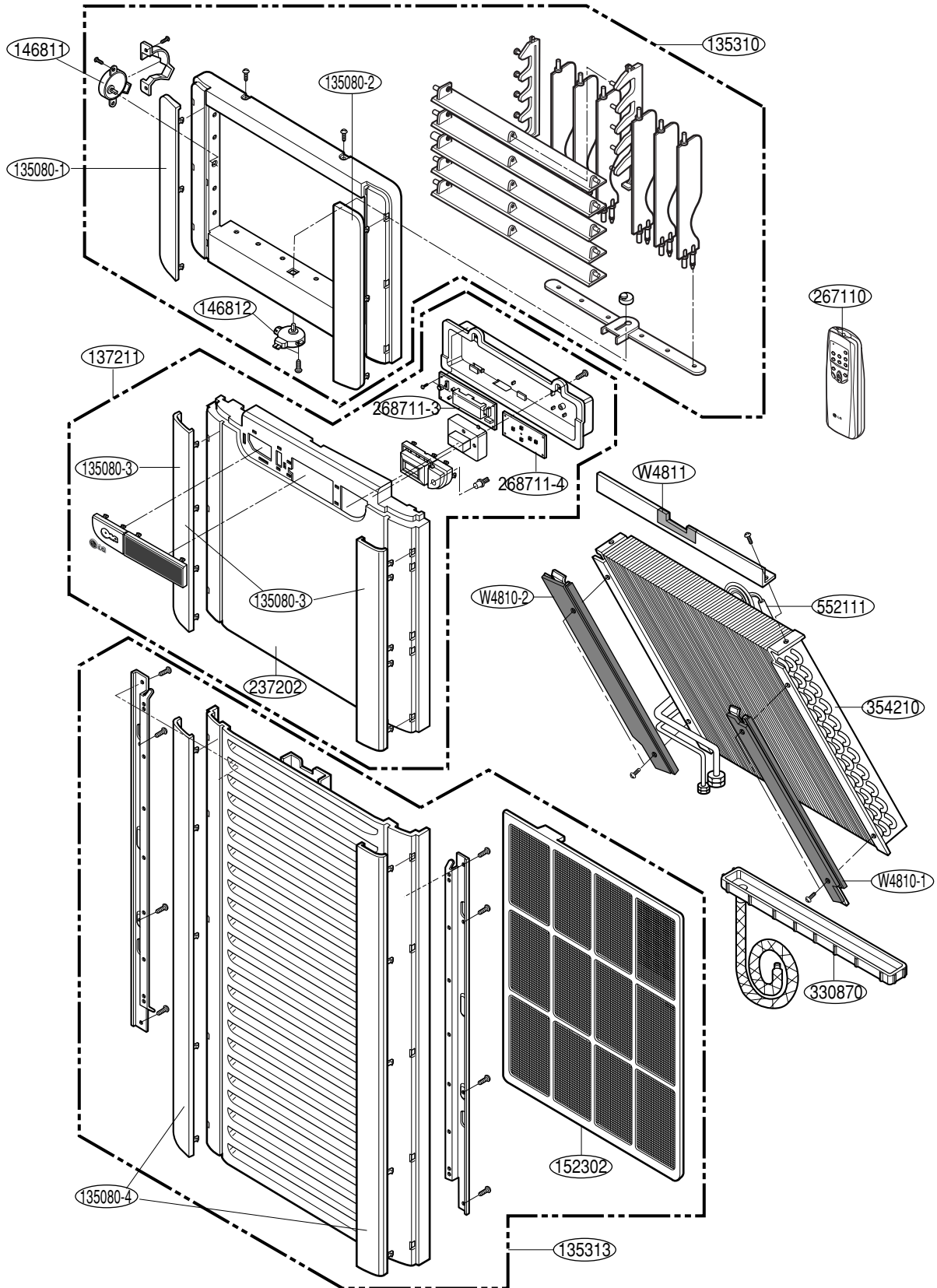

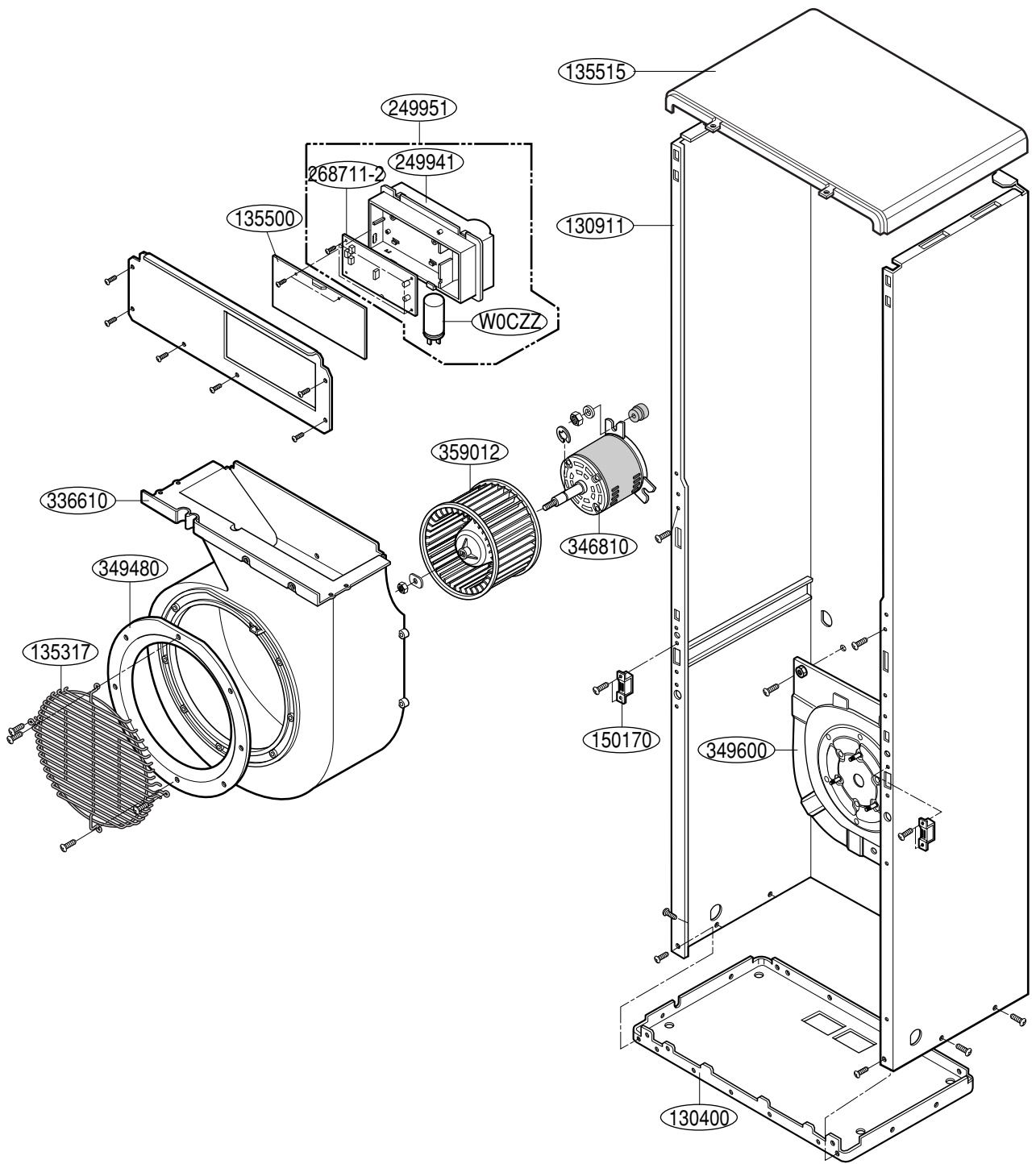

## Parts List (Indoor Unit )

LOCATION No.	DESCRIPTION	PART No.	Remark
		LF480CE(LP-C483TA0)	
130400	BASE,INDOOR	3040AP2199D	R
135080-1	DECORATION	3508A20025E	R
135080-2	DECORATION	3508A20025F	R
135080-3	DECORATION	3508A20026C	R
130911	CABINET ASSEMBLY,INDOOR	3091A10058D	R
135310	GRILLE ASSEMBLY,DIFFUSER(INDOOR)	3531A20099C	R
135313	GRILLE ASSEMBLY,INLET	3531A10126D	R
135500	COVER	3550A10039C	R
135515	COVER ASSEMBLY,TOP(INDOOR)	3551A10013C	R
137211	PANEL ASSEMBLY,FRONT(INDOOR)	3721A10157D	R
146811	MOTOR ASSEMBLY,STEP	4681AP2968C	R
146812	MOTOR ASSEMBLY,SYNC.	2H01102A	R
150170	MAGNET ASSEMBLY,MECH	3A02221A	R
152302	FILTER(MECH),A/C	5230A20015A	R
237202	PANEL,FRONT	3720A10055C	R
249941	CONTROL BOX,INDOOR	4994A10026D	R
249951	CONTROL BOX ASSEMBLY,INDOOR	4995A20200Y	R
267110	REMOTE CONTROLLER ASSEMBLY	6711A20060G	R
268711-3	PWB(PCB) ASSEMBLY,MAIN	6871A10054Z	R
268711-2	PWB(PCB) ASSEMBLY,MAIN(AC)	6871A20183J	R
330870	DRAIN PAN ASSEMBLY	3087A30001E	R
336610	HOUSING ASSEMBLY(MECH)	3661A10022A	R
346810	MOTOR ASSEMBLY,INDOOR	4681A10025F	R
349480	ORIFICE	4948A20023A	R
349600	MOUNT,MOTOR	4960A20050A	R
354210	EVAPORATOR ASSEMBLY,FIRST	2A00971G	R
359012	FAN ASSEMBLY,BLOWER	5901A10039B	R
135317	GRILLE ASSEMBLY,INDOOR MOTOR	3531A20082B	R
552111	TUBE ASSEMBLY,CAPILLARY	5211A30413B	R
268711-4	PWB(PCB) ASSEMBLY,SUB	6871A20184A	R
W0CZZ	CAPACITOR,DRAWING	3H00660J	R
W4810-1	BRACKET	3A02093B	R
W4810-2	BRACKET	3A02094C	R
W4811	BRACKET ASSEMBLY	4811A30022A	R

## 2. Outdoor Unit

• Model : LF300CP(LP-C303R20)

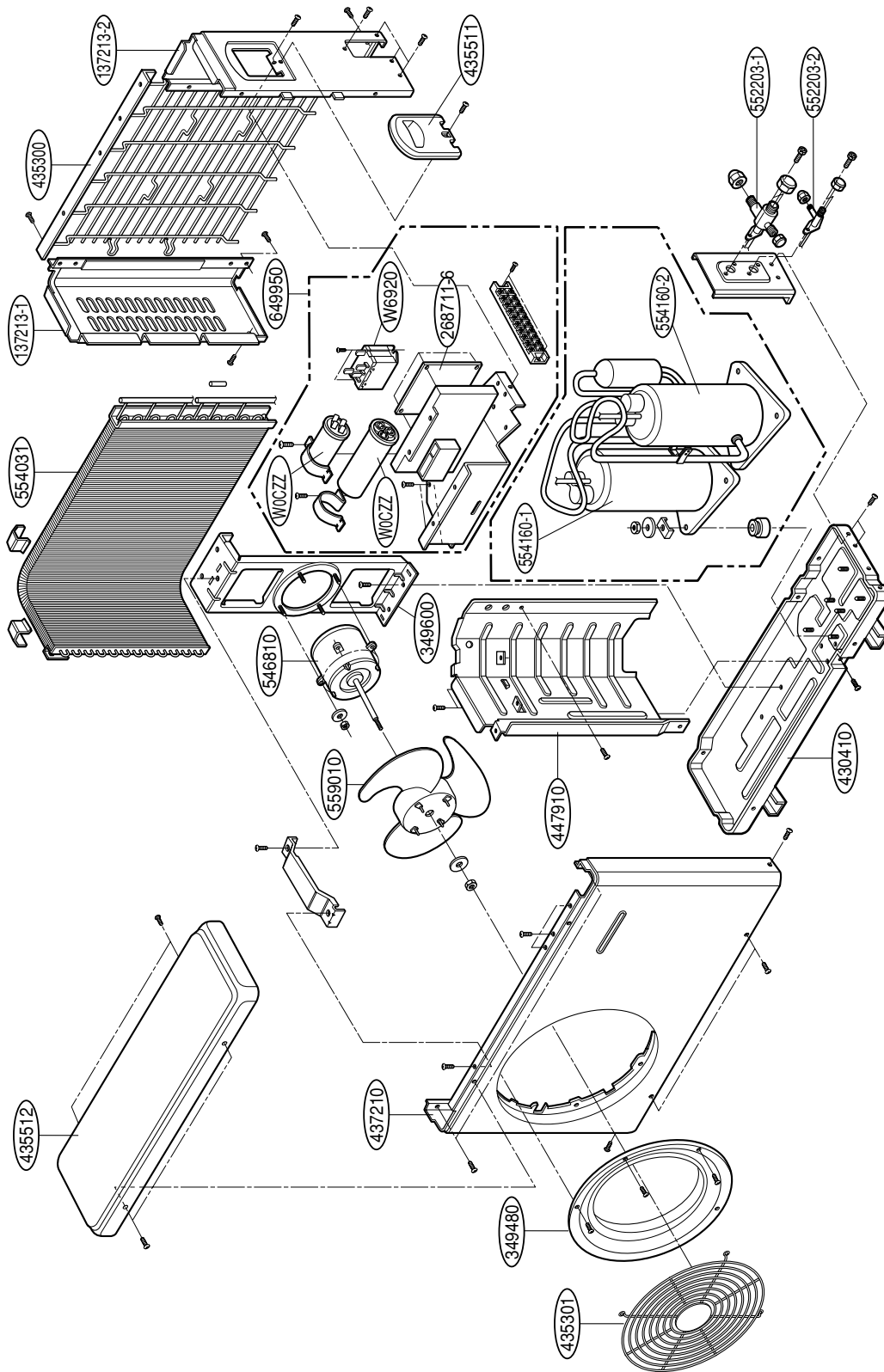

## Parts List (Outdoor Unit )

LOCATION No.	DESCRIPTION	PART No.	Remark
		LF300CP	
137213-1	PANEL ASSEMBLY,SIDE	1A00202F	R
137213-2	PANEL ASSEMBLY,SIDE	3A02284F	R
349480	ORIFICE	4948AP2527A	R
349600	MOUNT,MOTOR	1A00206B	R
430410	BASE ASSEMBLY,OUTDOOR	3041AP2741Q	R
435300	GRILLE,REAR	1A00208D	R
435301	GRILLE,DISCHARGE	3530A20007J	R
435511	COVER ASSEMBLY,CONTROL(OUTDOOR)	3550AR2886C	R
435512	COVER ASSEMBLY,TOP(OUTDOOR)	3H03266H	R
437210	PANEL ASSEMBLY,FRONT SUB	1A00197C	R
447910	BARRIER ASSEMBLY,OUTDOOR	4791A30004H	R
546810	MOTOR ASSEMBLY,OUTDOOR	4681A20181A	R
554031	CONDENSER ASSEMBLY,BENDING	5403A20022S	R
554160-1	COMPRESSOR SET	2520UMGK1BA	R
554160-2	COMPRESSOR SET	2520UKLK1AA	R
559010	FAN ASSEMBLY,PROPELLER	5901A10020A	R
649950	CONTROL BOX ASSEMBLY,OUTDOOR	4995A10181A	R
268711-6	PWB(PCB) ASSEMBLY,MAIN(OUTDOOR)	6871A20332F	R
552203-1	VALVE,SERVICE	2A00392L	R
552203-2	VALVE,SERVICE	2A00393A	R
W0CZZ	CAPACITOR,DRAWING	3A00988B	R
W0CZZ	CAPACITOR,DRAWING	6120AR2194F	R
W6920	RELAY	6920WRD015A	R
W6920	RELAY	6920WRD008A	R

• Model : LF480CE(LP-C483TA0)

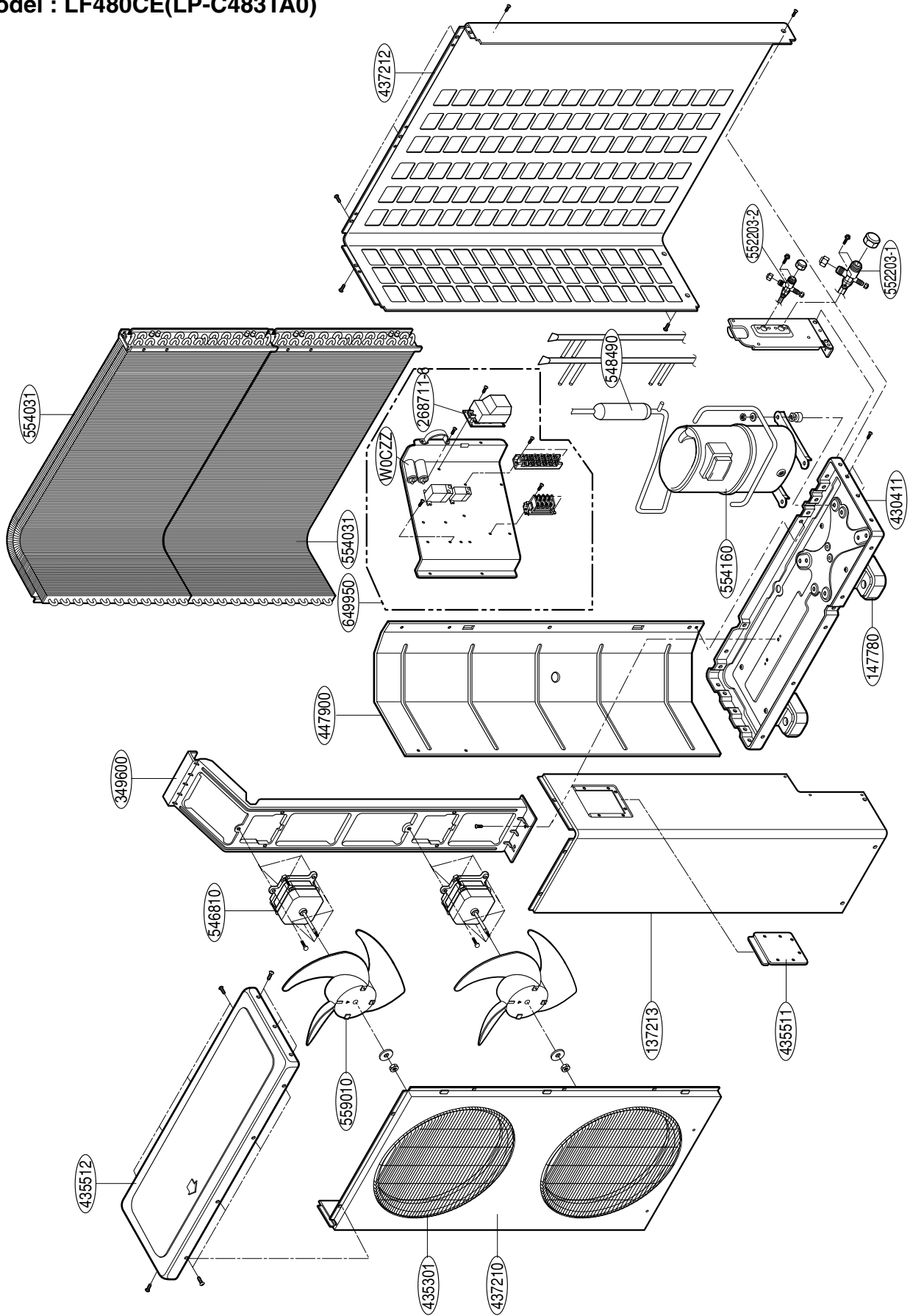

## Parts List (Outdoor Unit )

LOCATION No.	DESCRIPTION	PART No.	Remark
		LF480CE(LP-C483TA0)	
435301	GRILLE,DISCHARGE	3530AP1225D	R
137213	PANEL ASSEMBLY,SIDE	3721A20229A	R
147780	LEG	3A02521A	R
430411	BASE ASSEMBLY, WELD[OUTDOOR]	3041A20047F	R
435511	COVER ASSEMBLY,CONTROL(OUTDOOR)	3A01293X	R
435512	COVER ASSEMBLY,TOP(OUTDOOR)	3550AP1213B	R
437210	PANEL ASSEMBLY,FRONT SUB	3720AP1212B	R
437212	PANEL ASSEMBLY,REAR	3720AP1202L	R
447900	BARRIER,OUTDOOR	4760AP1216C	R
546810	MOTOR ASSEMBLY,OUTDOOR	4681A10030C	R
548490	ACCUMULATOR ASSEMBLY(MECH)	4849A20020H	R
349600	MOUNT,MOTOR	4960A10004A	R
554031	CONDENSER ASSEMBLY,BENT	5403A20124B	R
554160	COMPRESSOR SET	2520UHCK1BA	R
559010	FAN ASSEMBLY,PROPELLER	1A00195B	R
649950	CONTROL BOX ASSEMBLY,OUTDOOR	4995AG2098Z	R
268711-6	PWB(PCB) ASSEMBLY,MAIN(OUTDOOR)	6871A20332Z	R
552203-1	VALVE,SERVICE	2A00393P	R
552203-2	VALVE,SERVICE	2A00499A	R
W0CZZ	CAPACITOR,DRAWING	6120AR2194P	R

