



Single System Troubleshooting Charts

Dealer Site



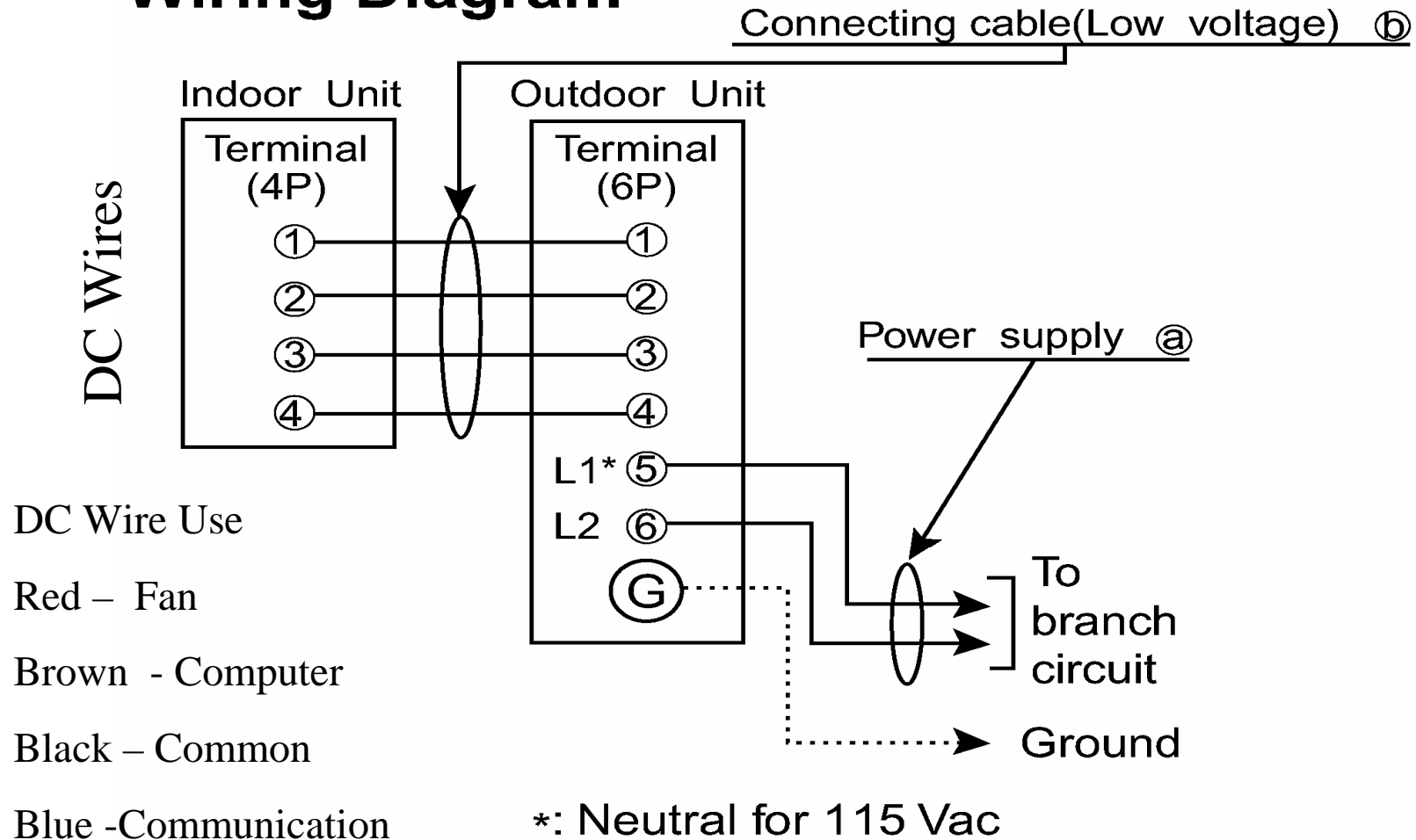

- 24/7 access for manuals, service information, catalogues
- <http://lgdealers.lg.ca>
- Account number: b2bac
- Password: b2bac05

Indoor to Outdoor Wiring – Single System

Wiring Diagram

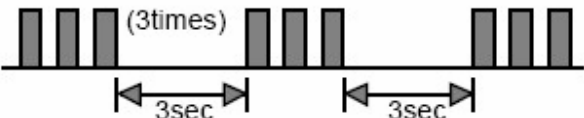

Self Diagnostic Chart Conventional Ductless

Error Code	Error LED (Indoor body operation LED)	Error contents	SVC check point
1		<ul style="list-style-type: none"> Indoor suction temperature thermistor open/short. Indoor pipe temperature thermistor open/short. 	<ul style="list-style-type: none"> Indoor TH ass'y check
2		<ul style="list-style-type: none"> Outdoor suction temperature thermistor open/short. Outdoor pipe temperature thermistor open/short. 	<ul style="list-style-type: none"> Outdoor TH ass'y check
3		<ul style="list-style-type: none"> Abnormal operation of multi product. (Simultaneous operation of cooling and heating) 	<ul style="list-style-type: none"> Resetting of remoon operating mode
5		<ul style="list-style-type: none"> Poor communication 	<ul style="list-style-type: none"> Communication line/circuit check
8		<ul style="list-style-type: none"> Indoor fan lock 	<ul style="list-style-type: none"> Check indoor fan motor and outdoor PCB ass'y

All conventional LS series single zone ductless

Applied Error Codes – 1,2,5 and 8

All conventional LM series dual zone and 36K triple zone ductless

Applied Error Codes – 1,2,3,5 and 8

Voltage Value Chart

Typical Pillar Block

LG/ VOLTAGE TESTS FOR INDOOR/OUTDOOR BOARDS

Pillar-Block Typical Voltages

BOARD	PIN NUMBERS TEST FROM		9 K DC VOLTS +/- 10%					12 K DC VOLTS +/- 10%				
			Turbo	HI	MED	LOW	OFF	Turbo	HI	MED	LOW	OFF
PILLAR	4	3	0 TO 12					0 TO 12				
TERMINAL	2	3	17					17				
VOLTAGE	1	3	28.6	25.6	22.2	20	0	37.7	30.7	25.1	21.2	0

	PIN NUMBERS TEST FROM		18 K DC VOLTS +/- 10%					24 K DC VOLTS +/- 10%				
			Turbo	HI	MED	LOW	OFF	Turbo	HI	MED	LOW	OFF
PILLAR	4	3	0 TO 12					0 TO 12				
TERMINAL	2	3	17					17				
VOLTAGE	1	3	32	27.8	24.1	21.2	0	35.7	33.3	29.4	24.2	0

NOTES : ALL WAYS CHECK DC/VOLTAGES AT THE PLUGS DIRECTLY AT BOARDS NOT AT PLUG CONNECTIONS
 PIN NUMBER #3 (Black Wire) IS ALWAYS GROUND
 OUTDOOR BOARD PINS 1 TO 3 ARE COMPRESSOR VOLTAGES

Voltage Value Chart

Typical Pillar Block

Indoor Fan Motor Typical Voltages

BOARD	PIN NUMBERS TEST FROM		9 K DC VOLTS +/- 10%					12 K DC VOLTS +/- 10%				
			Turbo	HI	MED	LOW	OFF	Turbo	HI	MED	LOW	OFF
INDOOR MOTOR	4	3	28.6	25.6	22.2	20	0	35.7	30.7	25.1	21.2	0
	2	3	5					5				
	1	3	0 TO 5				5	0 TO 5				5
BOARD	PIN NUMBERS TEST FROM		18 K DC VOLTS +/- 10%					24 K DC VOLTS +/- 10%				
			Turbo	HI	MED	LOW	OFF	Turbo	HI	MED	LOW	OFF
INDOOR MOTOR	4	3	32	27.8	24.1	21.2	0	35.7	33.3	29.4	24.2	0
	2	3	5					5				
	1	3	0 TO 5				5	0 TO 5				5

NOTES : ALL WAYS CHECK DC/VOLTAGES AT THE PLUGS DIRECTLY AT BOARDS NOT AT PLUG CONNECTIONS
 PIN NUMBER #3 (Black Wire) IS ALWAYS GROUND
 OUTDOOR BOARD PINS 1 TO 3 ARE COMPRESSOR VOLTAGES

TEMPERATURE / RESISTANCE CHART FOR AMBIENT THERMISTOR

°C	°F	KΩ
OPEN		200
-10	14	62.4
-9	15.8	58.8
-8	17.6	55.4
-7	19.4	52.3
-6	21.2	49.4
-5	23	46.6
-4	24.8	44.1
-3	26.6	41.6
-2	28.4	39.3
-1	30.2	37.2
0	32	35.2
1	33.8	33.3
2	35.6	31.6
3	37.4	29.9
4	39.2	28.3
5	41	26.9
6	42.8	25.5
7	44.6	24.2
8	46.4	22.9
9	48.2	21.8
10	50	20.7
11	51.8	19.7
12	53.6	18.7
13	55.4	17.8
14	57.2	16.9
15	59	16.1

°C	°F	KΩ
16	60.8	15.3
17	62.6	14.6
18	64.4	13.9
19	66.2	13.2
20	68	12.6
21	69.8	12
22	71.6	11.5
23	73.4	10.9
24	75.2	10.4
25	77	10
26	78.8	9.5
27	80.6	9.1
28	82.4	8.7
29	84.2	8.3
30	86	7.9
31	87.8	7.6
32	89.6	7.2
33	91.4	6.9
34	93.2	6.6
35	95	6.3
36	96.8	6.1
37	98.6	5.8
38	100.4	5.6
39	102.2	5.3
40	104	5.1
45	113	4.2
SHORT		0.8

NOTE : ALWAYS CHECK FROM THE PLUG END . AND UNPLUG FROM THE BOARD WHEN TESTING . CHECK AMBIENT TEMP FIRST.

TEMPERATURE / RESISTANCE CHART FOR TUBE THERMISTOR

°C	°F	KΩ
OPEN		100
-25	-13	72.3
-20	-4	52.8
-15	5	39
-10	14	29.1
-5	23	22
0	32	16.8
2	35.6	15.1
4	39.2	13.6
6	42.8	12.3
8	46.4	11.1
10	50	10
12	53.6	9.1
14	57.2	8.3
16	60.8	7.5
18	64.4	6.8
20	68	6.2
22	71.6	5.7
24	75.2	5.2
25	77	5
26	78.8	4.7
27	80.6	4.5
28	82.4	4.3
29	84.2	4.1
30	86	4
31	87.8	3.8
32	89.6	3.6

°C	°F	KΩ
33	91.4	3.5
34	93.2	3.3
35	95	3.2
36	96.8	3.1
37	98.6	2.9
38	100.4	2.8
39	102.2	2.7
40	104	2.6
41	105.8	2.5
42	107.6	2.4
43	109.4	2.3
44	111.2	2.2
45	113	2.1
46	114.8	2.08
47	116.6	2.01
48	118.4	1.93
49	120.2	1.86
50	122	1.79
51	123.8	1.72
52	125.6	1.66
53	127.4	1.6
54	129.2	1.54
55	131	1.48
60	140	1.24
70	158	0.87
80	176	0.63
SHORT		0.4

NOTE: UNPLUG SENSOR FROM BOARD WHEN TESTING .



Discharge Thermistor Values

Discharge Thermistor Resistance Values

°C	°F	kΩ
20	68	244
30	86	164.8
40	104	80.6
60	140	58.3
70	158	42.9
80	176	32.1
90	194	24.4
100	212	18.9
110	230	14.8
120	248	11.7

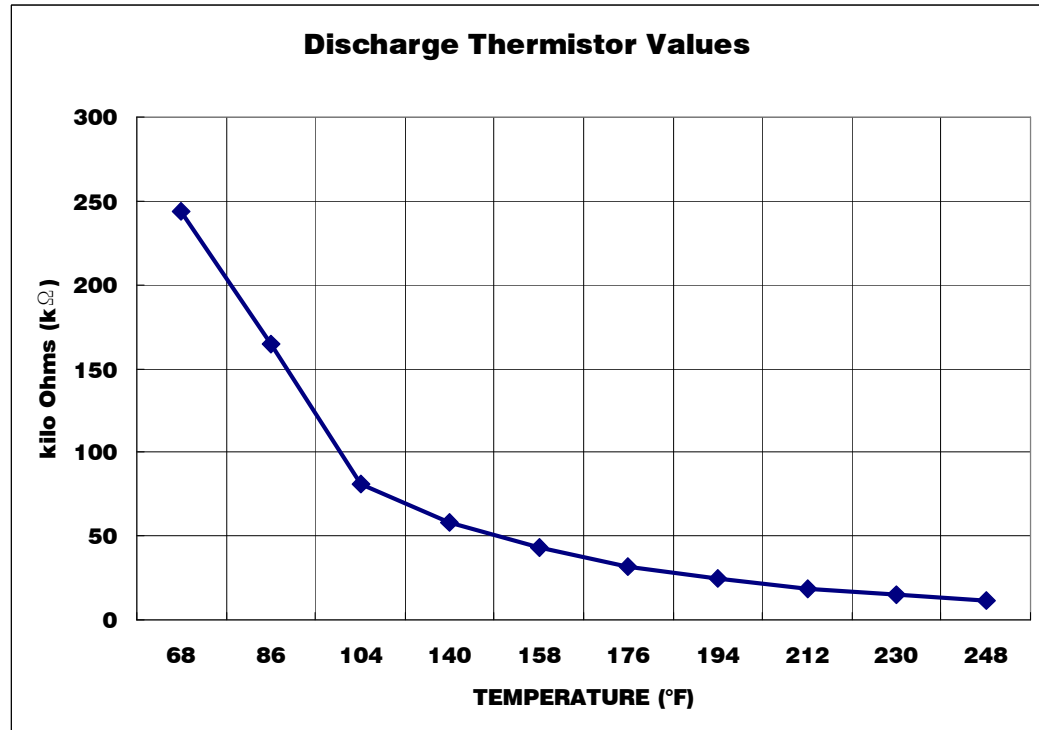

BLDC CONDENSER FAN MOTOR CIRCUIT LSU090/120CE (HE)

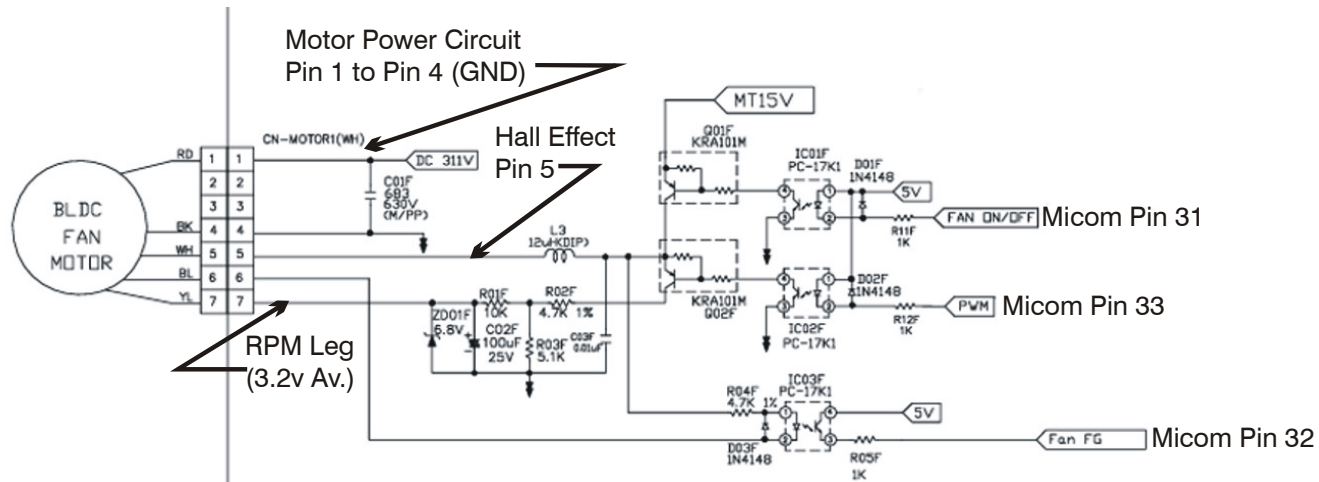

DC Voltage Readings

Pin	Colour	Pin	Colour	ON Voltage	Off Voltage
1	Red	4	Black	310 vdc	310 vdc
5	White	4	Black	15 vdc	0 vdc
7	Yellow	4	Black	1.6 ~ 6.8 vdc	0 vdc

10 SEER Systems

8. Forced Operation

Operation procedures when the remote control can't be used.

Open the front panel upward and move the Slide Switch to the Forced Operation position.

If you want to stop operation, move the Slide Switch to the Auto Restart or the Remote Control position.

In case the power comes on again after power failure on the Forced Operation position, the operating conditions are automatically set as follows:

During Forced Operation, the initial mode continues.

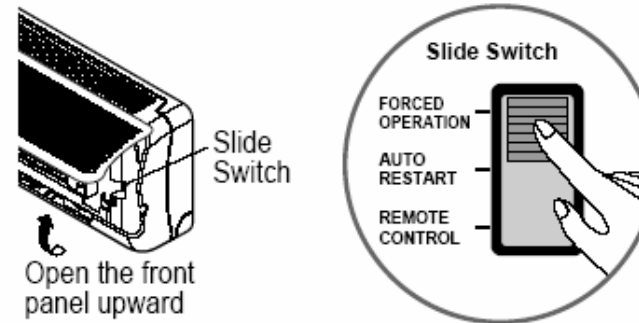

	Cooling Model	Heat pump Model		
		Room Temp. $\geq 24^{\circ}\text{C}(76^{\circ}\text{F})$	$21^{\circ}\text{C}(70^{\circ}\text{F}) \leq \text{Room Temp.} < 24^{\circ}\text{C}(76^{\circ}\text{F})$	Room Temp. $< 21^{\circ}\text{C}(70^{\circ}\text{F})$
Operating mode	Cooling	Cooling	Healthy Dehumidification	Heating
Indoor FAN Speed	High	High	Healthy Dehumidification Rule	High

■ Buzzer Sounding Operation

- When the appliance-operation key is input by the remote control, the short "beep-beep-" sounds.
- When the appliance-pause key is input by the remote control, the long "beep—" sounds.
- When a key is input by the remote control while the slide switch on the main unit of the appliance is on the forced operation position, the error sound "beep-beep-beep-beep-beep-" is made 10 times to indicate that the remote control signal cannot be received.



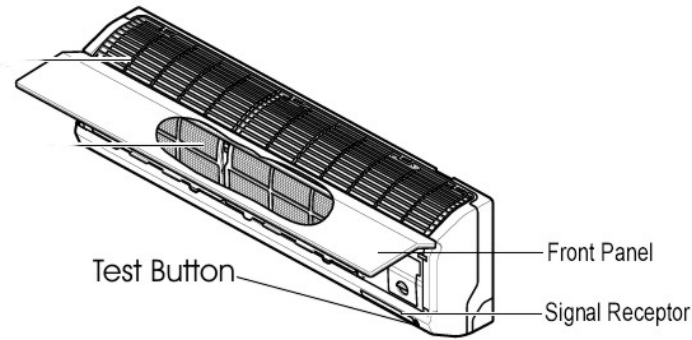



AUTO RESTART – 13 SEER



- All systems are default auto restart from factory.
- Can be inadvertantly toggled off by holding test button.
- To restart:
 1. Turn indoor unit off with remote control.
 2. Hold test button for three seconds – single beep, continue to hold for four more seconds, double beep, power light flashes twice.
 3. Turn unit on with remote control.
- Test system by turning off power, turning on and checking that system has restarted.

Operational Lights

Operation Indication Lamps

-  On/Off : Lights up during the system operation, error code and auto restart setting.
-  Sleep mode : Lights up during sleep mode auto operation.
-  Plasma : The function illustrates its dynamic mode by using a multiple lighting system.
-  Timer : Lights up during timer operation.
-  Defrost mode : Lights up during defrost mode or ***hot start operation** (Heat pump model only)
-  Outdoor unit : Lights up during outdoor unit operation. (Cooling model only)
operation
-  Power Display : Indicates the setting temperature and operation mode.

Operation mode	Cooling, heating, Dehumidification Mode	Auto operation mode						Jet Cool/Heat	Test operation	Auto clean
		Standard	Too hot	Hot	Comfortable	Cold	Too cold			
Shape of display	Setting temperature	A1	-2	-1	0	1	2	Pa	Lo	Co

* **Hot start operation:** Stops the indoor fan in heating operation for minutes to prevent cold air from blowing out from unit.

* In defrost mode unit stops heating operation for few minutes to remove formation of ice on the heat exchanger coils to maintain the efficiency.



Diagnostic Steps 1234 wire

- Determine if #1 (fan) wire is getting 12+ VDC power when test button is pushed.
- If no voltage, jump 1 (fan) & 2 (12VDC) wires. With heavy spark, stop-you have a bad motor!
- With no spark, the fan will run at very low speed. This indicates that the motor is good and the PCB is bad.
- If no voltage, check at outdoor unit at plug-in point of terminal block at outdoor board (2 center terminals).
- Outdoor board powers indoor fan on 36VDC units.
- If no voltage present, outdoor board is faulty. Check fuse on panel. Check 3 & 4 terminals on compressor relay. Line voltage goes to 3 terminal.

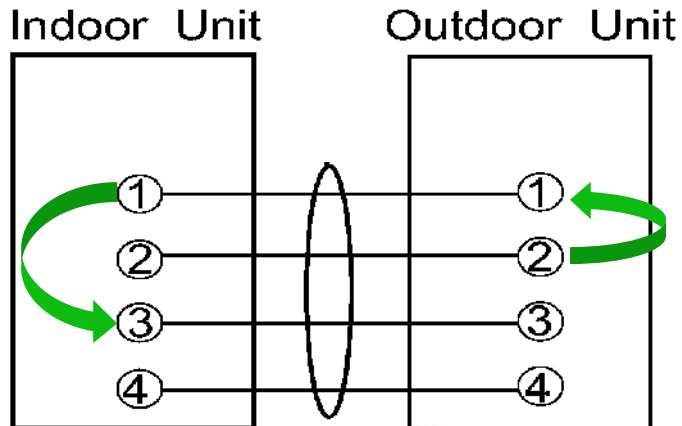

- 1 Fan (20 – 29VDC from PCB by speed chosen)
- 2 12VDC
- 3 Common
- 4 Communication

PIN NUMBERS		9 K		DC VOLTS +/- 10%		
TEST FROM		Turbo	Hi	MED	LOW	OFF
4	3	0 TO 12				
2	3	17				
1	3	28.6	25.6	22.2	20	0